

moray offshore renewables ltd

Developing Wind Energy In The Outer Moray Firth

Environmental Impact Assessment Scoping Report

Modified Transmission Infrastructure:
Offshore substations,
Offshore export cables,
Onshore export cables &
Onshore substations.

April 2014



Version Control			
Revision	Date	Status	Distribution List
A	04-04-2014	Live	MORL
B	08-04-2014	Live	Public

MORL Approval			
Prepared by:	Reviewed by:	Approved by:	Approved by (option):
Peter Moore Title: Consenting Manager Dpt.: Consenting	Sarah Pirie Title: Head of Consenting Dpt.: Consenting	Sarah Pirie Title: Head of Consenting Dpt.: Consenting	N/A

Copyright © 2014 Moray Offshore Renewables Ltd
All pre-existing rights reserved.

Liability

In preparation of this document Moray Offshore Renewables Limited has made reasonable efforts to ensure that the content is accurate, up to date and complete for the purpose for which it was contracted. Moray Offshore Renewables Limited makes no warranty as to the accuracy or completeness of material supplied by the client or their agent.

Other than any liability on Moray Offshore Renewables Limited detailed in the contracts between the parties for this work Moray Offshore Renewables Limited shall have no liability for any loss, damage, injury, claim, expense, cost or other consequence arising as a result of use or reliance upon any information contained in or omitted from this document.

Any persons intending to use this document should satisfy themselves as to its applicability for their intended purpose.

The user of this document has the obligation to employ safe working practices for any activities referred to and to adopt specific practices appropriate to local conditions.

Table of Contents

1	Introduction	11
1.1	The Developers Applying for Consents	12
1.2	The Benefit from the Development	12
1.3	Regulatory and Policy Background.....	13
2	Project Description.....	19
2.1	Objectives of the TI Development.....	19
2.2	TI Assets Location	19
2.2.1	Offshore and Onshore Export Cable Route Selection and Offshore and Onshore Substation Locations	19
2.3	The Proposed Scheme.....	26
2.3.1	Timeline	26
2.3.2	TI Cable Infrastructure.....	28
2.3.3	Offshore TI.....	28
2.3.4	Onshore TI	30
2.4	TI Construction	30
2.4.1	Environmental Management	30
2.4.2	Construction	31
2.5	TI Operation	32
2.5.1	Access to Sites	32
2.5.2	Lighting and Marking.....	32
2.5.3	TI Control and Supervision	32
2.5.4	TI Inspection and Maintenance.....	32
2.6	TI Decommissioning	33
2.7	Ports & Harbours.....	33
3	Cumulative and In-combination Impacts	34
4	Consultation	35
4.1	Relationship and Stakeholder Engagement	35
5	Preliminary Environmental Considerations	35
5.1	Physical Environment.....	35
5.1.1	Data Sources.....	36
5.1.2	Physical Environment (Offshore).....	37
5.1.3	Data Gaps	44
5.1.4	Environmental Impact Scoping.....	44
5.1.5	Underwater Noise	51
5.1.6	Physical Environment (Onshore).....	55
5.1.7	Airborne Noise and Vibration.....	65
5.2	Biological Environment	71
5.2.1	Data Sources.....	71

5.2.2	Benthic Ecology	71
5.2.3	Fish and Shellfish Ecology	80
5.2.4	Marine Mammals	89
5.2.5	Intertidal Benthic Ecology.....	95
5.2.6	Terrestrial Ecology.....	98
5.2.7	Ornithology (Offshore)	109
5.2.8	Designated Sites	114
5.3	Human Environment	114
5.3.1	Data Sources.....	114
5.3.2	Commercial Fisheries	115
5.3.3	Shipping and Navigation.....	119
5.3.4	Ministry of Defence	124
5.3.5	Marine Waste Disposal, Dumping and Dredging	125
5.3.6	Offshore Oil and Gas.....	125
5.3.7	Subsea Cables and Pipelines.....	128
5.3.8	Seascape, Landscape and Visual Receptors	129
5.3.9	Archaeology and Cultural Heritage	137
5.3.10	Socio-Economics, Recreation and Tourism	152
5.3.11	Traffic and Transport	157
5.4	Structure of EIA	162
6	References	164

List of Figures

- Figure 1-1: Round 3 zones
- Figure 1-2: MORL Development Areas and Grid Connection Point
- Figure 2-1: Metoc-Hyder Offshore Export Cable Corridor Study
- Figure 2-2: Offshore export cable route corridor and area in which OSPs will be located
- Figure 2-3: Onshore export cable route corridor and substation search areas
- Figure 2-4: Onshore substation search area (detail)
- Figure 2-5: Project timeline
- Figure 5-1: Bathymetry of development area
- Figure 5-2: Marine geology of Moray Firth
- Figure 5-3: Wind rose data for Moray Firth
- Figure 5-4: Metocean survey equipment deployed
- Figure 5-5: Bedrock geology
- Figure 5-6: Surface water
- Figure 5-7: Superficial geology
- Figure 5-8: Predicted EUNIS seabed habitats
- Figure 5-9: Distribution maps of PMF species taken from Scotland's Marine Atlas (2011)
- Figure 5-10: OSPAR 'Seapen and burrowing megafauna' habitat as mapped by the NBN Gateway in the Moray Firth Sea Area
- Figure 5-11: Nursery grounds within the Moray Firth
- Figure 5-12: Spawning areas within the Moray Firth
- Figure 5-13: Designated sites for diadromous fish species
- Figure 5-14: Designated sites of terrestrial ecological interest
- Figure 5-15: Offshore bird survey overview
- Figure 5-16: Plot of AIS tracks by ship type
- Figure 5-17: Overview of recreational navigation routes
- Figure 5-18: Moray Firth oil and gas licensing blocks and subsea cables and pipelines
- Figure 5-19: Recorded wrecks
- Figure 5-20: Scheduled Monuments records
- Figure 5-21: Scheduled Monuments
- Figure 5-22: Listed Buildings, Gardens and Designated Landscapes, Conservation Areas
- Figure 5-23: Transport routes

List of Tables

- Table 5-1: Details of fish species spawning and nursery activity within the Moray Firth
- Table 5-2: SACs designated for natural fish or freshwater pearl mussel* interest the Moray Firth area.
- Table 5-3: Frequency of marine mammal recordings within the Moray Firth area.
- Table 5-4: Sites Designated for Terrestrial Ecology Within 10 km of MORL's Onshore Cable Route Search Area
- Table 5-5: Potential Effects on Terrestrial Ecology (Excluding Ornithology) as a result of the Proposed OnTI
- Table 5-6: Summary of seasonal seabird distribution and abundance in the OfTI study area.

Acronyms

Acronym	Definition
ADCP	Acoustic Doppler Current Profiler
AIS	Automatic Identification System
BGS	British Geological Society
BOWL	Beatrice Offshore Wind Limited
BTO	British Trust for Ornithology
CAA	Civil Aviation Authority
CEFAS	Centre for Environment, Fisheries and Aquaculture Science
CION	Connections Infrastructure Options Note
COWRIE	Collaboration for Offshore Wind Research in the Environment
CPT	Cone Penetration Test
DECC	Department of Energy and Climate Change
DEFRA	Department for Environment, Food and Rural Affairs
DTI	Department of Trade and Industry
EC	European Commission
EDA	Eastern Development Area
EDP	EDP
EHO	Environment Heath Officer
EIA	Environmental Impact Assessment
EMP	Environmental Management Plan
EPS	European Protected Species
ES	Environmental Statement
FIR	Fisheries Industry Representative
GBS	Gravity Base Substructure
GIS	Geographical Information System
GLA	General Lighthouse Authority
GPS	Geographical Positioning System
HVAC	High Voltage Alternating Current
HVDC	High Voltage Direct Current
ICES	International Council for Exploration of the Sea
IHO	International Hydrographic Organisation
JNAPC	Joint Nautical Archaeology Policy Committee
JNCC	Joint Nature Conservation Committee
LBAP	Local biodiversity Action Plan
LNR	Local Nature Reserve
LSE	Likely Significant Effect
MCA	Maritime and Coastguard Agency
MESH	Marine European Seabed Habitats
MFOWDG	Moray Firth Offshore Wind Dev elopers Group
MoD	Ministry of Defence
MORL	Moray Offshore Renewables Limited
MSS	Marine Scotland Science
NG	National Grid

Acronym	Definition
NPF	National Planning Framework
NRMSDF	National Research and Monitoring Strategy for Diadromous Fish
NTS	Non Technical Summary
NVC	National Vegetation Classification
OFGEM	Office of the Gas and Electricity Markets
OFTI	Offshore transmission infrastructure
OFTO	Offshore Transmission Owner
OGS	Offshore Generating Station
OnTI	Onshore transmission infrastructure
OWF	Offshore Wind Farm
PAD	Protocol for Archaeological Discoveries
PAN	Planning Advice Note
PIA	Personal Injury Accident
PMF	Priority Marine Features
PSD	Particle Size Distribution
R3	Round 3 Offshore Wind Farm Developments
REZ	Renewable Energy Zone
RIGS	Regionally Important Geological/Geomorphological Sites
ROS	Registers of Scotland
SAC	Special Areas of Conservation
SBL	Scottish Biodiversity List
SCADA	Supervisory Control and Data Acquisition
SEA	Strategic Environmental Assessment
SEPA	Scottish Environment Protection Agency
SERL	Sea Energy Renewables Limited
SFF	Scottish Fishermen's Federation
SHE-T	Scottish Hydro Electric Transmission Ltd
SLVIA	Seascape, Landscape and Visual Impact Assessment
SMRU	Sea Mammal Research Unit (University of Aberdeen)
SNH	Scottish Natural Heritage
SPA	Special Protection Areas
SPP	Scottish Planning Policy
SPV	Special Purpose Vehicle
SSC	Suspended Sediment Concentrations
SSE	Scottish and Southern Energy
SSSI	Sites of Special Scientific Interest
STW	Scottish Territorial Waters
SUT	Society for Underwater Technology
TI	Transmission infrastructure
UKBAP	UK Biodiversity Action Plan
UKHO	United Kingdom Hydrographic Office
VMS	Vessel Monitoring System
WDA	Western Development Area

Executive Summary

EDP Renováveis (EDP) and Repsol Nuevas Energias UK (formerly Sea Energy Renewables Limited) formed the joint venture known as Moray Offshore Renewables Limited (MORL) and entered into a Zone Development Agreement with the Crown Estate covering Zone 1 of the nine offshore wind farm zones which were awarded on 8th of January 2010. Zone 1 is located in the outer Moray Firth, within the UK Renewable Energy Zone (REZ) (the Zone).

MORL is developing the Zone in two phases; firstly the Eastern Development Area (EDA) which went to scoping in August 2010 (Offshore Generating Station) (MORL, 2010) and September 2011 (Transmission Infrastructure) (MORL, 2011), for which consent applications were submitted in August 2012. Section 36 consents to construct and operate up to a total of 1,116 MW (a maximum of 372 MW for each of the Telford, Stevenson and MacColl offshore wind farms comprising the EDA) were granted in March 2014. The second phase of the Zone will be the development of the Western Development Area (WDA). It has not yet been determined when the Environmental Impact Assessment process will commence for the WDA.

Through the Connections Infrastructure Options Note (CION) process, MORL has been offered an amended grid connection (replacing the previous connection point at Peterhead) for up to 1,500MW to the existing 275 kV transmission line, owned and operated by Scottish Hydro-Electric Transmission (SHE-T), located south of New Deer in Aberdeenshire (Figure 1-2). This existing 275 kV transmission line is also subject to planned upgrading works to 400 kV. An Offshore Transmission Owner (OFTO) will manage the Transmission Infrastructure (TI) that is required to connect the wind farms to the National Grid. MORL is carrying out the relevant studies to support the required applications for a Town & Country Planning Permission and Marine Licence for the offshore and onshore TI. MORL has decided to undertake the generator build of the TI. The TI will transmit the energy produced from the EDA to the national grid.

This scoping report has two purposes:

1. To gather further information on constraints to siting the TI; and
2. To seek the opinion of statutory and non-statutory consultees on the scope of the Environmental Impact Assessment (EIA) which will be submitted in support of the application for the consents required for the construction and operation of such infrastructure.

This scoping report presents detail regarding the baseline environment in and around the proposed TI development area. This report also identifies potential effects that may arise as a result of this development directly, cumulatively and in combination with other developments. Within this report, studies and surveys are proposed in order to inform the EIA process and preliminary discussion on potential mitigation and monitoring measures is included.

Acknowledgements

Moray Offshore Renewables Limited would like to thank the following people/organisations for their assistance and contributions to the preparations of this scoping report:

- ABP Marine Environment Research Limited
- Anatec Ltd
- Brown & May Marine Limited
- EMU Limited
- Optimised Environments
- RPS

1 Introduction

Moray Offshore Renewables Limited (MORL) entered into a Zone Development Agreement with the Crown Estate to develop Zone 1 of the nine UK Round 3 offshore wind farm zones. Zone 1 is located in the Outer Moray Firth within the UK Renewable Energy Zone (REZ) (the Zone) (Figure 1-1).

Using a zonal constraints analysis MORL has identified two potential development areas (Figure 1-2). The Eastern Development Area (EDA) was considered to have the higher near-term potential for development and was progressed first. Up to 1,116 MW of power capacity will be developed in this area per consents received for Telford, Stevenson and MacColl. The Western Development Area (WDA) will be progressed following on from the EDA. It is anticipated to have a development capacity of up to 500 MW depending on how much capacity is delivered by the EDA. The capacity of the Zone as a whole will be up to a maximum of 1.5 GW.

MORL has been offered an amended connection to the existing 275 kV transmission line, owned and operated by Scottish Hydro-Electric Transmission (SHE-T), located south of New Deer in Aberdeenshire (Figure 1-2) (see section 2.2.1 for further details). This existing 275 kV transmission line is also subject to planned upgrading works by SHE-T to 400 kV. In order to connect into the transmission line, MORL and SHE-T will require to construct substations close to the line. An Offshore Transmission Owner (OFTO) will manage the transmission infrastructure (TI) that is required to connect the wind farm to the National Grid; MORL is carrying out the relevant studies to support the required applications for a Town & Country Planning Permission and Marine Licence for the offshore and onshore TI. MORL has decided to undertake the generator build of the TI and will turn the assets over to the OFTO upon commissioning (see section 1.3). The TI will transmit the energy produced from the EDA to the national grid.

A separate Environmental Statement (ES) detailing the Telford, Stevenson and MacColl offshore wind farms (OGS) (which comprise the EDA) infrastructure proposal (i.e. wind turbines, substructures and interarray cables) was submitted in August 2012 (MORL, 2012), with Section 36 consents awarded in March 2014. MORL has not yet selected any ports or harbours for construction or operation and maintenance work and these are not covered in this document. Since the submission of the MORL ES, the grid connection point has changed from Peterhead to New Deer, and this scoping document supersedes that submitted for the TI in 2011 (Environmental Impact Assessment Scoping Report, 2011). Therefore, this scoping document relates to the works associated with the TI only. The original Offshore TI (OfTI) is currently subject to a Marine Licence application for a DC connection from the EDA to a landfall at Fraserburgh. The Environmental Statement submitted with the Section 36 and Marine Licence applications for the EDA and TI assessed the likely effects of the OfTI to Fraserburgh and as far as possible the effects of the Onshore TI (OnTI) to Peterhead. Following the change in the grid connection point to south of New Deer (see section 2.2.1 for further details) MORL considers that a route from the EDA to a landfall at or near Inverboyndie or Sandend and then onshore to New Deer requires to be progressed and has recently submitted a Marine Licence application in respect of this modified OfTI for an AC connection.

The initial study of the TI covered a wide area, both offshore and onshore. A series of studies were undertaken in order to select a preferred route to connect the offshore substations to the onshore substations (situated as close as possible to the connection point). The iteration process is described in section 2.2.1.

The purposes of this scoping report are to gather further information on possible environmental constraints to the TI and to seek the opinion of the statutory and non-statutory consultees on the proposed scope of the Environmental Impact Assessment (EIA) relating to the MORL TI. A similar exercise was undertaken for the Offshore Generating Station (OGS) (MORL, 2010) and the previous TI to the grid connection point at Peterhead (MORL, 2011) as described above.

Scoping is an early stage of the EIA process and is designed to ensure that the environmental studies undertaken provide all the relevant information required for the assessment. Scoping is the process for determining the content and extent of the matters which should be covered in the environmental information to be submitted to a consenting authority for projects which are subject to EIA. The scoping process is designed for consultees to input into the EIA process for a particular project.

This scoping report provides details of the proposed development area along with baseline environmental information currently available. The potential effects of the development have been identified, along with cumulative and in-combination effects, following which the further assessment required for the EIA has been presented and an outline scope of works provided.

The results of the EIA stage for the MORL OGS and original TI were published in the ES (MORL, 2012). The updated assessments for the modified TI will be submitted in summer 2014.

The final ES will clearly inform stakeholders of how environmental effects have been minimised, identify any mitigation required and set out the residual effects and facilitate informed consent decisions.

1.1 The Developers Applying for Consents

Moray Offshore Renewables Limited (MORL) is a special purpose vehicle (SPV) that was established by EDP Renováveis (EDPR) and SeaEnergy Renewables Ltd. In June 2011, SeaEnergy Renewables Ltd was acquired by Repsol Nuevas Energias UK. Moray Offshore Renewables Ltd is now owned 67 per cent by EDPR UK and 33 per cent by Repsol Nuevas Energias Ltd.

The purpose of MORL is to develop, consent, finance, construct, operate and maintain over the lifetime offshore wind sites within the Zone. MORL intends to apply for the consents required for the TI, but following construction these assets will be transferred to an OFTO for operation and decommissioning (see section 1.3 for information on legislation).

1.2 The Benefit from the Development

MORL's offshore wind farm development will produce electricity from a renewable energy source. This renewable energy will be transferred to the National Grid through the TI. The need for the development is explained through a series of International and National Policies, as summarised below.

The introduction of the Climate Change Act (2008) committed the UK to a legally binding target of at least 34% reduction in greenhouse gas emissions from 1990 levels by 2020 and at least an 80% reduction by 2050. The Climate Change (Scotland) Act (2009) committed Scotland to cut emissions by 42% by 2020 and 80% by 2050. As part of the Renewable Energy Strategy for the UK, the UK Government has set national targets for more than 30% of electricity consumption to be generated from renewables by 2020 (DECC, 2009a). Subsequently, the Scottish Government has set a target of "generating the equivalent of 100% of Scotland's own electricity demand from renewable resources by 2020" with the First Minister stating that "Offshore wind will play a key role in achieving our ambitions" (Scottish Government, 2011).

Wind energy is a means of generating electricity without producing significant airborne or waterborne toxic emissions, and is not dependant on finite reserves of fossil fuels. It is ultimately a sustainable and proven technology, a fact that is recognised by the UK Government through its support for wind energy development. To date there have been three UK wide rounds and one Scottish round of offshore wind development, administered by The Crown Estate. As of December 2013, the UK had an installed offshore wind generation capacity of 3,653 MW, with a further 1,401 MW under construction and a further 2,746 MW consented under Round 1 and 2 releases. In March 2014, the Scottish Government granted consent for up to 1,866 MW of offshore wind generation capacity in the Moray Firth (i.e. consents for the Telford, Stevenson and MacColl offshore wind farms and a further Scottish Territorial Waters site (i.e. Beatrice Offshore wind farm)).

1.3 Regulatory and Policy Background

Under the provisions of the Energy Act 2004, operation of an offshore transmission system became a licensable activity. In keeping with EC unbundling legislation, it is not permissible for a developer to hold both a generation and transmission licence for more than 18 months (except under very exceptional circumstances). The consequence of this is that the owners and operators of the offshore wind farms cannot retain operational control of any OFTO assets. It is, however, permissible for them to construct and install OFTO assets prior to them becoming operational. Exercising such a choice is deemed as the generator build option.

At the time when the Section 36 consents for the OGS were applied for there was no single consent which provided permission to construct infrastructure which spans offshore and onshore terrain. Recent changes to legislation which allow applicants for Section 36 consents to apply for “deemed planning” permission as part of the Section 36 do not apply retrospectively and are therefore not applicable to the MORL TI. The construction of onshore (i.e. above mean low water springs) ancillary infrastructure requires consent under The Town and Country Planning (Scotland) Act 1997. This consent will be applied for as a separate Town & Country Planning application to be submitted to the relevant Local Planning Authority.

THE TOWN AND COUNTRY PLANNING (SCOTLAND) ACT 1997

An application under the Town & Country Planning (Scotland) Act 1997, as amended, will be submitted to Aberdeenshire Council, as the local planning authority, for the OnTI works.

There are a number of relevant national planning policy and guidance documents in Scotland consisting of National Planning Framework (NPF), Scottish Planning Policy (SPP), Planning Advice Notes (PANs) and Planning Circulars. These policies are further supported by Statutory Development Plans which comprise of Strategic Development Plans and Local Development Plans.

The Aberdeen City and Shire Structure Plan (Aberdeen City Council & Aberdeenshire Council, approved 2009) and the Aberdeenshire Local Plan (Aberdeenshire Council, adopted 2006) will also apply to this development and the entire proposed onshore works will lie within Aberdeenshire Council (Northeast area). Section 25 of the 1997 Act provides that determinations must be made in accordance with these plans unless material considerations indicate otherwise. Both plans support the principle of renewable energy developments provided they comply with the provisions of local planning policy.

REQUIREMENT FOR AN ENVIRONMENTAL IMPACT ASSESSMENT (EIA)

In terms of EC Directive 85/337/EEC on the assessment of the effects of certain public and private projects on the environment as amended by Directive 97/11/EC, both of which are now codified in Directive 2011/92/EU (the EIA Directive) certain developments must to be subject to EIA. The purpose of the Directive is to ensure that, in considering whether to grant consents for developments that are likely to have significant environmental effects, the consenting authorities have all the necessary environmental information on which to base their decision.

Under The Town and Country Planning (Environmental Impact Assessment) (Scotland) Regulations 2011, the onshore substation is classified as a Schedule 2 development (given its development area) and therefore requires an EIA. MORL has elected to include for the purposes of scoping of the TI the export cables (onshore and offshore) and offshore substations.

There is a requirement to consider cumulative and in-combination effects as part of the EIA process. Projects to be included in such an assessment must include existing projects and those currently in the planning system. Projects to be included in such an assessment must include not only other potential renewable energy projects, but also other types of project taking place in the marine/coastal and terrestrial environment.

MARINE (SCOTLAND) ACT 2010 AND THE MARINE AND COASTAL ACCESS ACT 2009

A Marine Licence will be sought by MORL for the development of the offshore substations and offshore export cables in terms of Part 4 of the Marine and Coastal Access Act 2009 (to the extent the TI is located in the

Scottish offshore region i.e. 12 to 200 nm) and Part 4 of the Marine (Scotland) Act 2010 (in respect of those elements of the OfTI located within Scottish inshore region i.e between 0-12 nm).

THE CROWN ESTATE ACT 1961 AND THE ENERGY ACT 2004

The Crown Estate Commissioners, are the owner of the foreshore and the seabed below the territorial seas of the UK under the Crown Estate Act 1961 and are the party entitled to exercise the right to exploit areas outside the territorial seas for the production of energy from water or winds within the areas designated under the Renewable Energy Zone (Designation of Area) Order 2004. The Commissioners require a lease of the seabed and foreshore within the territorial seas or a lease of rights of the areas outside the territorial seas to be granted for developments on the marine estate, including cable laying and construction of the offshore substation. The Agreements for Lease provide for the grant of a Lease after the Key Project Consents are obtained. This is a statutory consent granted in the form of a lease.

HABITATS DIRECTIVE (DIRECTIVE 92/43/ECC) AND WILD BIRDS DIRECTIVE (DIRECTIVE 2009/147/EC: REQUIREMENT FOR APPROPRIATE ASSESSMENT

The Habitats Directive provides for the conservation of natural habitats and of wild flora and fauna including in offshore areas. The Wild Birds Directive applies to the conservation of all species of naturally occurring wild birds including in offshore areas. Both Directives have been transposed into Scottish Law by the Conservation (Natural Habitats &c) Regulations 1994, as amended (Habitat Regulations) and in the offshore marine area by the Offshore Marine Conservation (Natural Habitats &c) Regulations 2007, as amended (Offshore Marine Regulations). They require a Habitats Regulation Assessment (HRA) to be conducted by the 'competent authority' before a plan or project that is likely to have a significant effect on designated or candidate Special Protection Areas (SPA) or Special Areas of Conservation (SAC), can be given consent, permission or other authorisation. The UK SACs and SPAs form the Natura 2000 network, which is at the core of the Habitats Directive.

EUROPEAN PROTECTED SPECIES

Annex IV of the Habitats Directive lists certain species of European Community interest which are in need of strict protection. Any of these species whose natural range includes any area in Great Britain are called 'European Protected Species'. Their places of shelter are fully protected and it is an offence to damage, destroy or obstruct access to or otherwise deny the animal use of a breeding or resting site, whether deliberately or not. It is also an offence to disturb in a manner that is, or in circumstances which are likely to significantly affect the local distribution or abundance of the species, disturb in a manner or circumstances which are likely to impair its ability to survive, breed or reproduce, or rear or otherwise care for its young.

Licences may be given authorising activities involving European Protected Species of plants or animals which would otherwise be illegal under the Regulations. The licences are granted by Scottish Natural Heritage (SNH) or the Scottish Government depending on the reason for the licence application.

THE WILDLIFE AND COUNTRYSIDE ACT 1981 AND THE NATURE CONSERVATION (SCOTLAND) ACT 2004

The Wildlife and Countryside Act 1981 (as amended by the Countryside Rights of Way Act 2004 (the 1981 Act) is designed to protect wildlife in the UK. The Nature Conservation (Scotland) Act 2004 (the 2004 Act) is the principal law by virtue of which wildlife is protected in Scotland. Provisions of both Acts tend to overlap as the 1981 Act also offers wildlife protection in Scotland. All species of wild birds are afforded protection under the acts. Furthermore, Chapter 1 of Part 2, and Schedules 1 and 5, of the 2004 Act repeals the SSSI provisions of the 1981 Act, providing for the enhanced protection and management of SSSIs, requiring the preparation of site management statements and amending notification procedures. The provisions place a duty on public bodies for the further conservation and enhancement of SSSIs, providing a new offence whereby third parties can be convicted for damaging SSSIs and enable the making of byelaws for the protection of SSSIs.

PROTECTION OF BADGERS ACT 1992

The Protection of Badgers Act 1992, as amended by the Nature Conservation (Scotland) Act 2004 and the Wildlife and Natural Environment (Scotland) Act 2011, makes it an offence to recklessly take, injure or kill a badger, or destroy or cause disturbance to its sett. Any sett within an active badger territory is afforded legal protection, whether it shows signs of recent use or not. In addition, badgers are afforded protection from cruel ill-treatment, which includes preventing a badger access to its sett, as well as causing the loss of significant foraging resources within a badger territory.

WILDLIFE AND NATURAL ENVIRONMENT (SCOTLAND) ACT 2011

Following the introduction of the Wildlife and Natural Environment (Scotland) Act 2011 (WANE), Scottish Ministers have delegated the majority of their species licensing powers to SNH. Scottish Ministers delegated all existing licensing powers under the Wildlife and Countryside Act 1981, Protection of Badgers Act 1992 and Habitats Regulations to SNH, though exceptions include certain areas of licensing in respect to cetaceans (whales, dolphins and porpoises). WANE modernises outdated legislation and corrects anomalies and weaknesses in current legislation. It is focused on countryside management (e.g. modernising game law and strengthening protection of badgers), but also changes the licensing system for protected species, regulates the control of invasive non-native species, and makes operational changes to the management of SSSIs.

SALMON AND FRESHWATER FISHERIES (CONSOLIDATION) (SCOTLAND) ACT 2003

Consideration is required to be given to the Salmon and Freshwater Fisheries (Consolidation) (Scotland) Act 2003. The Act offers protection to salmon and sea trout.

PROTECTION OF SEALS UNDER THE MARINE (SCOTLAND) ACT 2010

On the 1st February 2011, it became an offence to kill, injure or take a seal at any time of year, except to alleviate suffering or where a licence has been issued to do so by Marine Scotland under Part 6 of the Marine (Scotland) Act 2010. The method of killing or taking seals is detailed in the licence issued and regular reporting will be required.

MARINE STRATEGY FRAMEWORK DIRECTIVE (DIRECTIVE 2008/56/EC)

The Marine Strategy Framework Directive 2008/56/EC (MSFD) aims to achieve Good Environmental Status in Europe's seas by 2020. Good Environmental Status involves protecting the marine environment, preventing its deterioration and restoring it where practical, while using marine resources sustainably. This fits well with the UK's vision of 'clean, healthy, safe, productive and biologically diverse oceans and seas'. The MSFD sets out 11 high level Descriptors of Good Environmental Status which cover all the key aspects of the marine ecosystem and all the main human pressures on them.

It is inextricably linked to the Water Framework Directive 2000 / 60 / EC (WFD). WFD relates to improving and protecting the chemical and biological status of surface waters throughout a river basin catchment from rivers, lakes and groundwater through to estuaries (transitional) and coastal waters to one nautical mile out to sea (three nautical miles in Scotland) and overlaps with MSFD in coastal waters.

WATER ENVIRONMENT AND WATER SERVICES (SCOTLAND) ACT 2003

Under the Water Environment and Water Services (Scotland) Act 2003 river basin management plans must be produced and implemented. River basins include all estuaries and coastal waters extending to 3 nm seaward from territorial waters. Any proposed development within 3 nm must have regard to the requirements of the WFD to ensure that all surface waters achieve Good Ecological Status and that there is no deterioration in status.

LAND REFORM (SCOTLAND) ACT 2003

The Land Reform (Scotland) Act 2003 established statutory rights of responsible access to land and inland water for outdoor recreation, crossing land and some educational and commercial purposes (also known as Scottish access rights).

OTHER CONSENTS REQUIRED

The generating stations have already been consented under Section 36 of the Electricity Act 1989. Marine Licences for the Telford, Stevenson and MacColl wind farms have been applied for and are pending determination

© Crown Copyright [2014]. This document is the property of contractors and sub-contractors and shall not be reproduced nor transmitted without prior written approval.
Moray Offshore Renewables Ltd © 2014.

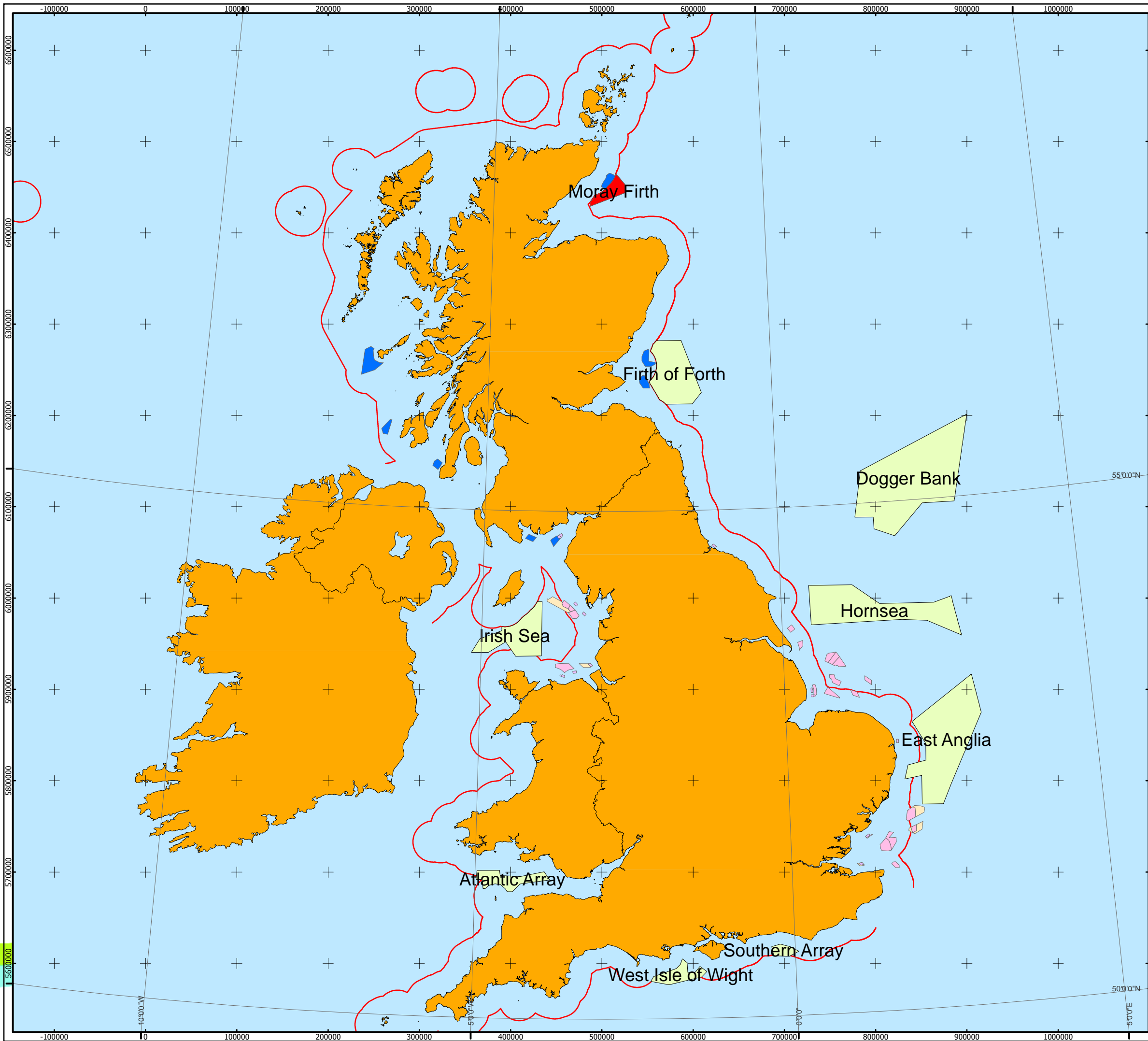

Moray Offshore Renewables Ltd

KEY

- Moray Offshore Wind Farm (R3)
- Round 3 Zones
- Round 2 Zones
- Round 1 Zones
- Scottish Territorial Waters
- Extensions
- 12nm Territorial Sea Limit

Horizontal Scale: 1:4,000,000 A3 Chart
0 100,000 200,000 Meters

Geodetic Parameters: WGS84 UTM Zone 30N

Produced: RH
Reviewed: PM
Approved: SP

Date: 31/03/2014 Revision: A
REF: 8460001-PSO0010-MOR-MAP-029

Fig 1-1 Round 3 Zones

Moray Offshore
Renewables Ltd

Contains Ordnance Survey data © Crown Copyright and database right [2014].
 © SeaZone Solutions Limited, 2005, [012009.001, 022011.009]. This product includes mapping data licensed from Ordnance Survey (Great Britain) with the permission of HMSO. © Crown Copyright, 2006. All rights reserved.
 Moray Offshore Renewables Ltd © 2014. This document is the property of contractors and sub-contractors and shall not be reproduced nor transmitted without prior written approval.

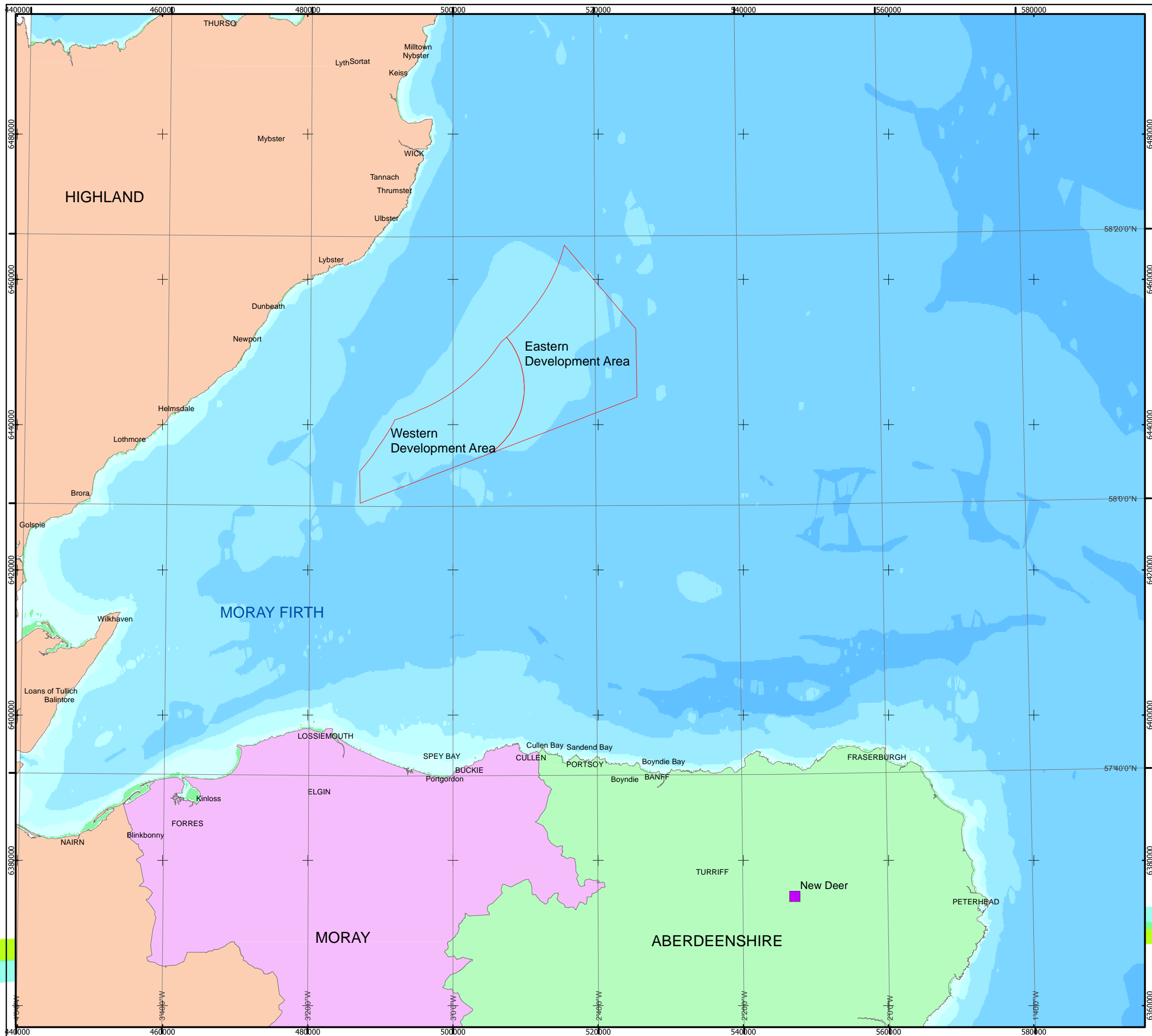

Moray Offshore Renewables Ltd

KEY

■ Grid Connection Interface Point

□ The Zone

Bathymetry (m)

- >10000
- ≤10000
- ≤5000
- ≤1000
- ≤500
- ≤100
- ≤50
- ≤20
- ≤10
- ≥0

Horizontal Scale: 1:500,000

A3 Chart

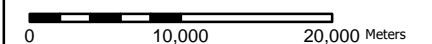

Geodetic Parameters: WGS84 UTM Zone 30N

Produced: RH
 Reviewed: PM
 Approved: SP

Date: 07/04/2014 Revision: B

REF: 8460001-PSO0010-MOR-MAP-030

Fig 1-2 MORL Development Areas & Grid Connection Point

Moray Offshore Renewables Ltd

2 Project Description

This section provides a high level description of the proposals for the TI required to connect the wind farms that will be developed by MORL to the pre-existing onshore National Electricity Transmission System (NETS). It should be noted that the TI design process is at an early stage, and therefore many aspects of the design are yet to be finalised. The information contained in this report reflects the design envelope at the time of writing. There are three main elements to the TI, these being the offshore substation platform(s) (OSP) structures accommodating those assets necessary for the collection and conversion of power from the individual wind turbine generators (WTGs), the offshore to onshore cables for the bulk transfer of power and the onshore assets (i.e. onshore cables and substations) necessary to facilitate the final connection to the pre-existing assets of the National Electricity Transmission System (NETS).

2.1 Objectives of the TI Development

The primary objective of the TI development is to collect the energy generated by the offshore wind turbine generators (WTGs) and provide a bulk transfer conduit to transmit the energy to the national grid interface point located onshore. The MORL projects will offset the emission of greenhouse gases, in line with the UK's commitments under the Kyoto Protocol (please see MORL's Environmental Statement (ES) for the Telford, Stevenson and MacColl wind farms for details on renewable energy targets and policies).

The provision of the TI allied to the installation of WTGs will make a significant contribution towards the reduction of harmful greenhouse gas emissions that could otherwise be generated from fossil fuel electricity generation.

2.2 TI Assets Location

The TI within the Telford, Stevenson and MacColl offshore wind farms will comprise up to two HVAC OSPs and associated HVAC cabling. The OSPs will be located within the Eastern Development Area (EDA), the export cable joins the OSPs to the NETS south of New Deer via the proposed onshore substations.

2.2.1 Offshore and Onshore Export Cable Route Selection and Offshore and Onshore Substation Locations

The proposals for the original TI both offshore and onshore are outlined in the ES which accompanied the Section 36 and Marine Licence (ML) applications the 'Project' (defined as up to three wind farm sites (Telford, Stevenson and MacColl) within the EDA, together with the offshore and onshore TI). At the time these applications were made, Scottish Hydro Electric Transmission (SHE-T) had offered MORL a grid connection point at Peterhead power station using Direct Current (DC) technology; consequently MORL had undertaken work to develop onshore and offshore proposals on this basis, including a landing-point at Fraserburgh beach, an underground cable route to Peterhead, and a substation at Peterhead.

The regulatory environment demands that SHE-T and National Grid (NG) work together with the transmission owner for the developer's assets (in the case of generator build, the generator will take on this role) to take account of the changing system background for the grid in order to maximise its efficient use. This is done through the CION (Connections Infrastructure Options Note) process. Along with other projects, MORL was considered by NG and SHE-T under the CION process in 2013. Subsequently, SHE-T and NG determined that consumers would benefit from a more economic and efficient connection if MORL was connected to the grid where it passes New Deer (where the shorter length of the TI means that an AC, rather than the more expensive DC, connection can be implemented). Thus SHE-T and NG replaced MORL's connection at Peterhead, with one at New Deer (still within Aberdeenshire Council's area). This requires alternative offshore

and onshore works proposals to be developed. The grid connection near New Deer is approximately 75 km southeast of MORL's EDA (Figure 1-2).

MORL has previously commissioned an Export Cable Feasibility Study (Metoc-Hyder, 2011). This study was primarily desk-based (with site visits to the identified landfall points) which aimed at identifying options and assessing feasibility for 2 km route corridors for export cable (onshore and offshore), landfall points and onshore substation locations taking into account the likely environmental issues and engineering and health and safety constraints. The onshore route also incorporated the Holford Rules for overhead lines, with adaptations for underground lines. The study identified 13 offshore cable routes, 11 potential landfall points, and three primary onshore route corridors which diverged to connect with eight of the potential landfall points (the onshore corridor width for the study was 2 km, which meant all 11 landfall points were covered in the onshore corridor study) (Figure 2-1). These routes were ranked on environmental, engineering and economic issues and narrowed down in the assessment process to 8 landfall points and the route corridors were reduced down to a width of 500 m. These eight landfall points and associated onshore and offshore routes were then taken forward to a concept engineering study by JP Kenny (JP Kenny, 2011). This study assumed an onshore grid connection point at Peterhead. Following the findings from the CION process to alter the connection point to New Deer, MORL commissioned PCS to undertake an assessment of potential grid connection points in the New Deer area (PCS, 2013). This study identified seven general locations, in close vicinity to the existing overhead 275 kV line, that were suitable for MORL's requirements. MORL then commissioned a feasibility study to assess these locations, and the proposed cable routes, from an environmental and planning perspective (RPS, 2013).

This iteration process for landfall point selection, offshore and onshore cable routes and onshore substation is described in the following sections. The selection criteria used include route length, engineering and health and safety constraints, physical and third party constraints and environmental and consenting constraints.

LANDFALL SELECTION

A stage 1 concept engineering study for the export cable route was undertaken to develop, evaluate, compare and rank cable route options from the offshore substations to the onshore connection point (Metoc-Hyder, 2011). The eight landfall points identified in the study were assessed against engineering, physical / third party constraints and environmental and seabed use constraints (see Technical Appendix 2.1 B of the MORL ES). GIS data and associated constraint mapping were generated to conduct a detailed desktop route selection process. From this study it was concluded that four landfall points be taken forward to the next stage of Concept Engineering - Sandend, Inverboyndie, Fraserburgh Beach and Rattray North and South. It became clear that the other route options being considered had various inadequacies that made the concept untenable.

Concept engineering stage 2 looked at the remaining four routes developing indicative cost estimates and comparing each option against relative complexity, risk and cost. Four out of the initial 11 landfall points identified within the Export Cable Feasibility Study were taken to the next stage of the study: Inverboyndie, Sandend, Fraserburgh and Rattray (for further information see Technical Appendices 2.1 A and B of the MORL ES).

Following confirmation of the grid connection point at New Deer, the two preferred landfall points were selected, shown below. These were selected following the results from the Metoc-Hyder, JP Kenny, PCS and RPS reports and using the criteria described above (Figure 2-1):

- Inverboyndie; and
- Sandend.

The sites further to the east of these landfall points were discounted for constructability issues, primarily in relation to the offshore route, which would have to route around to the east of the Southern Trench and would therefore be in excess of 100 km.

Inverboyndie and Sandend are considered the preferred options with minimal impact on the environment and the shortest overall cable route.

OFFSHORE EXPORT CABLE ROUTE

The concept engineering study concluded both landfall points would meet engineering and construction requirements (JP Kenny, 2011 – see Technical Appendix 2.1 B of the MORL ES). Figure 2-2 shows the offshore export cable route corridor.

ONSHORE EXPORT CABLE ROUTE

The onshore routes associated with the two landfall points identified during the Export Cable Feasibility Study (Metoc-Hyder, 2011) were also deemed to satisfy all routing constraints and to meet engineering and health and safety operational and construction requirements during the concept engineering study (JPKenny, 2011), technical grid connection study (PCS, 2013) and environmental and planning study (RPS, 2013). Figure 2-3 shows the onshore export cable route corridor.

OFFSHORE SUBSTATION LOCATIONS

The design of the OfTI electrical infrastructure is at an early stage. In order to provide the required level of detail on the project that will be required for the modified assessments, options are currently being considered by MORL for all of the key components, including finalising the number (up to two) and location of OSPs.

Figure 2-2 identifies the area (the EDA) within which the OSPs (up to two HVAC offshore platforms) will be located.

ONSHORE SUBSTATION LOCATIONS

MORL will require one AC substation, covering an area of up to approximately 270 x 190 m at the connection point near New Deer (PCS, 2013). The current search area for possible installation of the onshore substations is shown in Figure 2-4. MORL is currently undertaking land negotiations and environmental surveys, and the exact substation locations are still to be defined. In order to allow the connection of MORL, SHE-T also require to construct a new substation, connecting to the NETS by the existing 275 kV overhead line at New Deer. This substation will be in addition to the MORL substation and will be up to 333 x 218 m. The onshore substation sites identified by MORL for investigation allows for the co-location of the MORL and SHE-T substations (i.e. the MORL and the SHE-T substations of 270 x 190 m and 333 x 218 m respectively).

CURRENTLY SELECTED ONSHORE EXPORT CABLE ROUTES AND ONSHORE SUBSTATION LOCATION

As described above, two main onshore routes are still being considered (onshore and offshore) based on two preferred landfall points (Figure 2-4). It is MORL's intention to define the exact cable route and location of the onshore substations following completion of the geophysical surveys, environmental surveys and landowner negotiations where applicable.

Contains Ordnance Survey data © Crown Copyright and database right [2014].
 © SeaZone Solutions Limited, 2005, [012009.001, 022011.009]. This product includes mapping data licensed from Ordnance Survey (Great Britain) with the permission of HMSO. © Crown Copyright, 2006. All rights reserved.
 Moray Offshore Renewables Ltd © 2014. This document is the property of contractors and sub-contractors and shall not be reproduced nor transmitted without prior written approval.

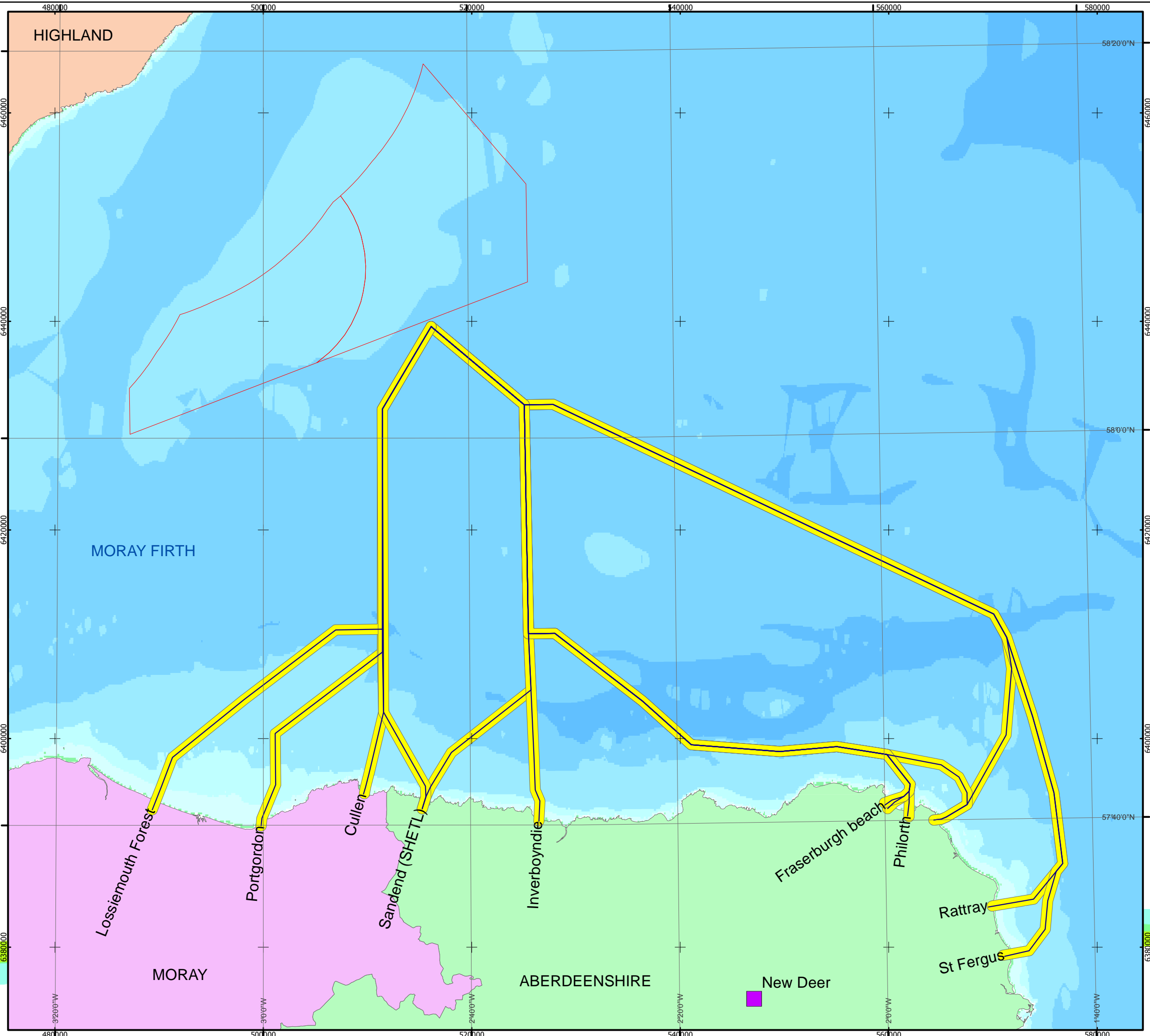

Moray Offshore Renewables Ltd

- KEY**
- Grid Connection Interface Point
 - METOC-Hyder Offshore Cable Route Initial Options
 - METOC-Hyder Offshore Cable Route Corridor
 - The Zone

- Bathymetry (m)**
- >10000
 - <=10000
 - <=5000
 - <=1000
 - <=500
 - <=100
 - <=50
 - <=20
 - <=10
 - >=0

Horizontal Scale: 1:350,000 A3 Chart

Geodetic Parameters: WGS84 UTM Zone 30N	
Produced: RH	
Reviewed: PM	
Approved: SP	
Date: 07/04/2014	Revision: B
REF: 8460001-PSO0010-MOR-MAP-031	

Fig 2-1 Metoc-Hyder Offshore Export Cable Corridor Study

Moray Offshore Renewables Ltd

SeaZone Solutions Limited, 2005 [012009.001]. © British Crown Copyright, 2005. All Rights Reserved. This document is the property of contractors and sub-contractors and shall not be reproduced nor transmitted without prior written approval. Moray Offshore Renewables Ltd © 2014.

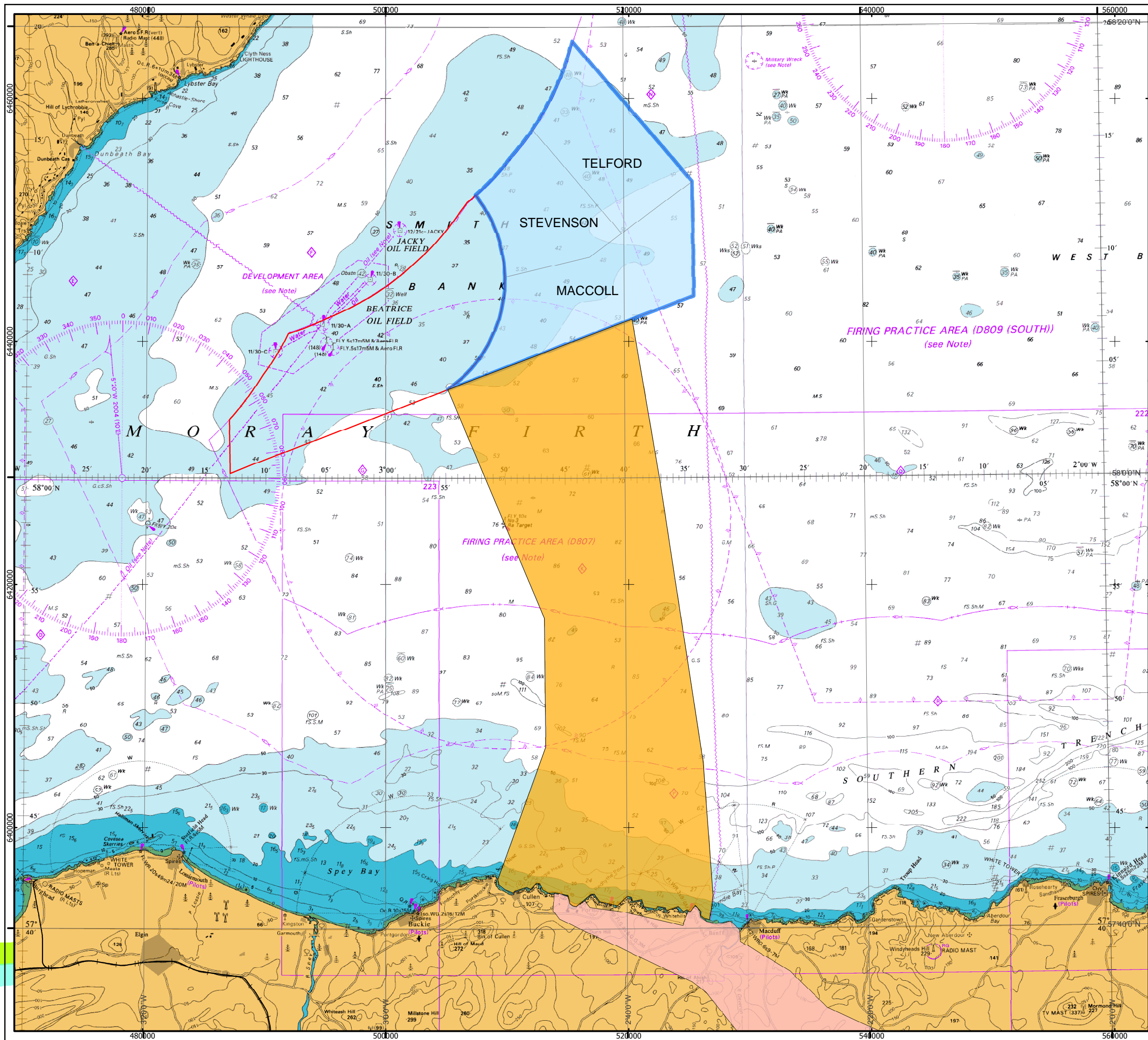

Moray Offshore Renewables Ltd

- KEY**
- Offshore Cable Corridor
 - Onshore Cable Corridor Search Area
 - Area within which OSPs will be located (EDA)
 - The Zone

Horizontal Scale: 1:300,000 A3 Chart

Geodetic Parameters: WGS84 UTM Zone 30N

Produced: RH
 Reviewed: PM
 Approved: SP

Date: 07/04/2014 Revision: B
 REF: 8460001-PSO0010-MOR-MAP-032

Fig 2-2 Offshore Export Cable Route Corridor and area within which OSPs will be located.

Moray Offshore Renewables Ltd

© Crown copyright and database rights [2013] Ordnance Survey [License Numbers: 1350462, 1326001, 1065958].
Moray Offshore Renewables Ltd © 2014. This document is the property of contractors and sub-contractors and shall not be reproduced nor transmitted without prior written approval.

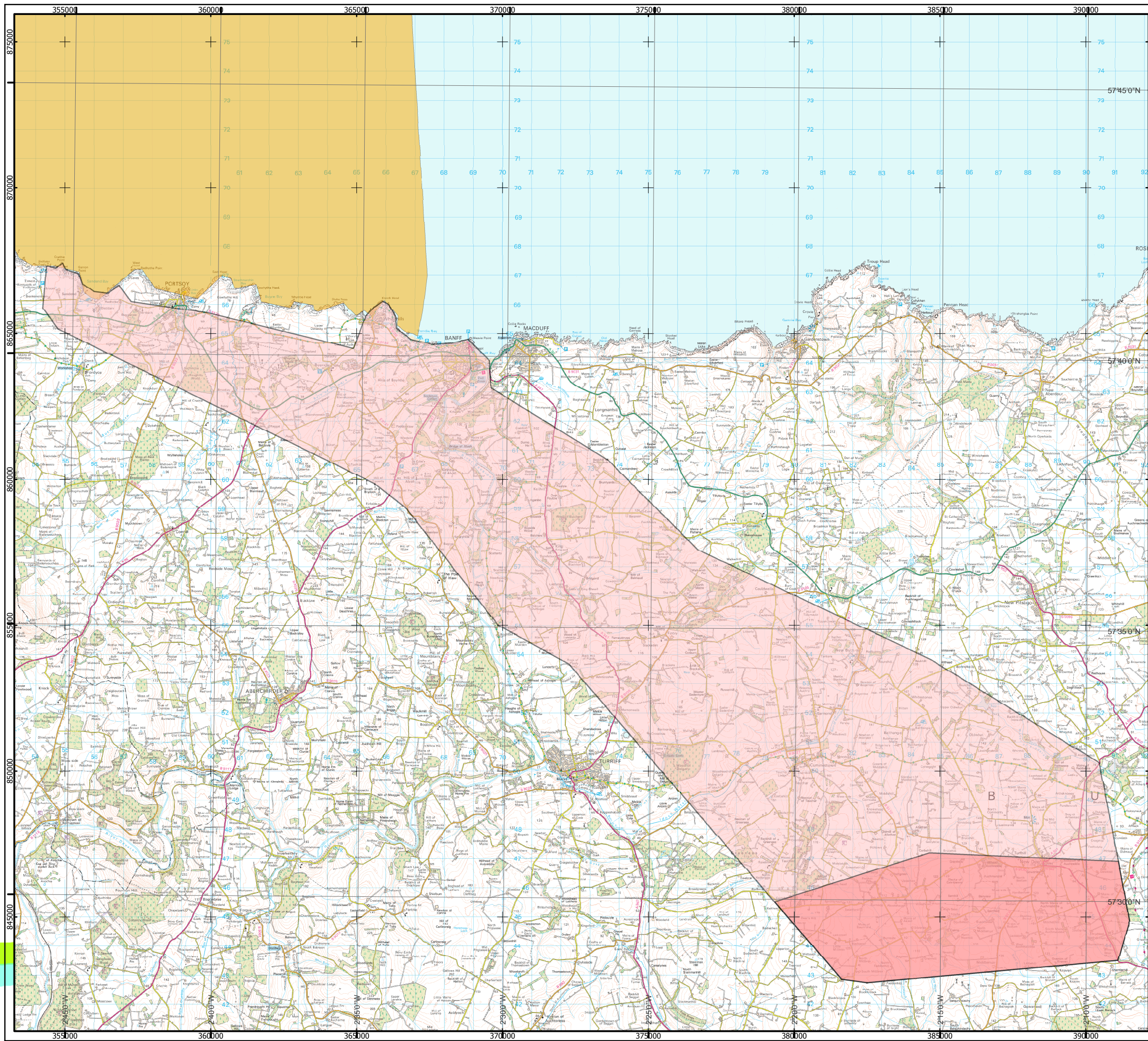

Moray Offshore Renewables Ltd

KEY

- Onshore Cable Corridor Search Area
- Onshore Substation Search Area
- Offshore Cable Corridor

Horizontal Scale: 1:125,000 A3 Chart
0 2,500 5,000 Meters

Geodetic Parameters: British National Grid

Produced: RH
Reviewed: PM
Approved: SP

Date: 07/04/2014 Revision: B
REF: 8460001-PSO0010-MOR-MAP-033

Fig 2-3 Onshore Export Cable Route Corridor and Substation Search Areas

Moray Offshore Renewables Ltd

© Crown copyright and database rights [2013] Ordnance Survey [License Numbers:1350462, 1326001, 1065958].
Moray Offshore Renewables Ltd © 2014. This document is the property of contractors and sub-contractors and shall not be reproduced nor transmitted without prior written approval.

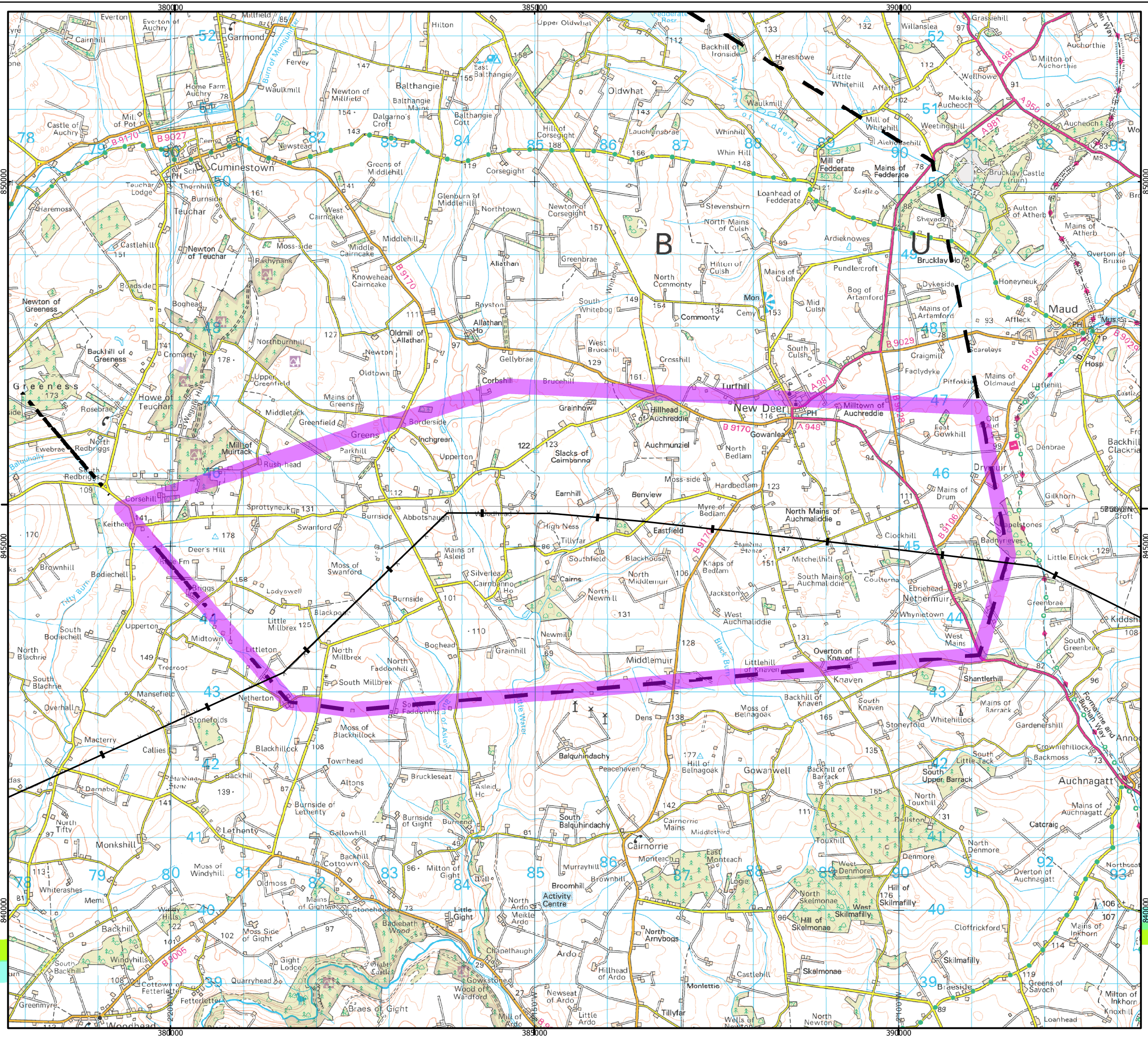

Moray Offshore Renewables Ltd

KEY

- Overhead Electric Line
- ▭ Onshore Substation Search Area
- - - Onshore Cable Corridor Search Area

Horizontal Scale: 1:50,000 A3 Chart
0 1,000 2,000 Meters

Geodetic Parameters: British National Grid

Produced: RH
Reviewed: PM
Approved: SP

Date: 31/03/2014 Revision: A
REF: 8460001-PSO0010-MOR-MAP-034

Fig 2-4 Onshore Substation Search Area (detail)

Moray Offshore Renewables Ltd

2.3 The Proposed Scheme

2.3.1 Timeline

An indicative timeline for development of the TI works is provided in Figure 2-5. There will be different organisations responsible for issuing the consents (see Section 1.3, Regulatory and Policy Background, for detailed consenting information), however for the purposes of this document it is assumed that there will be similar consenting timescales for the onshore and the offshore aspects of the TI. Therefore, the award of full consents would be anticipated later in 2014. The installation process of TI assets will begin in 2016 and the construction is anticipated for completion by 2021 (assuming a phased installation process along with the construction of the wind farms).

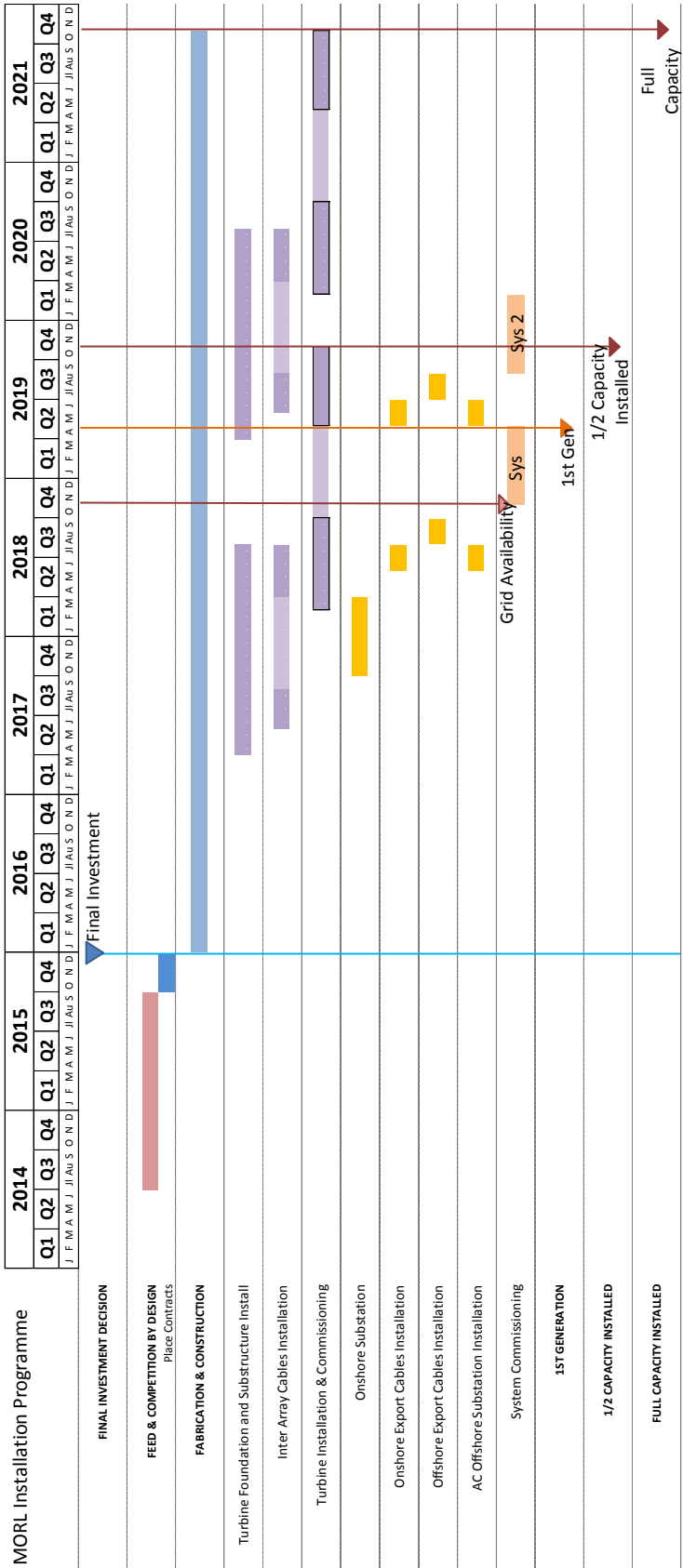

Figure 2-5: Project Timeline

2.3.2 TI Cable Infrastructure

The modified TI cable infrastructure will consist of both onshore and offshore cable systems. The constituent parts of this overall system can be summarised as follows:

- Offshore transmission system: up to four triplecore submarine HVAC export cables in up to four separate trenches between the offshore platforms and the shore, which are used to transmit the energy generated by the WTGs to the shore. The cables may include embedded fibre optic data and communication cable cores.
- Subsea cabling specification (AC, voltage levels 150kV/ 220kV / 320kV).
- Cable landfall: the point at which the submarine cables are physically brought ashore.
- Onshore transition jointing pit: the interface between the offshore and onshore cables systems.
- Onshore transmission system: underground circuits, comprising up to 12 cables in trefoil arrangements in up to four separate trenches, which transmit the energy generated by the wind turbines from the landfall to the connection point.
- Onshore cabling specification (AC, voltage levels 150kV/ 220kV / 320kV).

2.3.3 Offshore TI

The OfTI will comprise:

- Up to two OSPs located within the EDA. These will house substations which will form the interface between the inter-turbine cables and the offshore transmission system;
- Transmission cables (up to four triplecore cables, separated by approximately four times water depth), buried to a target depth of a metre. Where this burial depth cannot be achieved, cable armouring will be implemented (e.g. rock placement or concrete mattresses).

Each OSP will contain as a minimum:

- Transformers;
- Switchgear;
- Reactive compensation equipment;
- Auxiliary supplies equipment; and
- Control and instrumentation necessary for the control and operation of the platforms.

The installation activities associated with the OSPs are discussed in section 2.4.2 Construction.

FOUNDATION & SUPPORT STRUCTURES FOR OFFSHORE SUBSTATION PLATFORMS

This section includes foundations and support structures for the OSPs.

The overriding factors influencing the choice of foundation and support structure for a specific project are the dimensions and weights of the electrical infrastructure to be used, nature of ground conditions in the area and water depth.

The design of the foundations and support structures for the OSPs is at an early stage. In order to provide the required level of detail on the project that will be required for the updated assessments, options are currently being considered by MORL for all of the key components detailed above, such that once the number and location of OSPs is known (by the end of 2014) it will then be possible to select the optimal foundation and support structure type.

MORL is studying the possibility of using the same foundation and substructure type as used elsewhere in the project for the wind turbines. Based on the known physical properties within the zone and the inherent uncertainty with the location of the platforms (seabed properties and water depths), one of the most versatile

and robust foundation and substructure concept is a lightweight jacket structure. The generic description of 'lightweight jacket structures' covers a number of different concepts including:

- Three and four legged lattice structure (jacket structures).
- Self elevating platforms (jack-ups).

These concepts can be tailored to suit the variable water depths and seabed gradients.

The jacket concept borrows from the expertise built up from oil and gas development experience in the North Sea.

The installation activities associated with the OSPs are discussed in section 2.4.2 Construction.

This summary represents preliminary findings, to be reviewed when site specific survey data are available. MORL is not formally ruling any particular foundation type out at this stage due to changing economic and technological circumstances that may prove one or another technology more appropriate nearer the time of construction.

All of these OSPs will include access facilities, life saving appliances and appropriate lighting and marking for surface navigation. Options for the configuration of the foundations and substructures, and details of their potential environmental effects, will be included in the updated assessments for the OfTI.

SCOUR AND IMPACT PROTECTION

The substructure and foundation concept as well as the current regime approaching seabed level defines the type and extent of scour protection required, and typically a 'scour allowance' is specified in the design of jackets. However, as foundation size increases the potential scour depth around the structure also increases and hence there is a greater need to protect the foundation, i.e. it becomes more efficient to protect the foundation rather than utilise a design scour allowance.

The suitability of installing rock or concrete mattresses for cable protection, especially around the structure bases, will be assessed based on the seabed current data across the proposed development area and the assessed risk of impact damage.

2.3.4 Onshore TI

The design of the OnTI is at an early stage. In order to provide the required level of detail on the project that will be required for the EIA, options are currently being considered by MORL for all of the key components required to facilitate the final connection to the national grid in addition to the cable infrastructure described in the previous section.

Other than the onshore substations, following construction, all infrastructure will be undergrounded.

The key components for the OnTI may consist of but not be necessarily limited to:

- Underground cables (up to 12 in four bundled trefoil arrangements in total, comprising a corridor up to 60 m wide) from landfall point to grid connection point;
- Grid transformers;
- HVAC switchgear;
- Reactive compensation;
- Auxiliary transformers;
- Control and instrumentation equipment;
- Telecoms equipment;
- Control buildings;
- Fenced compounds;
- Associated civil ground works; and
- Access roads.

2.4 TI Construction

2.4.1 Environmental Management

Prior to construction, comprehensive Environmental Management Plans (EMPs), one for the offshore and one for the onshore aspects of the TI, will be implemented in consultation with statutory consultees, with a suite of complementary management plans corresponding to different aspects of the construction activity. These EMPs will form a component part of the construction contract for the development (see Appendix 1.3 A of the MORL ES for the draft EMP which accompanied the Section 36 and OfTI Marine Licence applications). The documents, which will be tailored specifically to ensure compliance with the consent conditions for the project and current environmental best practice, will include the following:

- Monitoring Protocol (as per statutory consents);
- Incident Reporting and Non Conformance Procedure;
- Emergency Response Plan;
- Collision Risk Management Plan;
- Marine Pollution Contingency Plan;
- Flood and Water Pollution Prevention Plan (onshore);
- Dropped Objects and Materials Recovery Plan;
- Archaeological Plan;
- Noise, Dust and Vibration Management Plan; and
- Waste Management Plan.

2.4.2 Construction

Construction for the OfTI is currently anticipated to occur in phases between 2017 and 2021. Key aspects in defining the construction methodologies (and therefore the likely construction activities) will be choices on the following:

- Port(s) used as a base for the construction phase; and
- Vessels to be used for the offshore construction works.

Decisions on these will also be influenced by the nature of the substructure and foundation concept to be used for the OSPs, which will be addressed during the EIA phase. More detail on the options for ports and vessels will be provided in the updated assessments. However, for the purpose of this document, it can be assumed that the principal stages of manufacturing and transporting the various OfTI components to sites within the zone are likely to be as follows:

- Manufacture of components (including; substructures and foundations, piles (if applicable), offshore substation electrical infrastructure, HVAC subsea cables, as well as electrical components and major balance of plant items);
- Transport of components to the area;
- Storage of components as required at the port location(s) chosen as the construction base;
- Marine transportation of components to site of installation; and
- Moving construction vessels to the installation site.

It can be assumed that the key stages associated with the installation of the TI are likely to be as follows:

- Pre-construction site investigation (i.e. cone penetration testing, CPT / boreholes) (which is currently subject to separate licensing process by Marine Scotland);
- Substructure and foundation installation and associated site preparation;
- Disposal, if necessary, of any spoil excavated during installation;
- Installation of offshore substation platforms;
- Installation of HVAC cable between offshore substation platforms;
- Installation of HVAC cables between offshore platforms and the shore landing area;
- Installation of transition jointing pit at shore landing;
- Installation of HVAC cables between onshore landing area and the onshore substation; and
- Construction of onshore substations to facilitate connection to the national grid.

It should be noted that construction compounds, storage facilities, laydown areas and access / haulage tracks will be required for the onshore cable installation work construction of the onshore electrical infrastructure.

The installation of all OfTI cables to the shore from the OSPs (or vice versa) will be performed from a cable laying vessel(s). The applicability / suitability of burying the cables will be assessed using a detailed trenching review and burial protection index study.

2.5 TI Operation

2.5.1 Access to Sites

Operation of all TI assets will continue 24 hours per day; 365 days per year, and therefore the final onshore substation site identified within the proposed development area will require to be accessible at any time. Operational activities will be predominantly onshore activities with automated systems utilised to the fullest extent to ensure minimal operational activities offshore.

Scheduled maintenance activities will be confined to planned interventions for limited periods on an annual basis.

2.5.2 Lighting and Marking

The lighting and marking of the offshore OSPs will be agreed in consultation with the Northern Lighthouse Board, the General Lighthouse Authority (GLA) for Scotland and the Isle of Man, the Maritime and Coastguard Agency (MCA), the Civil Aviation Authority (CAA) and the Ministry of Defence (MOD).

The positions of the OSPs, subsea cables and ancillary structures will be conveyed to the UK Hydrographic Office (UKHO) so that they can be incorporated into Admiralty Charts and the Notice to Mariners procedures.

2.5.3 TI Control and Supervision

Once commissioned, the TI assets will operate automatically. The operation and control of the TI assets will be assessed by a Supervisory Control and Data Acquisition (SCADA) system, installed at each OSP, and at an onshore control base. The SCADA system will enable where practicable the remote control of all TI assets, as well as information transfer, storage and the shutdown of any individual asset in emergency circumstances.

2.5.4 TI Inspection and Maintenance

The TI assets will be serviced and maintained throughout their life which shall be as a minimum equal to the duration of the lease to MORL from The Crown Estate (i.e. 50 years). Maintenance or replacement of the assets is normally separated in to three categories:

- Periodic overhauls;
- Scheduled maintenance; and
- Unscheduled maintenance.

PERIODIC OVERHAULS

These will be carried out in accordance with the Original Equipment Manufacturers (OEMs) warranty. They are typically planned for execution in periods of the year with the best conditions, preferably in the summer, they will be scheduled to coincide with planned maintenance outages.

They are carried out according to the supplier's specifications and typically include function and safety tests, visual inspections, analysis of oil samples etc.

SCHEDULED MAINTENANCE

This applies primarily to inspections and testing of safety equipment, auxiliary power supplies, major balance of plant equipment and protection systems. A scheduled inspection of offshore and onshore substations is likely to occur every 12 months though specific activities may occur less frequently. Additional tasks will typically include inspection on faults and minor fault rectification.

UNSCHEDULED MAINTENANCE

This applies to any sudden defects. The scope of such maintenance would range from small defects to complete failure or breakdown of main components. Such maintenance would require the intervention of construction vessels similar to those involved with the construction of the TI.

Inspections of substructures, foundations, support structures and subsea cables will be performed on a risk based assessment basis. As such, an initial base line inspection survey will be performed, thereafter the scope and period of inspections will be determined based on the findings of each previous inspection.

2.6 TI Decommissioning

The lease term agreed with The Crown Estate for the wind farms is 50 years. Repowering will be considered at the end of the initial operating life of the wind farm. Decommissioning will be a key requirement by the Crown Estate lease agreement and Energy Act 2004 and will influence all stages of design of the OfTI, and will be addressed in the updated assessments.

The TI, cables and support structures will be decommissioned following the end of their operational life. The extent of decommissioning is dependent on the type of support structure adopted, and options will be assessed in conjunction with the design of the development in the ES.

2.7 Ports & Harbours

Ports and/or harbours will be required during the construction and operation and maintenance phases of the OfTI infrastructure. During the construction phase, deepwater ports with facilities for pre-assembly (site office, laydown areas, warehouses etc) will be required. The ports or harbours used during the operation and maintenance phase are likely to be smaller than that used during construction. MORL is in the process of identifying and agreeing which ports and harbours will be used during the lifetime of the project.

3 Cumulative and In-combination Impacts

Cumulative effects are the effects of one type of development with other types of the same development (i.e. wind farms and other wind farms, or cables with other cables). In-combination effects are the effects of the above in combination with other, different projects and activities (e.g. wind farms in combination with dredging or wind farms in combination with shipping).

Not all existing or planned infrastructure/operations will be used in each individual impact assessment. However, the following list provides an indication of any infrastructure/operations which may be used within the EIA. A section on cumulative assessment will be provided within the ES which will detail cumulative effects relating to each receptor and considering MORL's proposed TI. Developments that will be included within the cumulative impact assessment for MORL's TI include:

- Existing cable and pipelines within the Moray Firth;
- Beatrice Offshore Wind Farm transmission infrastructure;
- Proposed SHE-T cable; and
- Similar developments within the vicinity of the OnTI assets.

Developments/activities that will be included within the in-combination impact assessment for the TI include:

- Moray Firth Round 3 zone EDA, as consented;
- Moray Firth Round 3 zone Western Development Area;
- Beatrice Offshore Wind Farm, as consented;
- Beatrice demonstrator offshore wind turbines;
- Existing oil infrastructure;
- Proposed oil infrastructure developments or activities;
- Existing commercial fisheries in proximity to the proposed development area;
- Ministry of Defence operations (where known); and
- Moray Firth marina development.

In light of the potential for cumulative and in-combination effects, MORL and Beatrice Offshore Wind Limited (BOWL) have been operating the Moray Firth Offshore Wind Developers Group (MFOWDG) for the past four years, in association with The Crown Estate. The purpose of MFOWDG is to allow for collaboration to identify potential cumulative effects and ensure a standardised approach to their future assessment as part of individual project EIAs. A report has been prepared on behalf of MORL and BOWL detailing cumulative assessment methodologies for the offshore wind farm developments (ERM, 2011). This report will also support the cumulative impact assessment for MORL's and BOWL's TI development as appropriate.

MORL also intends to have discussions with other Moray Firth stakeholders to determine the potential for in-combination effects with other potential developments (onshore and offshore) in the area.

4 Consultation

4.1 Relationship and Stakeholder Engagement

MORL recognises that the proposed project will be of interest to a wide range of organisations, individuals and communities, especially in north-east Scotland, and a stakeholder engagement strategy has been produced to encourage and enable them to be part of its development (MORL, 2012).

MORL remains committed to engaging with the communities in which they operate, to address any concerns they may have. This will be achieved through the various processes detailed in our strategy, including letters, meetings, events and exhibitions, newsletters and websites.

As part of the EIA, a full public consultation will be undertaken for the onshore works. This will involve the mapping of stakeholders and representative organisations and individuals who have a geographic or topical interest in the transmission infrastructure works and their impact, in order that a communications strategy can be deployed to seek views and comment on the proposals.

The consultation will initially focus on the publication of this scoping report for the EIA; which will be distributed to identified stakeholders and their opinion sought within a defined consultation period.

Communications will be tailored to suit the geography of the chosen route, and activities during this period will include meetings with relevant stakeholder groups, local public exhibitions, and use of the local authority and community council frameworks to disseminate appropriately targeted literature to stakeholders, and to gather opinion on these proposals.

Communications with these stakeholder groups will be co-ordinated by MORL Stakeholder Manager, Craig Milroy.

5 Preliminary Environmental Considerations

This section is divided into three areas and includes the potential for effects of the proposed development on the physical, biological and human environment. A holistic approach to the EIA process will be taken, which will identify the potential inter-linking of the environmental features and the potential for “knock-on” effects.

Existing baseline information, scoping of potential effects, guidance documents and EIA methodologies are presented if the information has been available at the time of writing.

As the precise export cable corridor (onshore and offshore) and the location of the substations (onshore and offshore) have not yet been defined, the potential effects discussed below are for the current cable route corridor (offshore) and corridor search area (onshore), and the potential OSP and onshore substation search areas (see Figure 2-2, Figure 2-3 and Section 2 for project description).

5.1 Physical Environment

Key aspects of the physical environment that are relevant to understanding the potential environmental effects of construction and operation of the offshore transmission infrastructure are categorised as follows:

OFFSHORE

- Geology
- Bathymetry
- Hydrodynamics (wave climate and tidal regime)
- Sedimentary and Coastal Processes
- Underwater Noise

ONSHORE

- Superficial and Solid Geology
- Water Environment
- Contaminated Land
- Airborne Noise and Vibration

5.1.1 Data Sources

The following previously collected or developed data sources provide information on the present natural physical environment:

General

- UK Offshore Energy Strategic Environmental assessment, DECC
- SEA 5: Strategic Environmental Assessment of parts of the northern and central North Sea to the east of the Scottish mainland, Orkney and Shetland, DTI.

Additional sources for:

OFFSHORE

Geology, bathymetry and Sedimentary and Coastal Processes :

- UK Hydrographic Office Admiralty Charts
- British Geological Society
- Satellite geodesy and ship soundings by Smith & Sandwell
- SEA 5: Seabed and Superficial Geology and Processes (Holmes *et al.*, 2004)

Wind:

- UK Meteorological Office
- Beatrice demonstrator project

Hydrodynamics (waves and tides)

- UK Hydrographic Office
- UK Meteorological Office wave model data
- British Oceanographic Data Centre
- National Tide and Sea Level Facility
- Scottish Environmental Protection Agency
- Atlas of Renewable Energy Resources (BERR, 2008)

ONSHORE

Superficial and solid geology, water environment and contaminated land:

- Scottish Environmental protection Agency (SEPA)
- British Geological Survey (BGS)
- Scottish Natural Heritage (SNH)
- Registers of Scotland (ROS)

5.1.2 Physical Environment (Offshore)

The baseline environmental description is provided in the context of the southern and central Moray Firth.

Bathymetry and Geology

The following overview of the geological environment of the Moray Firth provides a context for both the metocean and sedimentary environments. Descriptions of the deeper geological units are of relevance when considering the likely nature of any potential drill arisings, if required for the offshore substation platforms.

A review of the existing bathymetry and geology for the proposed transmission infrastructure was undertaken by Senergy (2009), Metoc-Hyder (2010), ABPmer (for the MORL ES, 2012) and as part of national strategic studies by Holmes *et al.* (2004). The findings relevant to this study are summarised below.

The geomorphology (which includes the bathymetry) of the outer Moray Firth is characterised by a number of banks and deep water channels; the largest bank feature being the Smith Bank. Within the zone, where offshore substations will be located, water depths range from approximately 35 m LAT to 60 m LAT. Along the offshore cable corridor, water depths are typically 60-80 m in the central part of the Moray Firth, increasing for a short distance to up to approximately 150 m to transit the Southern Trench, depending on where the final crossing is, shoaling then relatively gradually from 60m depth to the landfall positions. The offshore export cable corridor avoids the deeper parts of the Southern Trench, which has steep slopes and maximum water depths of up to 220 m (Figure 5-1; Admiralty Chart 115; Smith & Sandwell, 1997).

The bathymetric datasets (Admiralty Chart 115; Smith & Sandwell, 1997) and assessment of a selective coverage of high resolution bathymetry data by Holmes *et al.* (2004) suggest that the seabed undulates gently across the proposed development area, gradually building up towards land, with no indications of extreme or rugged topography. It should be noted that the charted data sets do not provide the level of detail needed to define local topographic irregularities and the high-resolution data was only of limited spatial coverage.

The following summarises the geomorphology of the region as described by Holmes *et al.* (2004) Across much of the Firth, bedrock is overlain by relatively erosion resistant gravelly moraine deposits; the majority of the volume of the Smith Bank is reported to comprise such bedrock and moraine units (stabilising the long term position of the Bank). These sedimentary units are widely overlain by relatively thin layers (1-2 m thick) of Holocene sediments, mainly comprising sands and gravels but also biogenic carbonate (shell) material, in varying proportions across the Firth. Some deposition of fine (muddy) sediments has been observed in deeper channels, such as the Southern Trench and Smilers Hole along the southern margins of the Firth. In the nearshore approaches along the Aberdeenshire coast, Admiralty Charts also indicate a rocky environment with frequent sandy embayments or rocky inlets. A map of the geology within the wider Moray Firth is shown in Figure 5-2 (Source: BGS, British Geological Society).

Faulting has been detected in the Lower Cretaceous sediments up to the base of the Quaternary soils (Holmes *et al.*, 2004).

There is no evidence at this stage to suggest that shallow gas is present across the development area (Holmes *et al.*, 2004).

There is no evidence of chalk or peat deposits in the underlying geology that might be resuspended as a result of drilling activities.

The UK and the Moray Firth in particular are areas of low seismicity and the risk to offshore structures is considered to be correspondingly low (Health & Safety Executive, 2002; Holmes *et al.*, 2004).

It is also noted that there is the possibility for the occurrence of potentially hazardous unexploded ordnance (UXO) which may occur as a result of military practice within the area and historic practices of inaccurate

ammunition dumping (Senergy, 2009). This “man-made” occurrence would potentially pose a hazard to construction.

© SeaZone Solutions Limited, 2005, [012009.001, 022011.009]. This product includes mapping data licensed from Ordnance Survey (Great Britain) with the permission of HMSO. © Crown Copyright, 2006. All rights reserved. Moray Offshore Renewables Ltd © 2014. This document is the property of contractors and sub-contractors and shall not be reproduced nor transmitted without prior written approval.

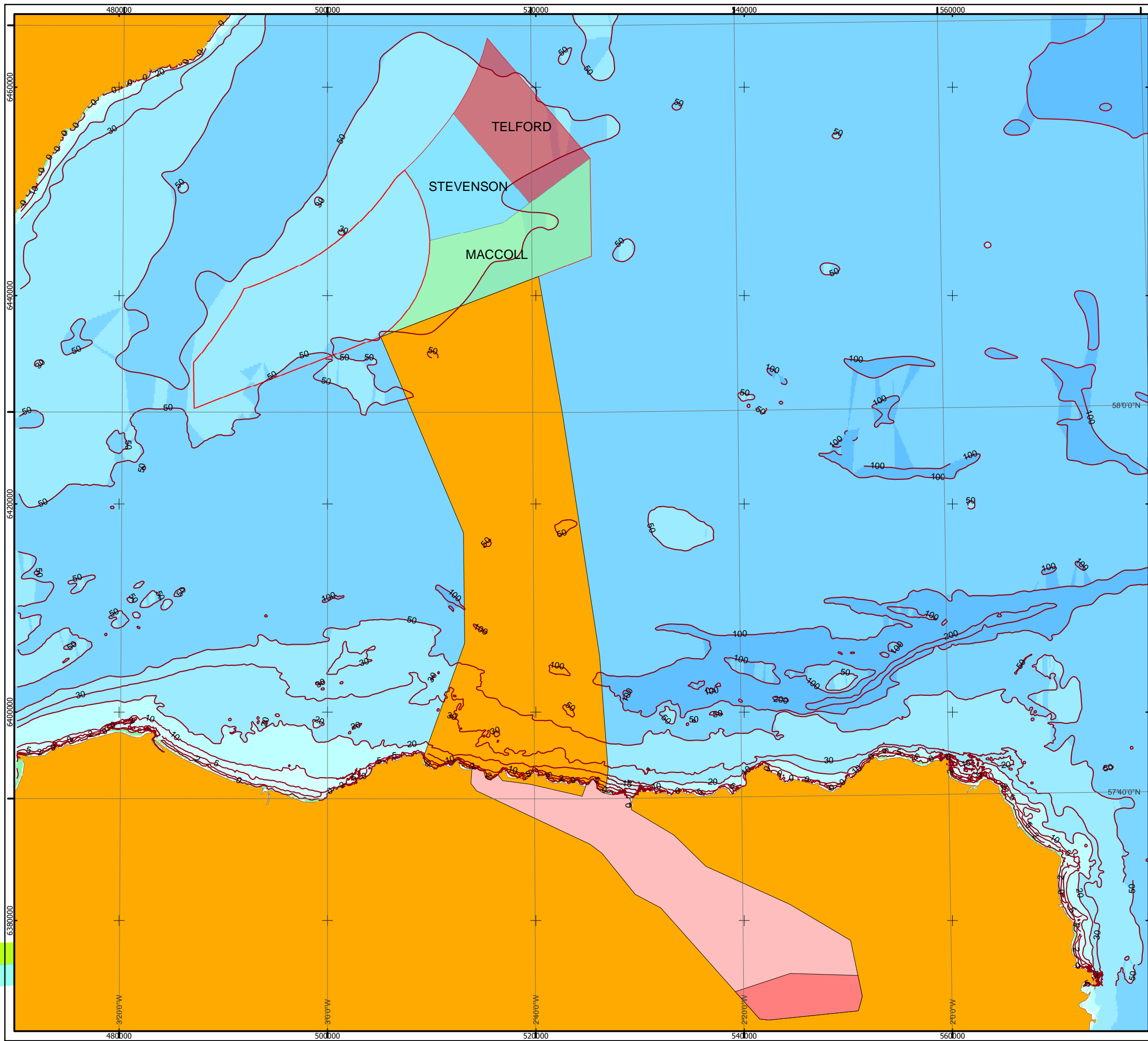

Moray Offshore Renewables Ltd

KEY

- Bathymetry Contours (m)
- Offshore Cable Corridor
- Onshore Substation Search Area
- Onshore Cable Corridor Search Area
- The Zone

Bathymetry (m)

- >10000
- <=10000
- <=5000
- <=1000
- <=500
- <=100
- <=50
- <=20
- <=10
- >=0

Horizontal Scale: 1:350,000

A3 Chart

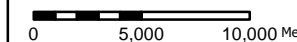

Geodetic Parameters: WGS84 UTM Zone 30N

Produced: RH
Reviewed: PM
Approved: SP

Date: 07/04/2014 Revision: B

REF: 8460001-PSO0010-MOR-MAP-035

Fig 5-1 Bathymetry of Development Area

Moray Offshore Renewables Ltd

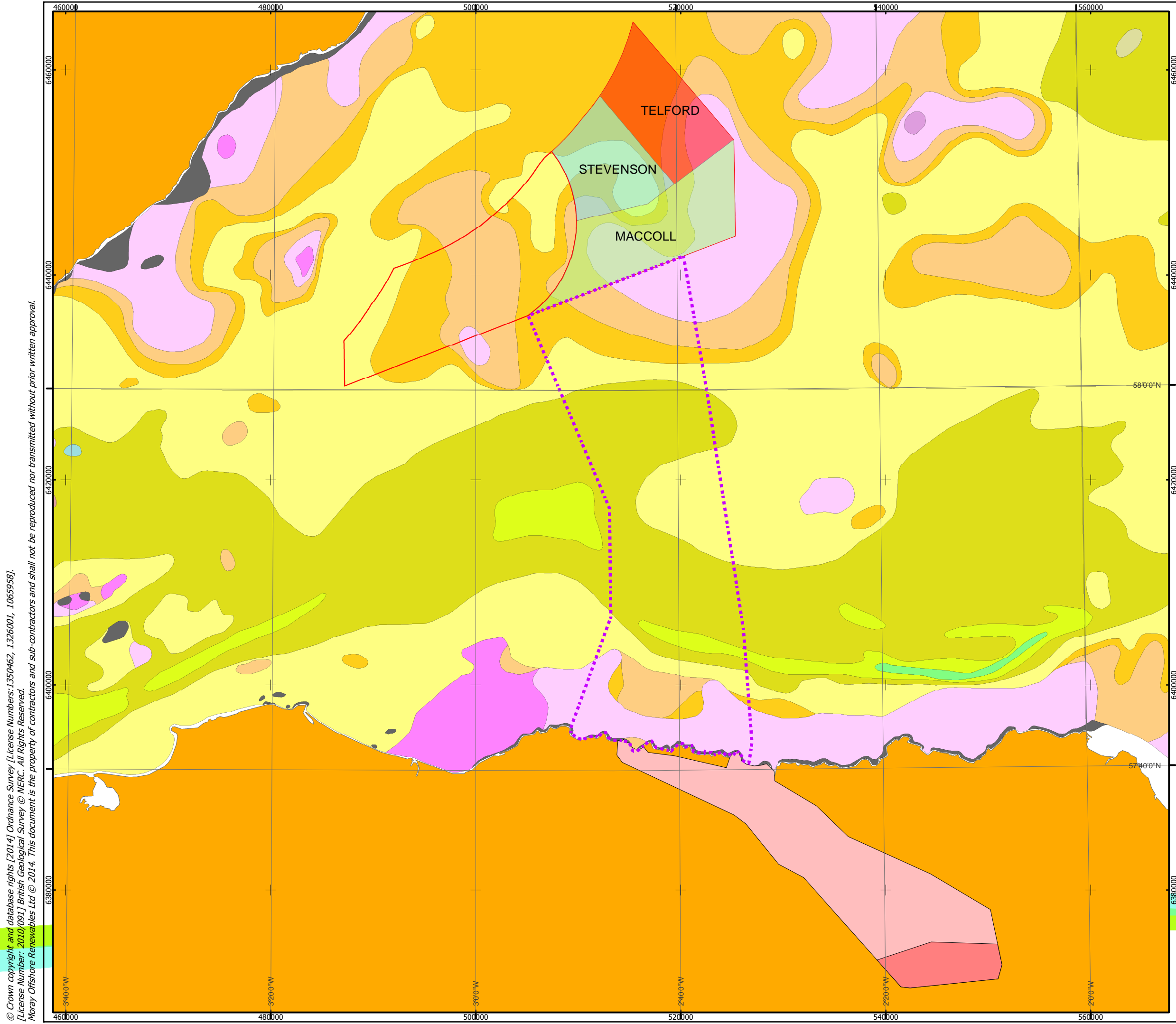

© Crown copyright and database rights [2014] Ordnance Survey [License Numbers:1350462, 1326001, 1065958].
 License Number: 2010/0911 British Geological Survey © NERC. All Rights Reserved.
 Moray Offshore Renewables Ltd © 2014. This document is the property of contractors and sub-contractors and shall not be reproduced nor transmitted without prior written approval.



Moray Offshore Renewables Ltd

KEY

- Offshore Cable Corridor
- Onshore Substation Search Area
- Onshore Cable Corridor Search Area
- The Zone
- SAND, GRAVELLY, MUDDY
- GRAVEL, MARINE
- MUD, MARINE, GRAVELLY
- SAND, MARINE, GRAVELLY
- GRAVEL, MARINE, MUDDY
- GRAVEL, MARINE, MUDDY, SANDY
- MUD
- SAND, MARINE, MUDDY
- GRAVEL, SANDY, MARINE
- MUD, MARINE, SANDY
- SAND, MARINE, GRAVELLY, MUDDY
- SAND, MARINE, GRAVELLY
- SAND, MARINE
- ROCK (UNDIFFERENTIATED)

Horizontal Scale: 1:350,000 A3 Chart

Geodetic Parameters: WGS84 UTM Zone 30N

Produced: RH
 Reviewed: PM
 Approved: SP

Date: 07/04/2014 Revision: B
 REF: 8460001-PSO0010-MOR-MAP-036

Fig 5-2 Marine Geology of Moray Firth

Moray Offshore Renewables Ltd

Metocean Environment

The following overview of the metocean climate provides an indication of the magnitude and variability of the driving forces to the sedimentary environment. Of particular relevance is the wind and wave climate, which is shown in the following section to largely control sediment transport and natural turbidity in the central parts of the Firth. Tidal processes, playing a secondary but not insignificant role in guiding the direction of sediment transport, are shown to be largely benign in most parts of the route.

WIND CLIMATE

The following summary of wind climate in the Moray Firth is important to the study in so far as it controls the wave climate. Wave climate will be shown in the next section to be the dominant control on sediment transport processes in the outer Moray Firth and within the proposed development.

Wind data most closely representative of the Moray Firth and the length of the cable route are currently available from two sources. Long term hindcast data are available from meteorological models (including the Met Office and NCEP/NCAR Reanalysis I and II). These have been analysed to provide annual and monthly frequency statistics based on up to 34 years of hindcast data. The primary source for in-situ measured wind data in the outer Moray Firth is a LiDAR installation on the Beatrice Alpha platform, which was installed in 2006 to support the Beatrice Demonstrator project. The measured data are of too short duration to determine accurate statistics of wind climate directly, but are used to tune and validate the longer hindcast data sets.

The annual average statistics are summarised in Figure 5-3 in the form of a wind rose for the full data set (all year conditions). The figure shows that winds typically originate from south-westerly directions with wind speeds typically less than 12m/s. During summer months, wind speeds are typically lower but are more likely to come from a wider range of wind directions. Stronger winds (from 12 to 25m/s) tend to occur in winter months and dominantly come from south-westerly through to northerly directions. The frequency of relatively calm conditions (<2m/s wind speed) is also seasonal (i.e. more frequent in summer months); calm conditions occur approximately 5% of the year on average.

TIDAL REGIME

The Moray Firth is characterised by a progressive, open coastal tidal regime. The tidal wave initially approaches from the north, from the northern North Sea, becoming aligned to the axis of the Firth in central parts. At the start of the offshore cable corridor, the maximum astronomical tidal range (at the northern coast of the outer Moray Firth) is 3.9 m, i.e. a meso-tidal environment. Tidal range is known to increase gradually with distance into the Moray Firth and at the end of the revised cable corridor, the maximum astronomical tidal range might be up to 10% larger. However, along the entire corridor, the tidal range is relatively small in comparison to the typical total water depth (60 to 150 m).

Tidal currents along most of the cable route are notably weak, with peak near surface mean spring current speeds of less than 0.3-0.4kts (0.15-0.21m/s); tidal current speeds are typically less near to the bed and for a significant proportion of the time during times of non-peak flow, slack water and also generally during neap tidal conditions. Tidal current streams are typically aligned to the adjacent coastline over much of the region but tend to rotate in central parts to describe a smooth sweep of the tide into, across and out of the Firth.

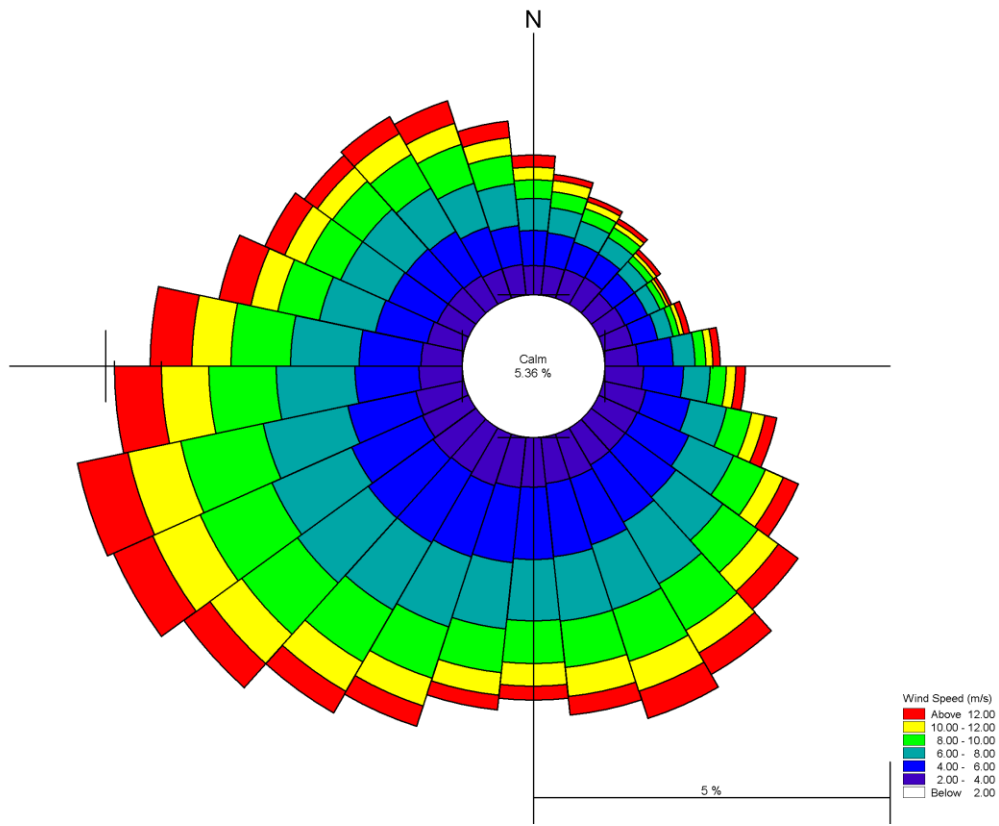

Figure 5-3: Wind Rose for the Outer Moray Firth. Based on NCEP Reanalysis II hindcast winds (hourly from Jan 1979 to Dec 2009).

Both tidal range and therefore tidal current speed predictably vary on a variety of timescales from hours (tidal cycle) to weeks (spring-neap) to months (solstice-equinox) to years (the 18.6 year nodal cycle). Mean water levels may also vary over the lifetime of the development as a result of a combination of climate change affecting mean sea level globally and regional post-glacial rebound of the underlying geology.

Significant storm surges are generally reported to be of relatively small amplitude in the Moray Firth, in comparison to the larger values observed elsewhere in the North Sea (2 to 3m). This is attributed to the protection afforded by the position, shape and relative orientation of the Firth in the North Sea. The modelled extreme, depth averaged, surge currents over 50 years in the Moray Firth are about 0.60 to 0.80m/s (Flather, 1987). It should be noted that, depending on their timing, storm surge effects can either be relatively accentuated or negated by normal tidal processes.

WAVE CLIMATE

The outer Moray Firth is exposed to large storm driven waves with long wave fetches from offshore directions. The largest fetch for wave development is from the north through to north-east, however, depending on the actual direction of approach, the position of the OSP infrastructure within the zone behind the Wick peninsula may offer variable degrees of protection, potentially leading to variation in wave exposure over the site.

The height of short to intermediate fetch length wind waves generated within the Firth will depend upon the wind direction as well as the speed, which controls the wave fetch length. The previously described wind climate suggests that wave climate and storm intensity will be seasonal in nature and will include a wide range of approach directions.

The offshore wave climate may be variably modified at the coastline where waves experience shoaling and refraction as they move into shallower water. These processes are not generally important to the OSPs or the offshore cable corridor, except closer to the point of landfall.

CLIMATE CHANGE

Climate change is an important and contemporary issue that may potentially affect the normal baseline environmental conditions at the proposed sites over the lifetime of the proposed OfTI development; the predicted effects of climate change are irrespective of the development's presence or chosen design. Of most relevance to an offshore wind development including OfTI, climate change is predicted to cause a rise in mean sea level and an increase in average storm intensity with time. The exact magnitude and rate of these changes are not widely agreed at present due to the uncertainty involved in predicting climate change. However, the UK government does issue guidelines for appropriate consideration of these factors.

The effects of climate change are likely to be most evident along the shorelines where much of the wave energy is ultimately dissipated, potentially leading to modified rates of littoral sediment transport. The advancing position of mean high water on beaches may also lead to wave energy dissipation higher up on the foreshore with anticipated beach loss and scour in front of sea walls. In offshore areas, the relative water depth over sandbanks may increase, leading to greater exposure of the coast to the larger waves from offshore directions. Any potential effect of the proposed wind farm development will also need to be considered within the context of these natural changes.

Increased wave energy offshore may have consequences for the frequency and magnitude of sediment transport events resulting in elevated levels of suspended sediment concentrations (SSC) within the area, despite any influences brought about by the proposed development.

Sedimentary Environment

REGIONAL SEDIMENTARY PROCESSES

The following overview of regional sedimentary processes demonstrates the stable nature of the regional geology of the Moray Firth where sedimentary bodies largely comprise relic (erosion resistant and stable) features. Also, that sedimentary processes are typically low-energy and dominantly episodically wave driven. A

further consideration of naturally occurring sediment resuspension reaffirms the importance of storm waves in driving such processes.

On the basis of the observed bed features and the sediment types (see section 0) present in comparison to the typical wave climate and tidal regime, sediment transport processes in the outer Moray Firth are considered unlikely to be driven by the normal tidal currents alone. Rather, the evidence shows that the magnitude of sediment transport processes is dominated by less frequent but more energetic storm events through wave action at the seabed; however, the direction of transport typically remains orientated to the tidal axis. Storms may have a relatively greater or lesser frequency and magnitude of effect in different parts of the Moray Firth as the strength of wave action felt at the bed is moderated by the local water depth and the relative exposure of the particular location.

In the nearshore environment, the rocky inlets and sandy embayments suggests that coastal processes at the coastline will be spatially variable in type and also therefore in response and susceptibility to the potential effects of the proposed development.

SUSPENDED SEDIMENTS

As outlined in the following section, the strength of the normal tidal regime in the Moray Firth is considered insufficient to drive significant sediment transport alone. Local processes are instead thought to be dominated by nearbed wave action during occasional high-energy storm events. As a result, SSC, especially in the upper water column, will be typically low during periods of calm weather and/or in the absence of large swell waves.

However, levels of SSC can also be expected to rise significantly, both nearbed and extending upwards into the water column, during and for a short time after storm events when wave action at the seabed is sufficient to mobilise and resuspend the local sediments. Following a storm event, SSC will gradually decrease (settle out) to a baseline condition, controlled by the ambient regional tidal regime. The degree of local seabed disturbance and the resulting levels of SSC will depend upon the duration and intensity of the storm and the resulting character of the waves that are produced; local variability in SSC may also be observed depending upon the local sediment type (resistance to erosion, tendency to remain in suspension) and water depth (controlling wave attenuation).

There are no known significant fluvial sources of SSC in the outer Moray Firth.

Due to the seasonal nature of the frequency and intensity of storm events, levels of SSC will likely follow a broadly seasonal pattern. It is possible that seasonal blooms of marine organisms may also contribute to seasonality in measurements of total turbidity, but this is not directly associated with resuspension of (inorganic) sediments.

5.1.3 Data Gaps

The body of available historical data describing the physical environment are not presently of sufficient quantity, quality and resolution to support detailed amended assessments or the engineering design of the offshore wind farm and certain aspects of the cable route design. To fill these data gaps, more detailed metocean and geophysical survey data has been collected in the vicinity of the main site and additional geophysical data is being collected along the cable corridor. The combined data set will be used to more accurately predict the potential for effects of the development on known sensitive receptors.

5.1.4 Environmental Impact Scoping

Based on the available literature, it is considered that the potential effects on the physical environment as a result of constructing, operating and decommissioning the OfTI may include:

Effect Description	Potential site specific effect	Potential cumulative and/or in-combination effect
Changes to hydrodynamic (wave and tidal) conditions	✓	✓
Changes to the sedimentary environment	✓	✓
Changes to sedimentary structures	✓	✓
Changes to suspended sediment concentrations	✓	✓

Consideration of the above issues will be made with respect to the following spatial scales, as relevant to the proposed cable and offshore substation infrastructure:

- Near-field (i.e. the area within the immediate vicinity of the proposed works); and
- Far-field (e.g. the coastline, sites of scientific and conservation interest).

Site-Specific Impact Assessment Methodology

For each of the potential effects described above, the potentially present sensitive receptors, the surveys or studies required to address outstanding data gaps and a proposed method of impact assessment are described in the tables below. In each case, a more specific list of sensitive receptors relevant to the site will need to be identified via the scoping and stakeholder feedback.

Potential Effect	Changes to hydrodynamic conditions from the OSPs
Sensitive Receptors	<p>Potentially sensitive receptors include:</p> <ul style="list-style-type: none"> - Surfing wave climate on the south coast of the Moray Firth. - Safety of nearby offshore infrastructure affected by modified wave climate. <p>And, if identified during stakeholder engagement:</p> <ul style="list-style-type: none"> - Navigational safety in the vicinity of adjacent ports affected by modified wave climate.
Survey/Study Proposed to Assess Effect	<p>To inform studies to determine the potential for effects on the wave and tidal regime, the following surveys and studies have been or will be undertaken:</p> <ul style="list-style-type: none"> - Identification of key recreational surfing venues and identification of key port and offshore infrastructure. - Bathymetric surveys - Metocean surveys: ADCP surveys and wave buoys - Computational modelling
Method of Impact Assessment	<p>A more specific list of sensitive receptors will be identified for study. Historical and newly collected survey data will be used to inform conceptual and numerical modelling which will be used in turn to determine the magnitude, extent and significance of changes in the wave climate within the Outer Moray Firth affecting the identified sensitive receptors.</p>

Potential Effect	Changes to the sedimentary environment & Changes to sedimentary structures
Sensitive Receptors	<p>Potentially sensitive receptors include:</p> <ul style="list-style-type: none"> - The form and function of the Moray Firth surficial sediments. - The form and function of the littoral and nearshore zone at the cable landfall. - Sediment transport pathways affecting the form and function of similar adjacent sedimentary systems. - Changes to patterns of coastal sediment transport affecting coastal stability and recreational beach resource. - Loss of habitat due to sediment displacement as a result of scouring around the base of offshore substation platform foundations.
Survey/Study Proposed to Assess Effect	<p>To inform studies to determine the potential for effects on the sedimentary environment during the operational phase of the wind farm, the following surveys and studies have been or will be undertaken:</p> <ul style="list-style-type: none"> - A more detailed review of sedimentary information including the location of potentially susceptible coastlines in the Moray Firth region and at the cable landfall. - Bathymetric surveys - Side-scan sonar - Benthic survey and review of key habitats present - Metocean surveys: ADCP surveys and wave buoys - Seabed sediment samples & particle size analysis - Suspended sediment concentration monitoring - Computational modelling
Method of Impact Assessment	<p>A more specific list of sensitive receptors will be identified for study. Historical and newly collected survey data will be used to inform conceptual and numerical modelling which will be used in turn to determine the magnitude, extent and significance of changes in the sedimentary environment affecting the identified sensitive receptors.</p>

Potential Effect	Changes to suspended sediment concentrations
Sensitive receptors	<p>Potentially sensitive receptors include:</p> <ul style="list-style-type: none"> - Habitats and ecosystems sensitive to modification of the naturally present levels of suspended sediment or rates of sediment deposition (if found to be present).
Survey/Study Proposed to Assess Effect	<p>To inform studies to determine the potential for changes to normal patterns and levels of suspended sediment concentration during the construction (foundation and cable installation) and operational phases of the wind farm development, the following surveys and studies have been or will be undertaken:</p> <ul style="list-style-type: none"> - Benthic ecology surveys - Bathymetric surveys - Side-scan sonar - Metocean surveys: ADCP surveys and wave buoys - Seabed sediment samples & particle size analysis - Suspended sediment concentrations - Sub-bottom geophysical survey and vibro-coring - Computational modelling
Method of Impact Assessment	<p>A more specific list of sensitive receptors will be identified for study on the basis of the benthic surveys, informed by the detailed bathymetric and side-scan sonar surveys. If sensitive receptors are found to be present, historical and newly collected survey data will be used to inform conceptual understanding in conjunction with numerical modelling which will be used in turn to determine the magnitude, extent and significance of changes in the typical levels of suspended sediment concentration and their potential for re-deposition.</p>

The following issues have been considered and are scoped out of the proposed study:

- Due to the presence of only a thin layer of mobile Holocene sediments overlying erosion resistant sedimentary units on the Smith Bank, it is considered that there will be no significant effect of the OSP foundations on the underlying geology of the main wind farm site or the regional bathymetry. In other locations along the offshore cable corridor, the cable will be buried or will present only a small local obstruction at the surface (similar in scale to naturally occurring bedforms) and therefore presents little or no risk of causing gross morphological change. Therefore, these subject areas have been **scoped out**.
- Where the cable is buried, presenting no obstacle to nearbed water flow, it is considered that there will be no significant effect on the tidal or wave regimes, and therefore no significant effect on coastlines, sediment transport pathways or navigational safety, either near to the offshore export cable infrastructure or in the surrounding area. Therefore, this subject area has been **scoped out**.
- The presence of UXO is not considered as a potential effect on the environment but will be considered a potential effect on the safety of the construction programme.

Cumulative and In-Combination Impact Assessment

Cumulative effects arise where the footprints of potential effects (e.g. areas of reduced wave height or tidal current speed) of two or more simultaneously present developments overlap, resulting in a greater potential effect locally.

In-combination effects may arise where the footprint of temporary effects (e.g. plumes of suspended sediment) from two or more simultaneously occurring operations overlap, resulting in a greater potential effect locally. Operations with the potential to result in in-combination effects may also include other marine operations unrelated to the OfTI construction such as cable or pipe laying and dredging.

There is foreseeable potential for the extent or magnitude of environmental effects identified in the previous sections to be cumulatively increased by the simultaneous presence and construction activities of the Beatrice offshore wind farm transmission infrastructure and the proposed SHE-T cable.

The extent to which in-combination effects may arise, will depend upon the anticipated construction schedules of the OfTI the Beatrice offshore wind farm and the SHE-T cable. No other regular activities with potential to cause in-combination effects were identified in the Outer Moray Firth apart from possible future oil and gas developments.

SHE-T is obliged to develop a transmission connection for renewable energy projects on the Shetland Isles (e.g. Viking Wind Farm project). SHE-T have proposed a High Voltage Direct Current (HVDC) connection between the converted station at Upper Kergord, Shetland and Blackhillock, Scotland, for which the subsea section would cross the proposed TI infrastructure.

The methodologies with which cumulative and in-combination effects will be assessed are described in the Moray Firth Offshore Wind Developers Group Cumulative Impacts Assessment Discussion Document (ERM, 2011).

Site Specific Survey Methodology

BEST PRACTICE GUIDANCE

The survey designs will take into consideration industry best practice for each survey type and best practice survey/data requirements to inform upstream modelling and analysis methods which are foreseeably part of EIA. These will ensure both a sufficient quantity and quality of data are collected:

- Marine Guidance Note MGN 371 (compliance with International Hydrographic Organisation (IHO) Order 1 standards)
- CEFAS (2004). Offshore Wind Farms – Guidance note for Environmental Impact in respect of FEPA and CPA requirements.
- Cefas (2011). Guidelines for data acquisition to support marine environmental assessments of offshore renewable energy projects. ME5403.
- COWRIE (2009) Coastal Process Modelling for Offshore Wind Farm Environmental Impact Assessment: Best Practice Guide. Eds: Lambkin, D.O., Harris, J.M., Cooper, W.S., Coates, T.
- SUT (2005). Guidance Notes on Site Investigation for Offshore Renewable Energy Projects (UK Society for Underwater Technology (SUT))
- JNAPC (2006). JNAPC Code of Practice for Seabed Development – Joint Nautical Archaeology Policy Committee

Summary of Methodology

GEOPHYSICAL SURVEYS

Geophysical surveys for the offshore export cable route will commence in April 2014 and are expected to be complete by early summer 2014.

An analogue survey shall be undertaken to provide data on bathymetry, seabed features, and sub-bottom conditions to at least 5 m depth below seabed for input to the Trenching Specification and Burial Protection Assessment (BPA).

The geophysical survey will therefore be conducted using swath bathymetry, side scan sonar, sub-bottom profiler and magnetometer along the proposed cable route. The seabed hydrographic and geophysical data will also provide the basis for benthic ecology and marine archaeology assessments and input to the environmental programme. Geophysical surveys are executed using remote sensing equipment that is either installed on the hull of the vessel or towed below the vessel but above the sea bed. A 'picture' is built up of the seabed geophysical conditions as the vessel transits across the sea surface. In order to efficiently cover the seabed surface the survey area is covered by transiting in lines, the spacing of which is dependent on the water depth.

GEOTECHNICAL SURVEYS

Geotechnical surveys will be used to establish the seabed conditions against which geophysical data can be correlated and used to determine and quantify surficial and sub-surface sedimentary conditions. Following the execution of the detailed geophysical survey, and the integration of the results into a geo-spatial model, the number of geotechnical sampling locations will be finalised in order to define the seabed structure for the OSPs and along the offshore cable corridor.

For the OSPs and offshore cable corridor, a sufficient number of samples shall be obtained from each surface seabed unit along the route(s) to identify and classify the material aiding the assessment of installation requirements. Such testing will serve to confirm the nature of the surficial soils, archaeological features and further reduce the installation risk.

Shallow geotechnical testing will be carried out at strategically selected intervals, at locations to be selected from the results of the analogue survey. The shallow geotechnical sampling programme is designed to provide information on soil properties in the top 5 m below seabed. It should be noted that there will not be any boreholing undertaken.

The following tools shall be used in the geotechnical surveys:

- 5 m vibrocorer to obtain samples of Holocene or near-surface Quaternary soils for laboratory analysis
- 5 m Piezocone Penetration Tests (PCPT) to determine geotechnical properties of the soils.

Vibrocore and PCPT stations shall be co-located within a few metres of each other.

METOCEAN SURVEYS AND MODELLING

The metocean campaign commenced in June 2010 and was completed in May 2011. The campaign included one directional wave buoy and four seabed frames each with an acoustic doppler current profiler (ADCP, measuring wave climate, tidal height and tidal current profiles), an optical backscatter device (OBS, measuring suspended sediment concentration) and a static sediment trap. The wave, tidal and turbidity data that was collected will be used to inform and validate coastal process models of the area. A limited amount of seabed sediment sampling was also undertaken at the locations of the deployed devices in addition to other seabed sampling programmes. The wave buoy was in the water until a representative range of typical conditions were successfully observed (including calm and storm events and at least one 1 in 1 year event from each of the three characteristic wave fetch sectors). The seabed frames were deployed for a minimum of 29 consecutive days to provide at least two full neap-spring tidal cycles of concurrent tide, wave and turbidity data. Figure 5-4 illustrates the locations of the equipment.

A numerical model of coastal process and metocean conditions will be designed and applied within the study according to best practice guidance for numerical modelling in relation to EIA for offshore wind farms (COWRIE, 2009). Once suitably calibrated and validated using the measured data from the site, together with historical data available for other locations along the offshore export cable route, the numerical model can be used to inform assessments at any location along the route of the magnitude and significance of effects to any sensitive receptors identified, caused directly by changes to the following environmental processes:

- Hydrodynamics (e.g. wave climate, tidal regime);
- Sedimentary environment (e.g. sediment composition and particle size, sediment re-suspension, sediment transport pathways and sediment deposition);
- Sedimentary structures (e.g. channels, banks); and
- SSCs.

The results of these studies, including input from numerical modelling will also be used to inform the following associated impact assessments:

- Benthic ecology
- Fish ecology
- Offshore archaeology and culture heritage
- Offshore recreation
- Potential cumulative and in-combination effects





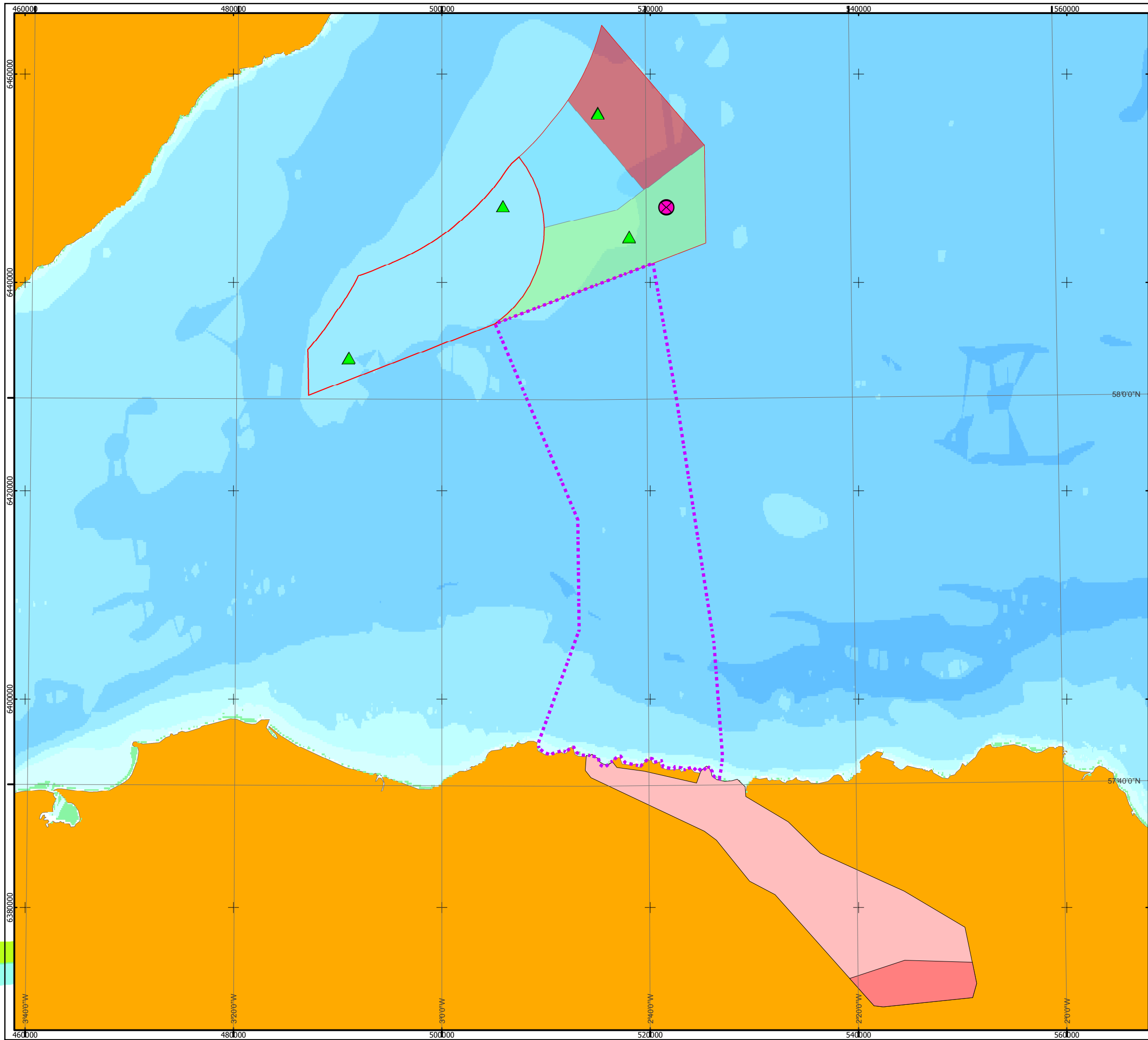

Meteorology (primarily wind) data is expected to be collected from a combination of methods, such as onshore met masts and weather stations, offshore based LiDAR and, later in the development programme, an offshore met-mast.

© SeaZone Solutions Limited, 2005, [012009.001, 022011.009]. This product includes mapping data licensed from Ordnance Survey (Great Britain) with the permission of HMSO. © Crown Copyright, 2006. All rights reserved. Moray Offshore Renewables Ltd © 2014. This document is the property of contractors and sub-contractors and shall not be reproduced nor transmitted without prior written approval.



Moray Offshore Renewables Ltd

KEY

-  AWACs
-  Wave Buoys
-  Offshore Cable Corridor
-  Onshore Substation Search Area
-  Onshore Cable Corridor Search Area
-  The Zone

Horizontal Scale: 1:350,000

A3 Chart

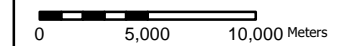

Geodetic Parameters: WGS84 UTM Zone 30N

Produced: RH
 Reviewed: PM
 Approved: SP

Date: 07/04/2014 Revision: B

REF: 8460001-PSO0010-MOR-MAP-038

**Fig 5-4 Metocean Survey
 Equipment Deployed**

**Moray Offshore
 Renewables Ltd**

Potential Mitigation Methods

Potential mitigation measures associated with changes to the sedimentary environment include the type and design of OSP substructure and foundation, the use of scour mats around bases and the choice of construction techniques, including installation of foundations and cable burial.

The mitigation measures proposed in the final ES will be dependent upon the infrastructure choices available after the preliminary front end engineering design (FEED) work (which will be influenced by engineering properties of the area and the cost of materials) and the potential effects to sensitive receptors found to be present, as determined by the scoping and further studies. Options of mitigation will be discussed with the relevant authorities.

5.1.5 Underwater Noise

During the development of OfTI a number of possible sources of underwater noise may be present in the region. These will be related to the construction of the OSPs and the laying of the offshore section of the export cable.

Some offshore construction operations are known to generate high levels of underwater noise that may be of sufficient level to affect local marine life, in particular fish and marine mammals. Specific information relating to the EIA scope for these animals is presented in the relevant sections of this document (sections 5.2.3 and 5.2.4). This section provides some additional specific detail relating to the proposed approach to underwater noise assessment.

MORL has gained consent for the offshore generating station (OGS) element of the Project. Therefore, EIA has been undertaken for the most sensitive species to the effects of underwater noise. These findings will inform the updated TI assessments to ensure the most relevant information is incorporated in the assessment.

Baseline Environment

Factors affecting the pre-existing baseline levels of underwater noise in the region typically relate to activities such as:

- Shipping;
- Metocean conditions;
- Oil and gas activities; and
- Leisure craft.

Data gaps

The levels of underwater noise from these activities can often be characterised by reviewing measured underwater noise data from similar activities and carrying out simple modelling to better understand the effect in a specific region. A review of the available information will be carried out including incorporation of knowledge from the MORL ES (2012) to inform the updated assessments.

Environmental Impact Scoping

Based on the available information, the following are perceived to be the potential effects relating to underwater noise generated by the proposed OfTI:

Effect Description	Potential site specific effect	Potential cumulative and/or in-combination effect
Behavioural disturbance or physical injury to marine species as a result of increased levels of underwater noise	✓	✓

Activities related to the construction, operation and maintenance of the transmission infrastructure that may generate increased levels of underwater noise include but may not be limited to:

- Impact piling or drilling of foundations for the OSPs
- Trenching of cables
- Vessel activity

Site Specific Impact Assessment Methodology

For each of the potential effects described above a survey or study and method of impact assessment is described in the tables below.

Potential Effect	Behavioural disturbance or physical injury to marine species as a result of increased levels of underwater noise
Sensitive Receptors	Potentially sensitive receptors include: <ul style="list-style-type: none"> - Marine mammals - Fish
Survey/Study Proposed to Assess Effect	To determine the potential for behavioural disturbance and physical injury as a result of underwater noise, the following surveys and studies will be undertaken: <ul style="list-style-type: none"> - Desk based information and literature review of offshore activities and available data relating to underwater noise from these activities - Computational modelling
Method of Impact Assessment	Previously measured underwater noise data from similar sources of underwater noise will be reviewed along with any site specific data recorded during additional surveys. These data will be analysed to determine the magnitude and extent of potential effects to marine species or species groups from these activities. Detailed site specific computational modelling will be undertaken to estimate the effects on local key species.

Site Specific Survey Methodology

BEST PRACTICE

There is currently no best practice guidelines specific to the modelling of underwater noise for the EIA process. However, three publications may be applicable to the assessment of underwater noise effect on marine life and the measurement of underwater noise from vessels. These are:

- Joint Nature Conservation Committee (JNCC), Natural England and Countryside Council for Wales. (2010). The protection of marine European Protected Species from injury and disturbance: Guidance for the marine area in England and Wales and the UK offshore marine area, June 2010
- For the measurement of noise from vessels, the guidance set out in ANSI, S12.64, Quantities and Procedures for Description and Measurements of Underwater Sound from Ships, Acoustical Society of America, 2009, will be considered.
- Marine Scotland (2014). The protection of marine European protected species from injury and disturbance: guidance for Scottish inshore waters.

Site Specific Underwater Noise Modelling Methodology

The marine species of interest to the study area will be defined by the relevant specialists; further scoping information on this can be found in the appropriate sections in this document. The purpose of this section is to provide details of the intended approach to underwater noise prediction that will provide the data required to assess the effect of underwater noise on various marine species.

INFORMATION AND LITERATURE REVIEW

Initially, a review of the available information relating to the various processes involved in the offshore transmission works will be carried out. This will include details such as specification of equipment used, materials, vessel specification and any other relevant information that is available.

A literature review will then be carried out to determine if any information exists that could indicate the levels of underwater noise that may be generated during these activities.

RANK ORDERING OF NOISE SOURCES

Where underwater noise data of sufficient quality are available, these will be used to rank order the noise sources in terms of potential effect to marine species. This will allow sources of underwater noise that are judged to be of a sufficiently low level to have negligible effect to be removed from further consideration.

DETAILED NOISE MODELLING

Modelling of underwater noise will then be carried out to estimate the potential effect of the remaining noise sources on marine species. Various noise propagation models are available for this purpose so the most appropriate model will be used for the intended purpose (the modelling approach of the transmission infrastructure will be aligned with the offshore generating station assessment, see MORL ES, 2012.).

The output of the noise modelling exercise will be in the form of effect zone contour plots showing the zone around the activity within which various effects are likely to occur to marine species. A critical part of the process is to analyse the noise in a way that will indicate its potential for environmental effect. That is, to assess the environmental effect of noise, the modelled data must be interpreted and processed in a biologically significant way.

The high levels of underwater noise generated during some offshore construction operations have the potential to cause both physical and behavioural effects in species of fish, marine mammals and diving birds. These can be summarised as:

- **Lethal Effect** - At very close range from the source the peak pressure levels have the potential to cause death, or severe injury leading to death, in marine mammals, fish and diving birds.
- **Physical Injury** - At greater range, underwater noise can cause physical injury to organs such as the lungs, liver, intestines, and other soft tissues surrounding gas containing structures of the body.
- **Hearing Impairment** - At high enough sound levels and particularly where there are repeated high level exposures from activities such as impact piling, the underwater sound has the potential to cause hearing impairment in marine species.
- **Behavioural Response** - At greater range the underwater sound wave may not directly injure animals, but has the potential to cause behavioural disturbance. This effect is slightly harder to predict as there are many other factors that may influence whether an animal will react to a sound or not. Factors such as age,

sex or a strong compulsion to enter an ensonified area may determine whether or not a particular individual will react to a sound. Metrics have, however, been developed to inform an assessment of the likelihood of a particular animal reacting to a sound.

A number of metrics have been proposed for the assessment of the effect of underwater noise on marine species. Details of the metrics most commonly used and their application to the EIA process can be found in the following documents:

- Nedwell J R, Turnpenny A W H, Lovell J, Parvin S J, Workman R, Spinks J A L, Howell D (2007). A validation of the dBht as a measure of the behavioural and auditory effects of underwater noise. Subacoustech Report Reference: 534R1231, Published by Department for Business, Enterprise and Regulatory Reform
- Joint Nature Conservation Committee (JNCC), Natural England and Countryside Council for Wales. (2010). The protection of marine European Protected Species from injury and disturbance: Guidance for the marine area in England and Wales and the UK offshore marine area, June 2010
- Southall, Brandon L.; Bowles, Ann E.; Ellison, William T.; Finneran, James J.; Gentry, Roger L.; Greene, Charles R.; Kastak, David; Ketten, Darlene R.; Miller, James H.; Nachtigall, Paul E.; Richardson, W. John; Thomas, Jeanette A.; Tyack, Peter L, (2007) Marine Mammal Noise Exposure Criteria Aquatic Mammals, Vol 33 (4)

The field of underwater noise impact assessment is constantly changing as our understanding improves. Therefore, other criteria and any update to the metrics presented in the above sources will be considered in the assessment, where appropriate.

Cumulative and In-combination Impact Assessment & Survey Methodologies

The potential for cumulative effect will be assessed by review of the construction schedule. Where activities related to the OFTI are likely to occur at the same time, the cumulative effect will be assessed.

Due to a number of other projects in the Moray Firth region, in particular the construction of other offshore wind farms, subsea cables and oil and gas activities, in-combination effects are possible. A review of the available scheduling information will be carried out and the likelihood and extent of any increase in effect will be assessed.

The MFOWDG Cumulative Impacts Assessment Discussion Document (ERM, 2011) and associated consultation responses recognise the importance of the underwater noise modelling in the assessment of potential effects on marine fauna, specifically marine mammals, fish and diving birds. A similar approach will be followed for the cumulative impact assessment associated with MORL and BOWL's transmission infrastructures.

Potential Mitigation Methods

A number of possible mitigation strategies will be considered in the updated assessments, such as best practice guidance and monitoring protocols as well as potential site specific methods.

5.1.6 Physical Environment (Onshore)

The physical environment receptors are categorised as follows:

- Superficial and solid geology
- The water environment
- Human health

Baseline information

GEOLOGY

The BGS 1:650,000 scale GIS map indicates that superficial deposits expected to underlie the onshore cable corridor search area will include (Figure 5-7):

- glacial sands and gravels;
- till;
- Raised Marine Deposits (Undifferentiated); and
- Alluvium.

The solid geology within the onshore cable corridor search generally comprises psammites and pelites of the Southern Highland Group with a band of Middle and Lower Old Red Sandstone at the approximate mid point of the search area. Isolated pockets of Appin and Argyll Groups (Metalimestone, Pelites, Calcsilicate-Rock, Psammite, Semipelite and Quartzite, Figure 5-5) form a more diverse area of geology at the western end of the corridor search area. The following igneous intrusions are also recorded within the onshore cable corridor search area, at its eastern and western extents:

- Neoproterozoic felsic rock;
- Ordovician to Silurian ultramafite; and
- Ordovician to Silurian mafic igneous rock.

Dykes of Carboniferous to Permian dolerite and Tholeiitic basalt also intersect the substation search area.

A number of faults cross the onshore cable corridor search area, at the western end and bounding the western periphery of the Old Red Sandstone.

Two geological Sites of Special Scientific Interest (SSSI) are identified along the coastline in the areas of possible landfall of the cable, these are:

- Site 480 –Cullen to Stake Ness Coast (NGR:NJ504675 to NJ648656): The site represents the longest continuous section across the strike of the Dalradian succession in Scotland and is considered a unique site of the very highest importance for Quaternary studies in Scotland.
- Site 1631 – Whitehills to Melrose Coast (NGR: NJ648655 to NJ745650): A key geomorphological site for its near complete structural and metamorphic transect across the Dalradian outcrop.

Reproduced with the permission of the British Geological Survey © NERC. All Rights Reserved.
 © Crown copyright and database rights [2013] Ordnance Survey [License Numbers: 1350462, 1326001, 1065958]. Contains Ordnance Survey data © Crown Copyright and database right [2014].
 Moray Offshore Renewables Ltd © 2014. This document is the property of contractors and sub-contractors and shall not be reproduced nor transmitted without prior written approval.

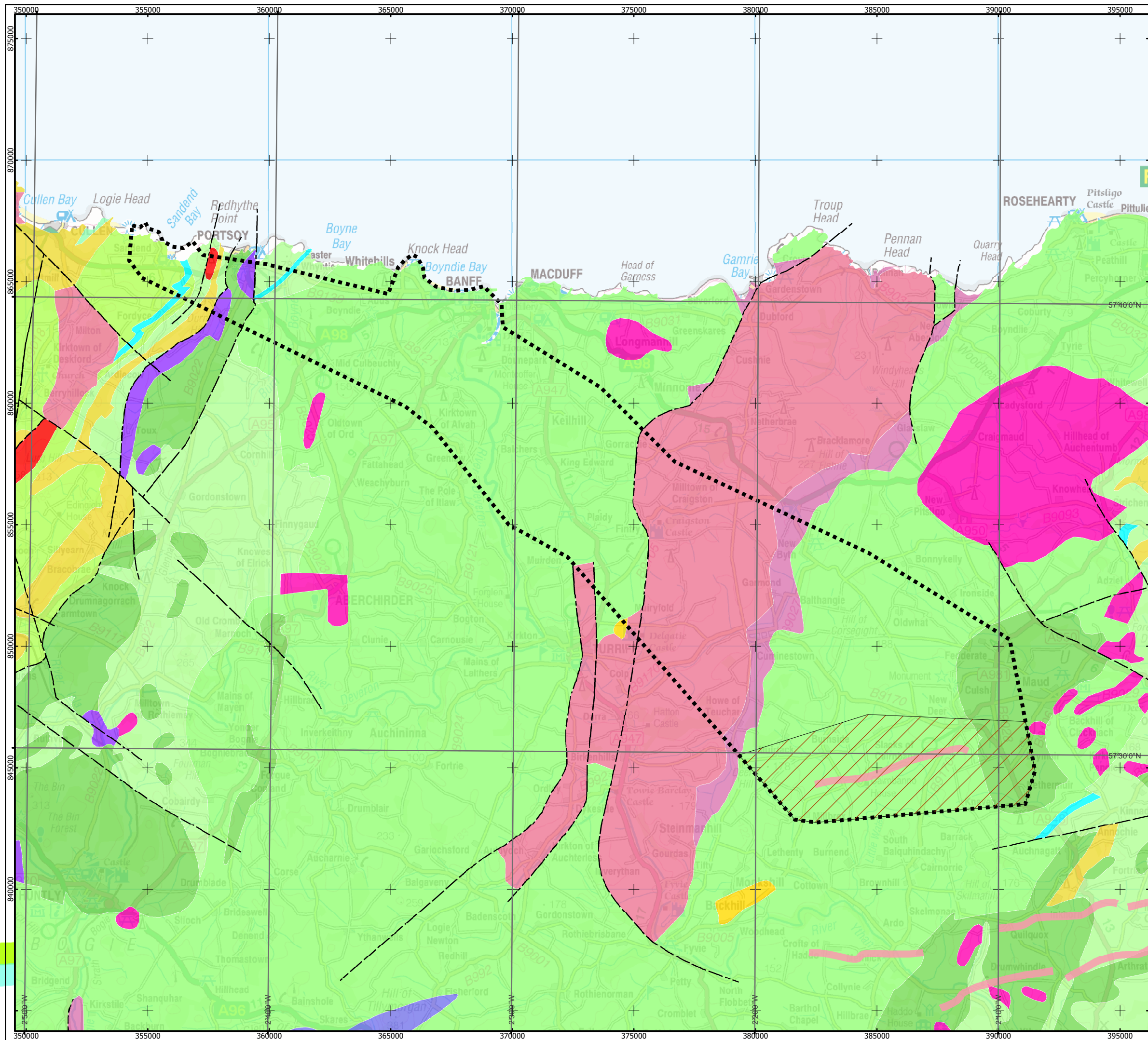

Moray Offshore Renewables Ltd

KEY

- Onshore Cable Corridor Search Area
- Onshore Substation Search Area

FAULTS

- Fault at rockhead

DYKES

- UNNAMED IGNEOUS INTRUSION, CARBONIFEROUS TO PERMIAN - DOLERITE AND THOLEIITIC BASALT

BEDROCK

- NEOGENE ROCKS (UNDIFFERENTIATED) - GRAVEL, SAND, SILT AND CLAY
- MIDDLE OLD RED SANDSTONE (UNDIFFERENTIATED) - CONGLOMERATE, SANDSTONE, SILTSTONE AND MUDSTONE
- LOWER OLD RED SANDSTONE - CONGLOMERATE, SANDSTONE, SILTSTONE AND MUDSTONE
- UNNAMED IGNEOUS INTRUSION, ORDOVICIAN TO SILURIAN - FELSIC-ROCK
- UNNAMED IGNEOUS INTRUSION, ORDOVICIAN TO SILURIAN - MAFIC IGNEOUS-ROCK
- UNNAMED IGNEOUS INTRUSION, ORDOVICIAN TO SILURIAN - ULTRAMAFITITE
- APPIN GROUP - METALIMESTONE
- APPIN GROUP - GRAPHITIC PELITE, CALCAREOUS PELITE, CALCSILICATE-ROCK AND PSAMMITE
- APPIN GROUP - QUARTZITE
- ARGYLL GROUP - METALIMESTONE
- ARGYLL GROUP - PSAMMITE, SEMIPELITE AND PELITE
- ARGYLL GROUP - QUARTZITE
- GRAMPIAN GROUP - PSAMMITE AND SEMIPELITE
- GRAMPIAN GROUP - QUARTZITE
- SOUTHERN HIGHLAND GROUP - PELITE
- SOUTHERN HIGHLAND GROUP - PSAMMITE AND PELITE
- UNNAMED IGNEOUS INTRUSION, NEOPROTEROZOIC - FELSIC-ROCK

Horizontal Scale: 1:150,000 A3 Chart

Geodetic Parameters: British National Grid	
Produced: KAG	
Reviewed: NB	
Approved: RH, SP	
Date: 31/03/2014	Revision: A
REF: 8460001-PSO0010-RPS-MAP-003	

Fig 5-5 Bedrock Geology

Moray Offshore Renewables Ltd

© Crown copyright and database rights [2013] Ordnance Survey [License Numbers: 1350462, 1326001, 1065958]. Contains Ordnance Survey data © Crown Copyright and database right [2014]. Moray Offshore Renewables Ltd © 2014. This document is the property of contractors and sub-contractors and shall not be reproduced nor transmitted without prior written approval.

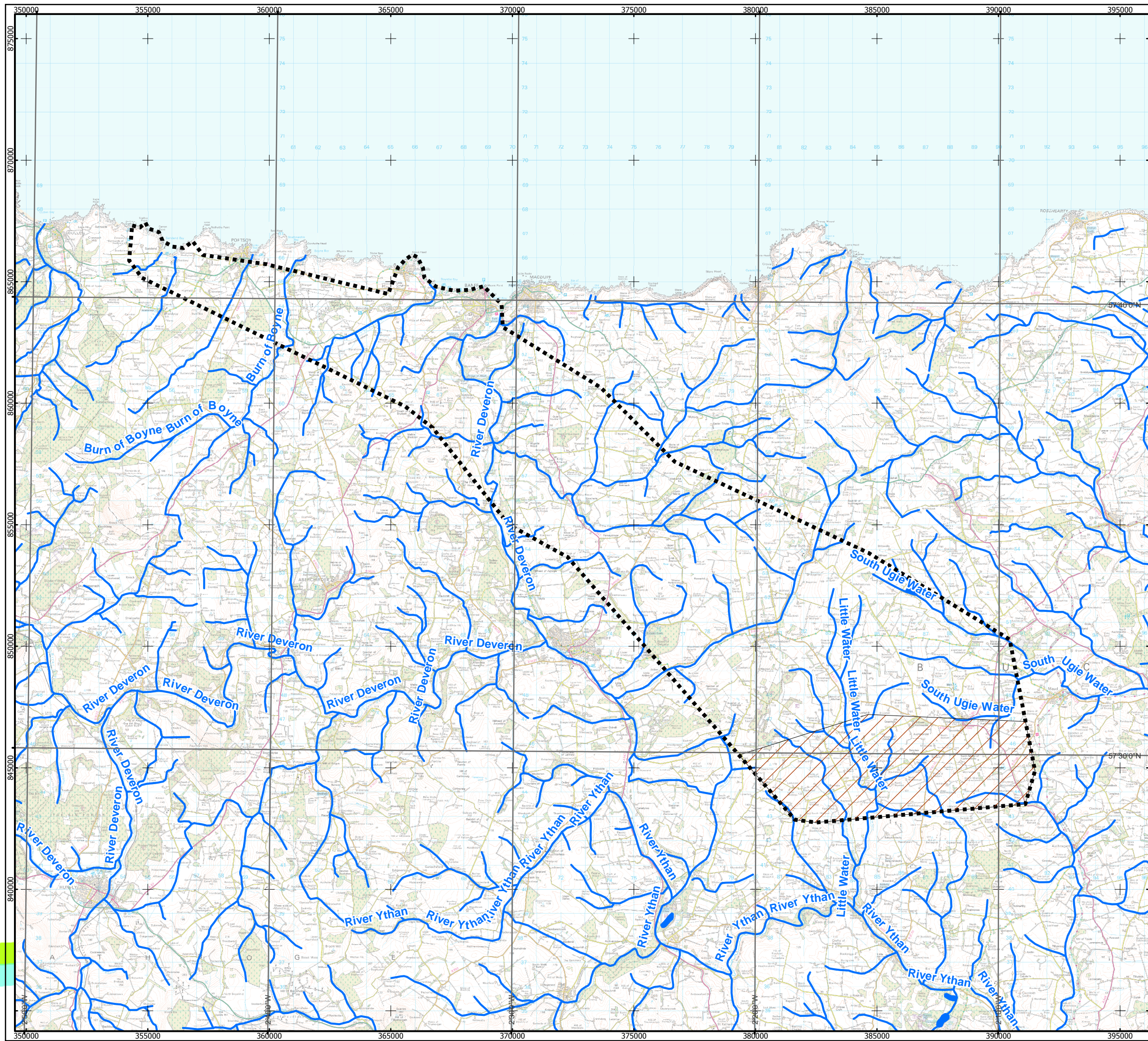

Moray Offshore Renewables Ltd

KEY

- Onshore Substation Search Area
- Onshore Cable Corridor Search Area
- Surface Water

Horizontal Scale: 1:150,000

A3 Chart

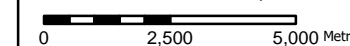

Geodetic Parameters: British National Grid

Produced: KAG
Reviewed: NB
Approved: RH, SP

Date: 02/04/2014 Revision: A

REF: 8460001-PSO0010-RPS-MAP-004

Fig 5-6 Surface Water

Moray Offshore
Renewables Ltd

Reproduced with the permission of the British Geological Survey © NERC. All Rights Reserved.
 © Crown copyright and database rights [2013] Ordnance Survey [License Numbers: 1350462, 1326001, 1065958]. Contains Ordnance Survey data © Crown Copyright and database right [2014].
 Moray Offshore Renewables Ltd © 2014. This document is the property of contractors and sub-contractors and shall not be reproduced nor transmitted without prior written approval.

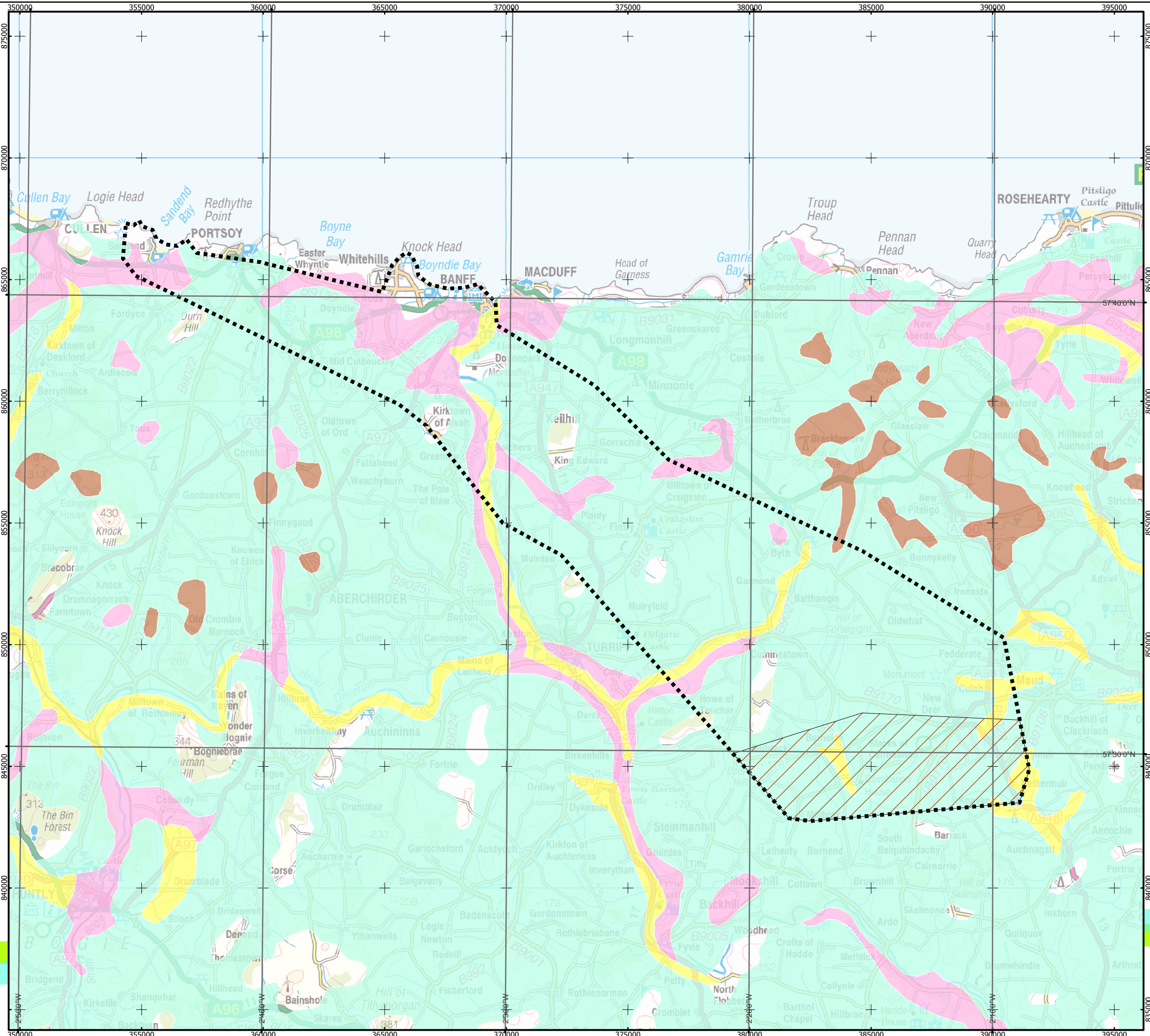

Moray Offshore Renewables Ltd

KEY

- Onshore Substation Search Area
- Onshore Cable Corridor Search Area

Superficial Geology

- ALLUVIUM
- GLACIAL SAND AND GRAVEL
- PEAT
- TILL

Horizontal Scale: 1:150,000 A3 Chart

Geodetic Parameters: British National Grid	
Produced: KAG	
Reviewed: NB	
Approved: RH, SP	
Date: 02/04/2014	Revision: A
REF: 8460001-PSO0010-RPS-MAP-002	

Fig 5-7 Superficial Geology

Moray Offshore Renewables Ltd

HYDROGEOLOGY

SEPA mapping (SEPA, 2004a) of superficial aquifers indicates varied shallow groundwater conditions along the corridor. These are dominated by low productivity intergranular flows with pockets of high productivity, but include areas (becoming more dominant to the east) of non aquifers. The bedrock aquifers (SEPA, 2004b) are dominated by fracture flow of low productivity for the main, with very low productivity where igneous intrusions prevail. Intergranular fracture flow of moderate productivity is evident in the areas of Old Red Sandstone.

The SEPA Groundwater Vulnerability Map of the Uppermost Aquifer (SEPA, 2004c) indicates that the region within which the onshore cable corridor search area is located is predominantly underlain by groundwater with a vulnerability of Class 4a (vulnerable to those pollutants not readily absorbed or transformed with clay less likely in superficial deposits), although small localised areas of Classes 4b and 5 also exist.

The onshore cable corridor search area is identified as being located within a Groundwater Body Drinking Water Protected Area as identified by Map 21 of (SEPA, 2007). Additionally, it is identified that the search area also transects a Surface Water Drinking Water Protected Area (SEPA, 2007) at the River Deveron to the south of Banff (Map 10).

HYDROLOGY

The onshore cable corridor search area is identified as being transected by various burns, streams and rivers (Figure 5-6). The River Deveron catchment (NJ 54409 43727) is the largest catchment intersected by the cable corridor search area. The main tributaries within this catchment which require crossing are the Burn of Turriff (NJ 78284 50535) and the urn of King Edward (NJ 76720 58154). Other significant watercourses within the study area are the River Ugie (NJ 82455 37528) and the River Ythan (NJ 96472 50572).

The two options for coastal landfall points of the cable are located at Sandend Bay in the West, or Boyndie Bay in the East, and of importance is the potential risk of flooding at these locations. The risk of flooding at the onshore substation locations will also be considered.

MINERAL EXTRACTION

Given the geological strata identified within the onshore cable corridor search area, no coals reserves are evident within the region; as such the potential for the sterilisation of such mineral resources is limited.

It is acknowledged that sand and gravel deposits may locally present which have the potential to be economically viable, and as such the potential effect of the development upon them will be considered further.

LAND CONTAMINATION

At present there is not sufficient information to identify if there are areas of potentially contaminated land within or adjacent to the onshore cable corridor search area.

Data Gaps

The geo-environmental baseline data presently available describing conditions underlying the onshore cable corridor search area are not of sufficient quality to support either detailed Environmental Impact Assessment or the engineering design of the OnTI. Therefore, a more detailed study will be required to provide this information. The combined data set will be used to more accurately predict the potential for effects of the OnTI on known sensitive receptors.

The studies to expand the baseline data and assess potential effects are provided in the following sections.

Environmental Impact Scoping

Based on the available literature, it is considered that the potential effects to the onshore physical environment as a result of constructing the OnTI may include:

Effect Description	Potential site specific effect	Potential cumulative and/or in-combination effect
Damage to geological features/designated sites.	✓	Unknown
Alteration/modification of the hydrological/hydrogeological regime of the region and associated receptors.	✓	Unknown
Disturbance of contaminated materials/soil gases and the subsequent generation of potentially contaminated waste materials and effect upon construction materials and workers.	✓	Unknown
Construction phase activities affecting on the Water Environment (e.g. spillages, use of chemicals, sedimentation).	✓	Unknown

Consideration of the above issues will be made with respect to the onshore cable corridor search area.

Site-specific Impact Assessment Methodology

For each of the possible effects described above, the potentially present sensitive receptors, the surveys or studies required to address outstanding data gaps and a proposed method of impact assessment are described in the tables below. In each case, a more specific list of sensitive receptors relevant to the site will need to be identified via the scoping and stakeholder feedback and agreed in advance with the regulator for consideration in the ES.

Potential Effect	Damage to geological features/designated sites during construction.
Sensitive Receptors	Potentially sensitive receptors include: <ul style="list-style-type: none"> - Geologically important formations/sites including SSSIs (Site 480 and Site 1631). - Reserves of extractable minerals/deposits.
Survey/Study Proposed to Assess Effect	To inform studies to determine the potential for effects on geological features, the following surveys and studies will be undertaken: <ul style="list-style-type: none"> - Phase I Desk Study. - Consultations with SNH and local Regionally Important Geological Sites (RIGS) groups.
Method of Impact Assessment	A more specific list of sensitive receptors will be identified for study. Historical and newly collected survey data will be collated to inform conceptual modelling which will be used in turn to determine the requirement for further investigation and/or mitigation.

Potential Effect	Alteration/modification of the hydrological/hydrogeological regime of the region, including: <ul style="list-style-type: none"> - Run-off/flow patterns and associated flooding during construction and operation. - Erosion and sedimentation of surface water courses during construction. - Contamination via the use/spillage of chemicals/fuels/oils during construction and operation.
Sensitive Receptors	Potentially sensitive receptors include: <ul style="list-style-type: none"> - Surface/groundwater bodies. - Private/public water supplies.
Survey/Study Proposed to Assess Effect	To inform studies to determine the potential for alteration of the hydrological/hydrogeological regime, the following surveys and studies will be undertaken: <ul style="list-style-type: none"> - Phase I Desk Study. - Identification of public/private water supplies. - Flood Risk Assessment (if required). - Identification of water courses, sensitivity and over-land flow paths.
Method of Impact Assessment	A more specific list of sensitive receptors will be identified for study. Historical and newly collected survey data will be collated to inform conceptual modelling which will be used in turn to determine the potential for alteration of the hydrological/hydrogeological regime.

Potential Effect	Disturbance of contaminated materials/soil gases and the subsequent generation of potentially contaminated waste materials.
Sensitive Receptors	Potentially sensitive receptors include: <ul style="list-style-type: none"> - Human health (nearby residents, users and construction workers). - The Water Environment including private/public water supplies. - Construction materials.
Survey/Study Proposed to Assess Effect	To inform studies to determine the potential for the presence of contaminated material, the following surveys and studies will be undertaken: <ul style="list-style-type: none"> - Phase I Desk Study.
Method of Impact Assessment	Desk study research will identify the presence of potentially contaminated sites (if applicable) which could affect the onshore cable route corridor search area. Based on the findings of this study, a more specific list of sensitive receptors will be identified for impact assessment. Historical and newly collected survey data will be collated to inform conceptual modelling which will in turn be used to inform the requirement for further investigation and/or risk assessment and mitigation.

Potential Effect	Construction phase activities, including: <ul style="list-style-type: none"> - Material excavation/foundation construction. - Erosion and sedimentation of surface watercourses as a result of the construction of substation and activities associated with cable burial. - Contamination via the use/spillage of chemicals/fuels/oils.
Sensitive Receptors	Potentially sensitive receptors include: <ul style="list-style-type: none"> - The Water Environment including private/public water supplies. - Human health (nearby site residents, site users and construction workers).
Survey/Study Proposed to Assess Effect	To inform studies to determine the potential for effect from specific construction activities, the following surveys and studies will be undertaken: <ul style="list-style-type: none"> - Phase I Desk Study. - Hydrological studies including identification of watercourses, flow paths, flood risk, identification of water supplies, water quality and river sensitivity.
Method of Impact Assessment	A more specific list of sensitive receptors will be identified for study. Historical and newly collected survey data will be collated to inform conceptual modelling which will be used in turn to inform the development of the construction management plan and route selection.

Cumulative and In-combination Impact Assessment

The desk research would consider other development activities in proximity to the onshore cable corridor search area once identified, or proposed changes at land surrounding the substation search area that could result in cumulative or in-contribution effects.

Site Specific Survey Methodology

BEST PRACTICE GUIDANCE

- A Handbook on Environmental Impact Assessment, (Scottish Natural Heritage (SNH) 2005).
- Assigning groundwater assessment criteria for pollutant inputs, WAT-PS_10_01 SEPA V2.1. June 2011.
- CIRIA (2005). Construction Industry Research and Information Association (CIRIA) (2005): C650: Environmental Good Practice on Site.
- CIRIA C502 Environmental Good Practice on Site.
- CIRIA C515 Groundwater Control - Design and Practice.
- CIRIA C521 Sustainable Urban Drainage Systems Design Manual for Scotland and England.
- CIRIA C532 Control of Water Pollution from Construction Sites.
- CIRIA 552: Contaminated Land Risk Assessment – A Guide to Good Practice (CIRIA 2001).
- CIRIA C648 Control of Water Pollution from Linear Construction Projects.
- CIRIA C650 Environmental Good Practice on Site (Expansion of C502).
- CIRIA C665 Assessing Risks Posed by Hazardous Ground Gases to Buildings, 2006.
- CIRIA C682: The VOCs Handbook. Investigating, assessing and managing risks from inhalation of VOCs at land affected by contamination. CIRIA 2009.
- CIRIA C689 Culvert Design and Operation Guide.
- Code of Practice for Site Investigations, British Standards Institute BS 5930, Amendment 2, 2010).
- Construction (Design and Management) Regulations (CDM) (2007). Office of Public Sector Information (OPSI).
- User Guide; Groundwater Vulnerability (Scotland) GIS Dataset, Version 2, BGS, 2011.
- Design Manual for Roads and Bridges, Volume 11.
- River Basin Management Plan for the Scotland River Basin District, SEPA.
- EIA (Scotland) Regulations 1999.

- Engineering in the Water Environment, Good Practice Guide, Temporary Construction Methods, 1st Edition, SEPA, March 2009.
- Engineering in the Water Environment, Good Practice Guide, Construction of River Crossings, 1st Edition, SEPA, April 2008.
- Environmental Protection Act 1990: Part IIA Contaminated Land Statutory Guidance: Edition 2, Scottish Executive, May 2006, Paper SE/2006/44.
- Guidelines for Environmental Impact Assessment (Institute of Environmental Management and Assessment 2004, updated 2005 and 2006).
- Investigation of potentially contaminated sites, code of practice, British Standards Institute, BS 10175: 2011.
- Managing River Habitats for Fisheries, SEPA, 2002.
- Methodology for the Water Framework Directive, SNIFFER, Project WFD 28 Final Report 2004.
- No.19 Groundwater Protection Policy for Scotland.
- Planning Advice Notes.
- Planning Advice Note 33: Development on Contaminated Land, Scottish Executive, October 2000.
- PPG1 General Guide to the Prevention of Water Pollution.
- PPG2 Above Ground Oil Storage Tanks.
- PPG5 Works in, Near or Liable to Affect Watercourses.
- PPG6 Working at Construction and Demolition Sites.
- PPG8 Safe Storage and Disposal of Used Oil.
- PPG21 Polluting Incident Response Planning.
- Pollution Prevention and Control (Scotland) Regulations 2000 – PPC Technical Guidance Note 2, Content and Scope of Site Reports; SEPA; June 2006.
- Private Water Supplies: Technical Manual, Scottish Executive, 2006.
- Protection of Workers and the General Public during the Development of Contaminated Land (HSE 19991).
- PS-06-02 Culverting of Watercourses.
- River Crossings and Migratory Fish: Design Guidance, A Consultation Paper, The Scottish Executive.
- Scottish Planning Policy (February 2010) - replacing (SPP) 6 Renewable Energy (2007).
- Scottish Planning Series Planning Circular 8-2007: The Environmental Impact Assessment (Scotland) Regulations 1999, Scottish Executive.
- SNH: A Handbook on Environmental Impact Assessment. 2006.
- Special Requirements for Civil Engineering Contracts for the Prevention of Pollution, Version 2, SEPA, 2006.
- Supporting Guidance, Environmental Standards for Discharges to Surface Waters, WAT-SG-53, SEPA V3.1, August 2010.
- The National Waste Strategy 1999.
- The Water Environment (Controlled Activities) Regulations (Scotland) 2005. Office of Public Sector Information (OPSI).
- Town and Country Planning (Environmental Impact Assessment) (Scotland) Regulations 2011.
- UK Technical Advisory Group on the WFD, UK Environmental Standards and Conditions (Phase 2), Final, March 2008.
- Water Environment and Water Services (Scotland) Act 2003.
- Water pollution arising from land containing chemical contaminants, SEPA Edition 2, 2009.

Summary of Methodology

PHASE I DESK STUDY

A Phase I desk-based assessment, complimented by a site visit will be completed to establish all baseline information pertaining to the geological, hydrological, hydrogeological and any contaminated land conditions within the onshore cable corridor search area and will consider the degree to which the underlying ground has been contaminated by historic or current uses. This will highlight potential risks to human health and the wider environment as a result of activities associated with the cable burial and onshore substation construction (including maintenance/repair activities and decommissioning).

The assessment will follow a phased approach to determine the nature of any potential effect on the onshore cable corridor search area, landfall points and substation locations (when selected), and will include:

- Identification of current guidance, standards and methodologies for establishing baseline geological, hydrogeological, hydrological and contamination characteristics;
- Collation of information associated with existing ground conditions within the cable corridor search area and the immediate surrounding landscape through the study of previous investigations, published maps and data (including work undertaken on behalf of the local authority and others), and liaison with the landowners/managers and regulatory bodies within the cable corridor search area. Any available existing reports/data sources affecting the area will be reviewed and their adequacy for the purpose of the planning application will be determined. Any gaps in the information should be identified, especially where potential sources of contamination on adjacent land are suspected;
- Consultation with stakeholders to determine potential effects and conflicts and to agree appropriate mitigation measures;
- Creation of a conceptual model of the site to identify any existing or future potential source-pathway-receptor linkages and evaluation of their significance;
- Production of a report describing the conclusions of this stage of the work, including a description of the historic and current uses along and adjacent to the cable corridor search area, and the geological, hydrological and hydrogeological condition of the site, recommendations for intrusive site surveys/risk assessments that may be required to further enhance the understanding of underlying soils, the groundwater regime, soils gases, ground and surface water quality, or to target potential contaminated areas highlighted by the desk study and the proposed approach to the impact assessment phase.

The scope of any site investigations or risk assessments should be discussed and agreed with SEPA and the local Environment Health Officer (EHO) at Aberdeenshire Council.

HYDROLOGY STUDIES

An extensive desk study will be undertaken to establish the baseline hydrological conditions within the cable corridor search area, at the substations and landfall point once selected. The aim of this study is to identify:

- The location of all watercourses which requires crossing using OS VectorMap District vector mapping data
- Overland flow paths within the cable corridor search area and construction locations using NextMap digital terrain model data
- Flood risk from rivers and coastal waters using SEPA's Indicative River & Coastal Flood Maps
- Location and nature of water abstractions including public and private water supplies from SEPA and Aberdeenshire Council data
- Existing water quality and sensitivity of rivers using SEPA's Water Framework Directive classifications
- Groundwater vulnerability using SEPA's Digital Groundwater Vulnerability Map, Digital Aquifer Map of Scotland and Groundwater Body Information Sheet
- Location of nature conservation areas and reason for designation using SNH datasets

As part of the research, consultation will be made with SEPA, Aberdeenshire Council and Scottish Water to identify any specific requirements and collect any other available data.

Potential Mitigation Methods

Potential mitigation measures for associated effects on the onshore physical environment include:

- Route selection to avoid features and sensitive receptors (e.g. geologically designated sites).
- Adoption of location specific installation techniques.
- Buffer zones around water courses and other sensitive hydrological features.

- Effective management and control of each phase of the development to mitigate effects (e.g. by following pollution prevention guidance notes, site waste management plans, use of personal protective equipment to mitigate health effects on construction workers).
- Environmental monitoring during construction.
- Choice of construction materials/design to accommodate risks from contamination.

Additionally, the development of the construction management plan should take account of potential effects as a result of ground disturbance; for example, avoidance of sensitive geological receptors.

The mitigation measures proposed for the final OnTI will be dependent upon the final route and design and the potential effects as determined by the EIA studies. Options of mitigation will be discussed with the relevant authorities as necessary.

5.1.7 Airborne Noise and Vibration

This section considers the content and extent of the assessment of environmental airborne noise and groundborne vibration which will be covered in the Onshore Noise and Vibration ES Chapter to accompany the planning application for the OnTI. For brevity, the term 'noise' shall be taken to mean environmental airborne noise and groundborne vibration and is defined as in Article 3 of the Environmental Noise Directive (END), which states:

“environmental noise’ shall mean unwanted or harmful outdoor sound created by human activities, including noise emitted by means of transport, road traffic, rail traffic, air traffic, and from sites of industrial activity such as those defined in Annex I to Council Directive 96/61/EC of 24 September 1996 concerning integrated pollution prevention and control.”

It is convenient for noise assessments to use the word 'immission'. Whilst not in the Oxford English Dictionary, it has been in use by acousticians; British, European and International Standards committees; and the World Health Organisation (WHO) for several decades. 'Immission' is the correlative of 'emission'. Immission describes the noise received by Noise Sensitive Receptors (NSRs) whilst emission describes the noise leaving a source.

The potentially most significant noise effect associated with the project is airborne noise immissions on nearby residential NSRs from the operational substation. This is because that effect is the introduction of a long term or permanent noise source that is of a different character to the environmental noise sources present within the baseline soundscape at NSRs in the environs of the substations sites. On the basis that the level of detail provided in an EIA should be proportionate to the likelihood of a significant effect, the focus of the noise assessment will be airborne noise from the operational substations.

In contrast, whilst noise immissions from construction are likely to be relatively high if undertaken close to NSRs, these effects are temporary; occurring generally during the daytime only; and not substantially dissimilar to baseline noise sources. Groundborne vibration emissions from the majority of construction activities are typically below background levels within no more than a few tens of metres from a construction site. On this basis, the assessment of construction vibration should be limited to consideration of items of plant and activities likely to generate significant vibration. There are no groundborne vibration emissions from the operational substations or onshore export cable and hence operational vibration is scoped out of the assessment.

With reference to the END definition of environmental noise, immissions from the construction and operation of the project are unlikely to be of magnitudes at which noise is harmful. However, there is the potential for noise to be at a level that would be considered 'unwanted'. The purpose of the Onshore Noise ES Chapter will be to determine the likely significance of such effects.

Baseline Environment

PRE-EXISTING NOISE CLIMATE

Ambient soundscapes are temporally, spatially and spectrally variable. Sound levels are influenced by varying contributions from environmental noise (from transportation and industry) and natural sound; primarily from meteorological sources such as wind and rain but also birds, particularly in spring when the dawn chorus can significantly elevate baseline sound levels in rural areas in the early morning when otherwise baseline sound levels would be low. Environmental noise commonly follows diurnal and weekly patterns based on known behavioural patterns (e.g. drive to work before 09:00 hours; drive from work after 17:30 hours; go to the shops on Saturday and Sunday but generally not too early in the morning; noise generated during the night-time is generally significantly less than that generated daytime except for power stations, industrial facilities and motorways). Rural areas can also exhibit seasonal variation that follow the agricultural calendar and are due to increased vehicle movements and mechanised activities on the land (e.g. harvest time; grain drying; ploughing etc).

The areas around the potential landfall points, onshore cable corridor search and substations are predominantly rural. There are no airports, power stations or motorways in the area of the NSRs potentially affected by noise from the construction or operation of the project. Major ('A') roads are typically not dual carriageways. On this basis, the most significant source of environmental noise will be from road traffic; the temporal, spatial and spectral characteristics of which will be influenced by the type of road (major or minor); typical traffic speeds and vehicle composition (proportion of heavy vehicles).

The soundscape will be typical of rural areas and, at the landfall sites, of rural coastal areas. Baseline environmental noise levels are likely to be low during the daytime and very low during the night-time and at all times at locations distant (more than a few hundred metres) from major roads. Natural sound from wind, rain and, at coastal locations, surf will influence the ambient sound levels.

The baseline ambient and background sound levels are used in British Standard (BS) methodologies for the assessment of noise from construction sites and sources of noise that are of an industrial nature, which includes the substation. The magnitude of effects from the project will be determined on the basis of BS guidance.

CONSTRUCTION NOISE

The example methodologies for the assessment of construction noise provided in BS 5228-1 'Code of practice for noise and vibration control on construction and open sites, Part 1: Noise' include lower thresholds below which an effect is deemed to be not significant. These apply when baseline ambient sound levels are relatively low. On the basis of the above, when baseline ambient sound levels will be low and, therefore, these lower thresholds will apply.

A review of ordnance survey maps has been undertaken in order to identify NSRs and possible areas of noise sensitivity. At the landfall sites, NSRs include residential areas, holiday accommodation, caravan and camping sites, and the recreational areas of the beach and surrounding countryside. NSRs within the onshore cable corridor search area comprise various residential areas including villages, hamlets individual houses and farm houses.

As well as at the landfall point, the onshore cable corridor search area includes several river and road crossings that may require Horizontal Directional Drilling (HDD). These include the River Deveron, A98, A97, A947, A981, A948. Whilst no NSRs have been identified at these locations that are of greater sensitivity than the cable route in general, HDD works may require 24-hour working whilst the majority of cable trenching and laying activities are typically only undertaken during the daytime. 24-hour working at HDD sites is usually an operational requirement to prevent the drill from sticking in the bore.

OPERATIONAL SUBSTATION NOISE

The exact onshore substation locations are currently unknown but potential locations near New Deer have been identified and are at an early stage of assessment (see section 2 (Project Description)). All are in rural locations that are relatively sparsely populated by farms and individual houses.

One under consideration is in proximity to the A948, traffic flows are expected to be relatively low such that road traffic noise will not be particularly high at NSRs potentially affected by noise from the substations. It is also relevant to note that the assessment methodology contained within BS 4142 'Method for Rating industrial noise affecting mixed residential and industrial areas' considers the baseline environment in terms of the L_{A90} index, which is the noise level exceeded for 90% of the time. Therefore, the L_{A90} describes the underlying noise level in-between noisier events. For example, at Location 3, the L_{A90} is likely to characterise the quieter noise level in between car pass-bys and, consequently may be relatively unaffected by road traffic noise from the A948, depending upon the traffic flows.

Notwithstanding the above, no significant sources of night-time environmental noise have been identified. On this basis, night-time background noise levels are likely to be very low and, on the basis that noise from the substations will be controlled such that immissions at NSRs are similarly very low; the assessment methodology contained within BS 4142 will not be suitable. In such circumstances, it is generally accepted that other appropriate criteria should be adopted for assessing sleep disturbance during night-time periods, such as those contained within BS 8233.

Noise emission from substations is typically dominated by low-frequency signals. Transformers typically 'hum' at 100 Hz; reactors 'fizz' at 100 Hz and harmonics (i.e. 200 Hz, 400 Hz etc) thereof. However, noise propagation is frequency dependent such that the spectral content of the immissions does not necessarily match the spectral content of the emissions. The extent to which the noise immissions from the substations are perceived as a tonal humming sound, which is recognised by BS 4142 as being more likely to give rise to complaint than a non-tonal or broadband sound, depends upon the frequency content of the immissions in the context of the frequency content of the baseline background sound levels. In the absence of significant environmental noise sources in the area, there is unlikely to be significant low-frequency baseline sound. However, wind induced sound is broadband and contains some low-frequency sound that may, to a certain extent, affect the extent to which the noise from the substations is perceived as a distinguishable hum.

On this basis, robust determination of the temporal and spectral characteristics of the baseline background noise level in the context of prevailing weather conditions will be necessary to robustly describe the likely noise effects at NSRs around the substation sites. It is considered that baseline background sound levels will be spatially invariant.

Data Gaps

There are no detailed measurements of background noise currently available within the onshore cable corridor search area or substation sites. However, fixed thresholds contained within the example methodologies in BS 5228-1 for the assessment of construction noise are likely to apply at NSRs potentially affected by noise from during the construction of the landfall and onshore export cable on the presumption that the baseline noise environment at these locations is quiet and commensurate with a rural area. On this basis, it should not be necessary to undertake detailed baseline noise surveying at the landfall sites and within the onshore cable corridor search area.

As described above, robust determination of the baseline background noise levels at NSRs around the substation site will be required. Detailed baseline long term surveys over a continuous period of three weeks will be undertaken at key locations around each substation site that are representative of the baseline noise environment at all potentially affected NSRs. The surveys will include measurements of the spectral soundscape and simultaneously measure local wind and rain conditions so that the influence of sound from these sources can be taken into account.

It will be necessary for the prediction of noise from the substation to robustly consider the likely spectral noise emissions from typical substation equipment so that the tonal character (i.e. the extent to which it is perceived as a 'hum') can be described.

Environmental Impact Scoping

Based on the available literature, it is considered that the potential effects on sensitive receptors as a result of constructing and operating the OnTI may include:

Effect Description	Potential site specific effect	Potential cumulative and/or in-combination effect
Addition of noise as a result of construction work within the onshore cable corridor search area and substation sites	✓	✓
Addition of vibration as a result of construction work within the onshore cable corridor search area and substation sites	✗	✗
Increase in noise from traffic along local roads as a result of construction works	✓	✓
Increase in vibration from traffic along local roads as a result of construction works	✗	✗
Addition of noise as a result of operational substations	✓	✓
Addition of noise as a result of maintenance works (substations and onshore export cable)	✗	✗
Adverse comment from occupants of residential areas from vibration as a result of operation (substation) and maintenance works (substations and onshore export cable)	✗	✗

Impact Assessment Methodology

For each of the potential effects described above a survey or study and method of impact assessment is described in the tables below. The likely significance of effects will be determined by correlating the magnitude of the effect to the sensitivity of the receptor. The sensitivity of a receptor considers the susceptibility of people or operations to be disturbed by noise based on the use of the receptor.

Potential Effect	Addition of noise as a result of construction work within the onshore cable corridor search area and substation sites. Increase in noise from traffic along local roads as a result of construction works.
Study Proposed to Assess Effect	A desk-based model of likely ranges at which various magnitudes of significant effect would occur on the basis of BS source term data and prediction methodology.
Method of Impact Assessment	A desk-based assessment using the results of modelling, BS guidance and an assessment of the sensitivity of NSRs will be used to assess the potential effects of noise on human receptors for the cable landfall points, the onshore export cable, construction of the substations and in respect of increased traffic where relevant.

Potential Effect	Addition of noise as a result of operational substation.
Survey/Study Proposed to Assess Effect	Baseline noise surveys to quantify the baseline soundscapes at selected representative stations, to be agreed between MORL and the local authority. The surveys will comprise detailed measurements representative of NSRs potentially affected by noise from the substation and will take into account prevailing local weather conditions. A desk-based model of the likely noise emissions from the substation that takes into account the spectral content of emissions.
Method of Impact Assessment	A desk-based assessment using the results of modelling, Scottish Government and BS guidance and an assessment of the sensitivity of NSRs will be used to assess the potential effects of noise on human receptors from the operational substations. The assessment will consider the tonal content of noise immissions in the context of the baseline soundscape of the area.

Site-Specific Survey Methodology

BEST PRACTICE GUIDANCE

The assessment of environmental noise and vibration will be undertaken with reference to published guidance including:

- Planning Advice Note 1 (PAN 1) "Noise" (2011)
- Technical Advice Note (TAN 11) "Assessment of Noise" (2011)
- BS 7445 "Description and measurement of environmental noise" (2003, 1991 & 1991)
- BS 4142 " Method for Rating industrial noise affecting mixed residential and industrial areas" (1997)(currently being revised)
- BS 5228 "Code of practice for noise and vibration control on construction and open sites" (2014)
- BS 8233 "Sound insulation and noise reduction for buildings" (1999) (currently being revised)

Prior to work being undertaken, consultation will be made with the Aberdeenshire Council Health and Environmental Service to agree the scope and methodology and assessment, and locations at which detailed noise surveys will be undertaken.

Baseline noise surveys will be undertaken to record the noise at the selected representative stations, to be agreed between MORL and the local authority. It is likely that the survey will comprise long-term surveys over a continuous period of three weeks at key locations within the substation search area that are representative of the baseline noise environment at all potentially affected NSRs. The surveys will include measurements of the spectral soundscape and simultaneously measure local wind and rain conditions so that the influence of sound from these sources can be taken into account.

ONSHORE CABLE CORRIDOR SEARCH AREA AND LANDFALL

A desk-based assessment will be used to assess the potential effects of noise on human receptors for the cable landfall points, the cable corridor search area, the construction of the substation, and in respect of increased traffic where relevant. The desk-based assessment will identify the significance of noise and vibration along the landfall within the cable corridor search area using the results of modelling, BS guidance and an assessment of the sensitivity of NSRs.

SUBSTATION SITES

The desk study will be undertaken to provide a first-cut evaluation of the likely effect of noise from the operation at the substation sites. If required as a result of this study, the existing noise conditions at the site will be documented by means of an acoustic survey, which will measure the noise level in the vicinity of the NSRs at the substation sites. The survey will comprise long-term measurements of day and night time noise levels over a period of approximately 3 weeks, and will be carried out in accordance with current best practice guidance, including that contained within BS 7445 and BS 4142. The methodology and monitoring points will be

agreed with the appropriate authorities prior to the work being taken. This will form the basis for further assessment if required.

If required, following the preceding survey, detailed modelling will be undertaken to evaluate the likely noise immissions at NSRs from the operation of the onshore substations. The study will determine the significance of the effects of noise on human receptors. The modelling will focus on the effects of noise on local properties and is anticipated to include consideration of the effects of low frequency tonal noise and hum associated with the operation of the transformers and reactors; and broadband noise associated with cooling fans. The assessment will be based upon the methodology contained within BS 4142 and, where baseline and immission levels are very low such that the methodology contained within BS 4142 is not suitable, BS 8233; and Scottish Government guidance contained within PAN 1 and TANAN 11.

The assessment will follow standard methods to describe qualitatively any effect magnitude and significance, and will be supported by quantitative assessments as required to establish conformity with any noise limits agreed for the project.

Cumulative and In-Combination Impact Assessment & Survey Methodologies

The methodologies and potential survey requirements by which cumulative and in-combination effects will be assessed will be agreed with relevant consultees.

Potential Mitigation methods

Potential mitigation associated with the construction works along within the onshore cable corridor search area and substation sites, may best be achieved through the use of suitable best practice and the agreement of working times to minimise the effect on local communities and critical locations. This may involve controls on the construction activities, including restrictions on hours of work and the use of quiet machinery and construction techniques. In all cases noise disturbance will be minimised using the concept of best available technique.

Potential mitigation with regards to operational noise from the substations may involve the selection of quieter plant, use of noise enclosures and/or noise barriers, the effectiveness of which will be demonstrated by detailed noise modelling.

5.2 Biological Environment

5.2.1 Data Sources

The following data sources provide information on the existing biological environment at the current time:

-
- Marine Scotland
- UK Offshore Energy Strategic Environmental Assessment, DECC
- SEA 5: Strategic Environmental Assessment of parts of the northern and central North Sea to the east of the Scottish mainland, Orkney and Shetland, DTI
- Strategic Environmental Assessment (SEA) of Draft Plan for Offshore Wind Energy in Scottish Territorial Waters: Volume 1 Environmental Report (Scottish Government)
- MORL ES (2012)
- Scottish Natural Heritage (SNH)
- Joint Nature Conservation Council (JNCC)

5.2.2 Benthic Ecology

Baseline Environment

Benthic studies within the Moray Firth have largely focused on the Smith Bank and the Beatrice Field (Eleftheriou *et al*, 2004). The greater part of the Moray Firth and that area relevant to the offshore cable route corridor remains almost entirely unstudied in this context. Broad scale mapping of predictive EUNIS seabed habitats (Figure 5-8) indicates that the current scoping area coincides with circalittoral sand with some circalittoral and circalittoral / infralittoral coarse sediment particularly in inshore areas.

Survey data from SEA 5 for the outer Moray Firth (DTI, 2004) indicated that sediments were variable, ranging from generally coarse sediment cover to muddy, very fine to fine sands becoming finer with depth. This distribution pattern was broadly confirmed following recent site specific EIA investigative surveys within the MORL OGS and Beatrice proposed turbine arrays (MORL ES, 2012 and BOWL ES, 2012). These surveys showed that the circalittoral fine sand sediments were characterised by a typical sand fauna including the polychaetes *Spiophanes bombyx*, *Ophelia borealis*, *Poecilochaetus serpens* and *Owenia fusiformis*, the bivalve molluscs *Cochlodesma praetenu* and *Crenella decussata* and the urchin *Echinocyamus pusillus*. Coarser sand sediments were characterised by a comparatively richer and more diverse fauna typified by the polychaetes *Chone* sp., *Notomastus* sp., *Lumbrineris gracilis*, *Aonides paucibranchiata* and *Glycera lapidum*, the pea urchin *E. pusillus*, the amphipod *Atylus vedlomensis* and ribbon worms Nemertea. Very coarse gravel substrates were also found as isolated patches but were generally not amenable to grab sampling techniques. These habitat types were characterised by seabed video which showed an associated epifauna comprising the urchin *Echinus esculentus*, encrusting worms *Pomatoceros* sp. and *Hydroides* sp. the squat lobster *Munida rugosa* common starfish *Asterias rubens* and sparse bryozoan and hydroid turfs.

In the nearshore environment, the habitats are predominately infralittoral coarse sediments (coarse sand, gravelly sand, shingle and gravel) and circalittoral coarse sediments (coarse sands and gravel or shell). Both habitat types are usually characterised by robust bivalve and polychaete species. The horse mussel (*Modiolus modiolus*) is associated with circalittoral coarse sediment (JNCC, 2011) and is common throughout the inner Moray Firth (UK BAP, 2010). However, there are no known areas of *Modiolus* reef (an Annex I habitat) in the vicinity of the offshore cable route study area. The fan mussel *Atrina fragilis* is also known to occur in the Moray Firth (UK BAP, 2010). The fan mussel is protected under Schedule 5 of the Wildlife and Countryside Act 1981 and is listed on the UK Biodiversity Action Plan. There are currently no records of the fan mussel within the vicinity of the proposed offshore cable route study area.

With regard to characterising epibenthos, Calloway *et al*. 2002 identified a northern North Sea assemblage which occurred between 50-100 m (within which the current scoping area was found). The characterising

species were whelks such as *Neptunea antiqua* and *Colus gracilis*, the hermit crabs *Pagurus pubescens* and *Anapagurus laevis* as well as other species such as *Hydroides norvegica*, *Hyas coarctatus*, *Flustra foliacea* and *Epizoanthus papillosus*. Jennings *et al.* (1999) identified some similar species as well as *Asterias rubens*, *Crangon allmani* and *Astropecten irregularis*. Attached species accounting for similarity within the northern North Sea cluster were the hydroids *Flustra foliacea*, *Hydrallmania falcata*, *Lafoea dumosa*, the sponge *Suberites ficus*, the sea-squirt *Ciona intestinalis* and the bryozoan *Alcyonidium diaphanum* (Jennings *et al.* 1999).

The current ESs for both the BOWL and MORL offshore wind farms describe medium sand sediments located on the Smith Bank and at the northernmost extents of the respective proposed export cable corridors. Benthic communities were generally characterised by polychaete worms (e.g. *S. bombyx*, *Notomastus spp.*, *Lumbrineris gracilis* and *Chone sp.*), the burrowing urchin (*Echinocyamus pusillus*) and the bivalve *Cochlodesma praetenuae*. Sessile epifauna included the calcareous tube dwelling keel worm (*Pomatoceros triqueter*), soft corals, barnacles, sea fans (hydroids) and sea mats (bryozoans). South of the Smith Bank and throughout the majority of the length of the BOWL cable corridor to Portgordon, video surveillance recorded a predominantly muddy sand and mud seabed habitat. This habitat showed evidence of bioturbation including burrows and mounds. Typical species included seapens, such as *Pennatula phosphorea* and the burrowing prawn *Nephrops norvegicus*. This habitat was consistent with the Scottish draft list “burrowed mud” Priority Marine Feature (PMF).

Approaching the landfall of the proposed BOWL export cables, which are located to the west of the proposed Sandend landfall point, the seabed comprised fine to medium sands and gravels together with coarser, more mixed cobble, pebble and gravel substrates supporting a characteristic encrusting fauna such as tubeworms, barnacles, bryozoans, algae and hydroids. Areas of dense cobbles resembled Annex I cobble reef. Offshore of the previously proposed MORL cable landfall site at Fraserburgh, outcropping bedrock with dense soft corals, kelps and red algae together with areas of encrusting *Sabellaria spinulosa* communities resembling Annex I *Sabellaria* reef habitat were recorded.

Intertidal sediment habitats at the cable landfall sites included well sorted clean sands characterised by a naturally impoverished infauna due to the dynamic nature of the environment and associated substrate mobility.

Contains EUNIS Habitat Layer © UKSeaMap 2014. Moray Offshore Renewables Ltd © 2014. This document is the property of contractors and sub-contractors and shall not be reproduced nor transmitted without prior written approval.

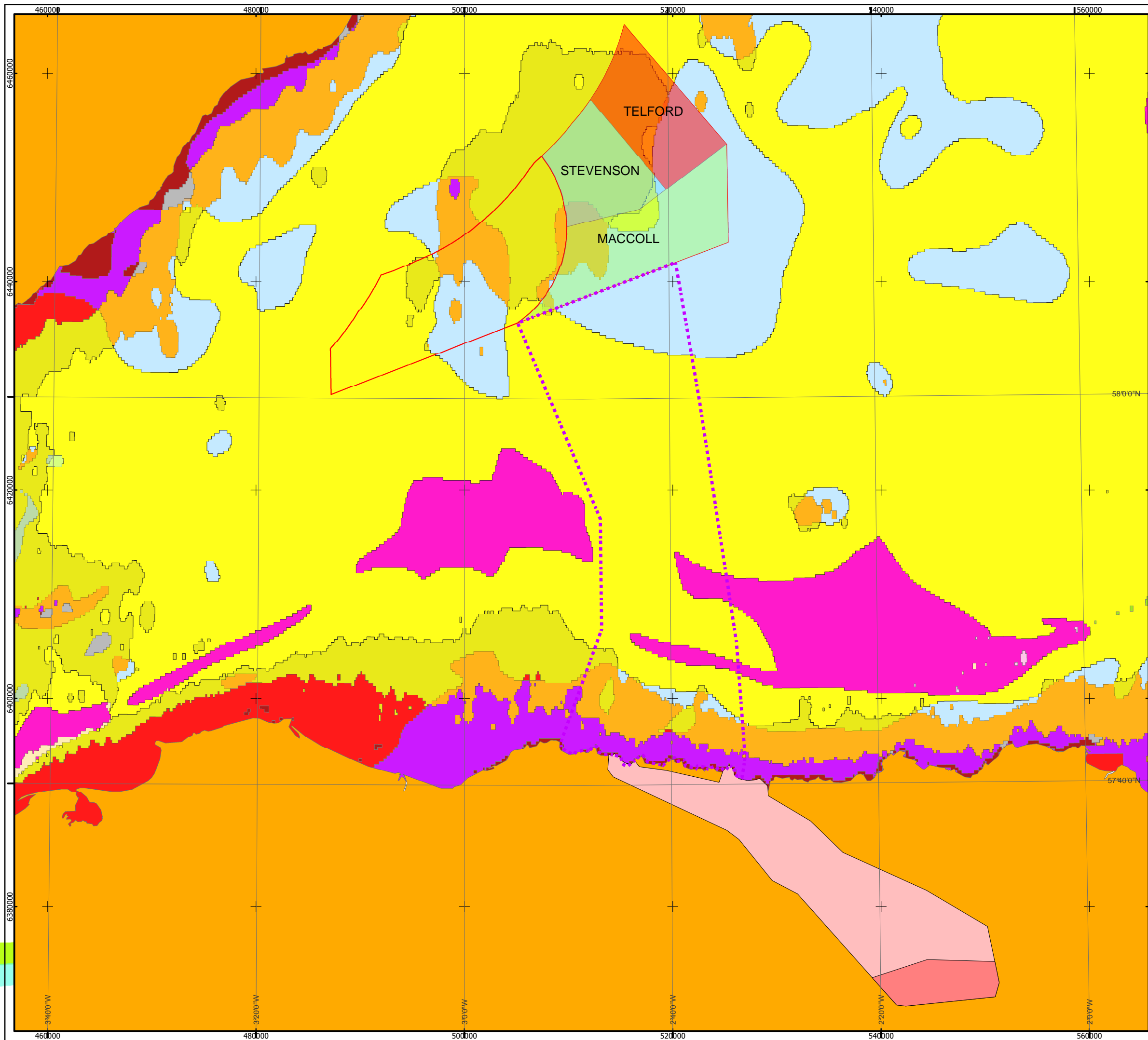

Moray Offshore Renewables Ltd

KEY

- Offshore Cable Corridor
- Onshore Substation Search Area
- Onshore Cable Corridor Search Area
- The Zone
- EUNIS 2007-11 Predicted Habitats**
- Circalittoral coarse sediment
- Circalittoral fine sand or circalittoral muddy sand
- Circalittoral mixed sediments
- Circalittoral sandy mud or circalittoral fine mud
- Deep circalittoral coarse sediment
- Deep circalittoral mixed sediments
- Deep circalittoral mud
- Deep circalittoral sand
- Deep-sea mud
- Deep-sea sand or deep-sea muddy sand
- Faunal communities on deep low energy circalittoral rock
- Infralittoral coarse sediment
- Infralittoral fine sand or infralittoral muddy sand
- Low energy circalittoral rock
- Low energy infralittoral rock

Horizontal Scale: 1:350,000

A3 Chart

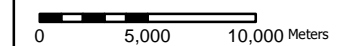

Geodetic Parameters: WGS84 UTM Zone 30N

Produced: RH
Reviewed: PM
Approved: SP

Date: 07/04/2014 Revision: B

REF: 8460001-PSO0010-MOR-MAP-039

Fig 5-8 Predicted EUNIS Seabed Habitats

Moray Offshore Renewables Ltd

FEATURES OF NATURE CONSERVATION INTEREST

There are three species on the current Scottish draft PMF list which have potential to occur within the current scoped area. These include the European spiny lobster *Palinurus elephas*, the Ocean quahog *Arctica islandica* (both species PMFs) and the mud burrowing amphipod *Maera loveni* (Figure 5-9).

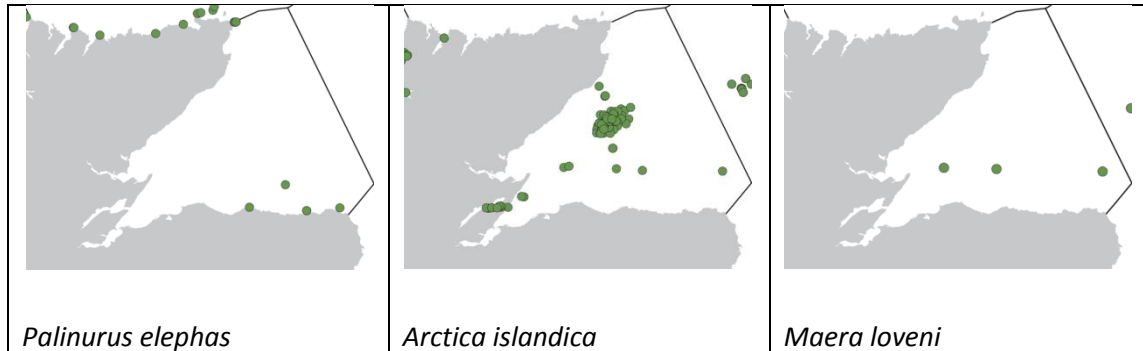

Figure 5-9: Distribution maps of PMF species taken from Scotland’s Marine Atlas (2011).

The biotope “sea-pen and burrowing megafauna” is a component of the draft PMF list ‘burrowed mud’ habitat. Based upon the distribution of seapens (Greathead *et al.*, 2007) and OSPAR map data (Figure 5-10), this habitat type is expected within the current scoping study area.

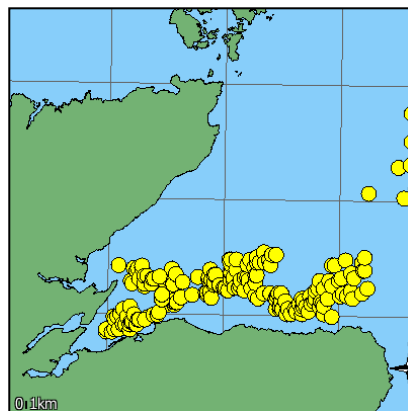

Figure 5-10: OSPAR ‘Seapen and burrowing megafauna’ habitat as mapped by the NBN Gateway in the Moray Firth Sea Area

The Southern Trench reaches at least 250 m in depth and is more than 120 km in length (Holmes *et al.*, 2004). It has been associated with the draft PMF list cold water coral reef formed by the species *Lophelia pertusa* (Hall-Spencer and Stehfest, 2009). The avoidance of the trench under current routing scenarios suggests that the export cable will not interact with cold water *Lophelia* reef.

Potential Annex I cobble reef and potential Annex I *Sabellaria spinulosa* reef have been recorded offshore of the landfall sites of the BOWL export cable and MORL previously proposed export cable at Fraserburgh.

Data Gaps

Site specific surveys will be required to determine the potential for Annex I habitats, UK Biodiversity Action Plan and PMF features.

Environmental Impacts Scoping

Based on available literature and previous scoping advice, the following are perceived to be the potential effects on benthic ecology as a result of the proposed transmission infrastructure:

Effect Description	Potential site specific effect	Potential cumulative and/or in-combination effect
Temporary increases in suspended sediment concentrations from trenching, augering, seabed preparation (plume effects) and temporary increases in sediment deposition from plumes	✓	✓
Release of contaminants bound in sediments	✓	✓
Loss of and change to seabed habitat through presence of platform substructures and foundations, and (albeit temporary) loss due to export cabling	✓	✓
Habitat and associated community change due to the placement of scour and cable protection material and presence of platform structures and foundations including the increase in the risk of the introduction and spread of marine invasive non-native species.	✓	✓
Heat and electromagnetic field (EMF) emissions from operational cables	✓	✓

Impact Assessment Methodology

For each of the potential effects described above a survey or study and method of impact assessment is described in the tables below. The potential effects listed have been developed from (a) relevant guidance notes, (b) the MORL ES (2012) and (c) ESs published for other Round 1, Round 2, Scottish Territorial Waters and Round 3 offshore wind farms.

Potential Effect	Temporary increases in suspended sediment concentrations from trenching, augering, seabed preparation (plume effects) and resultant temporary increases in sediment deposition from plumes.
Survey/Study Proposed to Assess Effect	<p>Potentially sensitive receptors include:</p> <ul style="list-style-type: none"> - Filter/suspension feeding species - Annex I & II and PMF features <p>To determine potential ecological effects of increases in suspended sediment loads and deposition on benthic communities the following studies and surveys are proposed: Seabed video tow</p>
Method of Impact Assessment	<p>The benthic environment will be described using standard marine ecological survey techniques (i.e. bathymetry and sidescan sonar with ground truthing using, drop down video; Davies <i>et al.</i>, 2001; Ware & Kenny, 2011; CEFAS <i>et al.</i>, 2004; Judd, 2011). Biotope extent and distribution will be determined with reference to geophysical data. An assessment of effects of sediment resuspension and deposition upon the epibenthos will be carried out within the updated assessments based on a review of the scientific literature, results of the site specific survey and results of monitoring data from other Round 1, 2, 3 and Scottish Territorial Waters (STW) offshore wind farms. Effect significance will be determined using standard EIA methodologies (i.e. IEEM). Annex I reefs (where present) will be identified using methodologies compiled by JNCC (Gubbay, 2007; Irving, 2009; Limpenny, 2010).</p>

Potential Effect	Release of contaminants bound in sediments
Survey/Study Proposed to Assess Effect	<p>Potentially sensitive receptors include:</p> <ul style="list-style-type: none"> - Filter/suspension feeding species - Annex I & II and PMF features - Trophic web <p>To determine potential contaminants bound in the sediments the following studies and surveys are proposed: Desk top study of historical contaminants within the surrounding seabed. If historical contamination is identified then it may be necessary, following discussions with statutory authorities to undertake grab sampling and chemical analysis of sediments. Chemical determinants will include metals, PAHs, total hydrocarbons, PCBs and total organic carbon content subject to agreement with Marine Scotland.</p>
Method of Impact Assessment	<p>The data obtained during the desk study (and any site specific survey) will be used to assess the likelihood of sediment contamination using standard EIA methodologies and comparison against Scottish and CEFAS Action Levels In Dredged Materials.</p>

Potential Effect	Loss of seabed habitat through presence of platform substructures and foundations, and (albeit temporary) loss due to export cabling
Survey/Study Proposed to Assess Effect	<p>Potentially sensitive receptors include:</p> <ul style="list-style-type: none"> - Regional benthic community <p>To determine potential loss of (and temporary disturbance to) seabed habitat the following studies and surveys are proposed: Seabed video tow (as outlined above) Intertidal habitat mapping</p>
Method of Impact Assessment	Potential effects through direct habitat loss will be assessed via quantifying any losses in terms of % loss of certain biotopes/habitats, where appropriate, previous experience gained during the assessment of Round 1, 2 and 3 and STW OWF and standard EIA methodologies (i.e. IEEM).

Potential Effect	Habitat and associated community change due to the placement of scour and cable protection material and presence of platform structures and foundations including the increase in the risk of the introduction and spread of marine invasive non-native species.
Survey/Study Proposed to Assess Effect	<p>Potentially sensitive receptors include:</p> <ul style="list-style-type: none"> - Local and regional benthic community <p>To determine the potential change in habitat and associated communities due to the placement of infrastructure on the seabed the following studies and surveys are proposed: Seabed video tow (as described above) Intertidal habitat mapping</p>
Method of Impact Assessment	Potential effects will be assessed via desk review of likely colonising species including marine invasive non-native species as a result of the introduction the export cable and associated infrastructure.

Potential Effect	Heat and electromagnetic field (EMF) emissions from operational cables
Survey/Study Proposed to Assess Effect	<p>Potentially sensitive receptors include:</p> <ul style="list-style-type: none"> - Local benthic community <p>To determine the potential effects of heat and EMF emissions from operational cables, the following studies and surveys are proposed: Seabed video tow Intertidal habitat mapping</p>
Method of Impact Assessment	Potential effects will be assessed via desk review of potentially sensitive species.

Site-specific Survey Methodology

BEST PRACTICE GUIDANCE

The following references provide best practice guidance for use in assessing effect upon benthic ecology:

- Davies *et al.* (2001). Marine Monitoring Handbook
- Ware, S.J. & Kenny, A.J. (2011). Guidelines for the conduct of benthic studies at marine aggregate extraction sites. 2nd edition. Marine Aggregate Sustainability Fund 80pp.
- NMMP (2003). National Marine Monitoring Programme Green Book. V7.
- CEFAS (2004). Offshore Wind Farms: guidance notes for Environmental Impact Assessment in respect of FEPA and CPA requirements. Version 2
- DEFRA (2005) Nature conservation guidance on offshore wind farm development
- Hendrick *et al.* (2006). *Sabellaria spinulosa* reef: a scoring system for evaluating 'reefiness' in the context of the Habitats Directive
- Gubbay (2007). Defining and Managing *Sabellaria spinulosa* Reefs: Report of an Inter-agency Workshop
- OSPAR (2008). OSPAR Guidance on Environmental Considerations for Offshore Wind Farm Development
- IEEM (2009). Guidelines for Ecological Impact Assessment in Britain and Ireland - Marine and Coastal Consultation document
- Irving (2009). Identification of the Main Characteristics of Stony Reef Habitats under the Habitats Directive. Summary of an Inter-agency Workshop 26-27, March 2008
- Limpenny *et al.* (2010). Best methods for identifying and evaluating *Sabellaria spinulosa* and cobble reef. Aggregate Levy Sustainability Fund Project MAL0008. JNCC, Peterborough.

SURVEY DESIGN

Benthic surveys have already been completed for the EDA of the MORL Zone and this will be used to assess the potential effect of the OSPs.

The following provides an indicative scope to undertake a benthic ecology characterisation utilising a drop-down seabed video to characterise the export cable route study area so that potential effects may be identified and assessed and also to inform a subsequent preconstruction (baseline) survey. The proposed survey and a brief methodology is outlined in the following sections and will be similar in methodology to the survey undertaken for the previous cable route, as detailed in the MORL ES (2012). The final survey design will be based upon MESH and Admiralty Chart data with additional in-fill survey based on the findings of the geophysical survey, if required, and will be agreed with Marine Scotland, JNCC and SNH.

DROP DOWN VIDEO SURVEY

Depending on the advice of SNH, JNCC and Marine Scotland Science (MSS), a drop-down video survey may be undertaken of the offshore cable corridor. The deployment of a video would allow the identification of epibenthic species and biotopes and any potential Annex 1 features designated under the Habitats Directive features by trained marine biologists in the field.

The video footage and photographic stills will be geo-referenced and used to assign epibenthic biotopes based on the habitat and species present. Species will be identified and enumerated from selected representative video stills. Substrate composition will be recorded based upon principal sediment characteristic (i.e. rippled fine sand, coarse sand etc.). Epibenthic biotope classification will then be conducted using the JNCC Marine Habitat Classifications for Britain and Ireland (Conner *et al.*, 2004) based on those communities present. Classified epibenthic biotopes, will be mapped throughout the export cable corridor with the extents of the boundaries interpolated using available acoustic data drawn from the geophysical surveys. Any sensitive features, such as PMF or Annex I habitats will be recorded.

Relevant data will then be transferred to GIS format so that spatial plotting of information can be achieved. Information gathered from the benthic surveys will be interpreted to provide a biotope map for the area and detailed information on the location and extents of any Annex I habitats and PMF features within the vicinity of

the export cable corridor. The report will highlight significant species and habitats within the context of nature conservation. Where appropriate, reference will be made to relevant legislation and the known geographical distribution of the feature.

PARTICLE SIZE DISTRIBUTION (PSD) AND SEDIMENT CHEMISTRY ANALYSES

Where required, sediment samples will be obtained using a 0.1 m² stainless steel Day or Hamon grab sampler. Each sediment sample for particle size distribution (psd) analysis will be processed in the laboratory through sieves over the range 64 mm to 63 µm (0.063 mm) on the Wentworth scale in accordance with Ware & Kenny (2011) to determine the particle size composition of the seabed sediments. The sediment is washed through a 63 µm (0.063 mm) sieve and the retained material oven dried at 800°C before being transferred to the coarsest of a series of stacked sieves.

These are placed on an automatic shaker for 15 minutes and the contents of each sieve subsequently weighed. Material washing through the 63 µm sieve will be collected in pre-weighed beakers, oven dried at 3000C and weighed as a separate fraction. This fraction can be analysed by laser sizing should this be required for coastal process studies.

For each sampling station the results will be expressed as cumulative percentage of each particle size passing through each sieve size. For the purposes of the report and the statistical analysis to be carried out, these percentages are converted to absolute percentage retained on each sieve size.

These psd data will be used to inform the coastal and sediment processing modelling and the biotope classification.

Samples for determination of sediment chemistry will be transferred to a UKAS accredited laboratory for analysis (specific determinants to be agreed with Marine Scotland and SNH/JNCC).

DATA ANALYSIS

Biotopes will be defined from a synthesis of the physical and biological video data and mapped throughout the export cable corridor. The extents of the boundaries of each biotope will be interpolated using available acoustic data drawn from the geophysical surveys.

Biotopes will be the principal biological unit for appraisal of the predicted effects of installation and operation of the TI. Considerable information exists concerning the sensitivity characteristics of biotopes (e.g. MarLIN) making them particularly suitable for EIA. MarLin will therefore be a principal data source underpinning the ecological assessments and reducing the uncertainties associated with such assessments.

Cumulative and In-combination Impact Assessment & Survey Methodologies

The cumulative and in-combination impact assessment principles outlined in the MFOWDG Cumulative effects Assessment Discussion Document (ERM, 2011) are also of relevance to the EIA for the TI for MORL and BOWL. The principal considerations that must be contemplated include physical disruption directly due to the installation and construction of the cable and OSP infrastructure and indirectly through movement of sediment and changes in the hydrodynamic regime. Additional effects from heat transfer from cabling are understood to cause little or no effect on benthic communities. Accidental spillage from the development infrastructure during construction is a possibility but this will be mitigated within respective construction and operational environmental management plans.

Potential Mitigation Methods

Potential mitigation measures for marine benthic effects include micro-siting OSPs and the export cable around features and choice of installation techniques. Control of bio-fouling and ballast water management measures for construction and operation and maintenance vessels will mitigate for the introduction and spread of marine invasive non-native species.

The mitigation measures proposed for the final OfTI will be dependent upon the final design and the potential effects as determined by the EIA studies.

5.2.3 Fish and Shellfish Ecology

Baseline Environment

SPAWNING AND NURSERY AREAS

There are various spawning and nursery grounds in the vicinity of the proposed OfTI corridor. Table 5-1 below lists the species which have spawning grounds coinciding with the OfTI and the expected seasonality and intensity of spawning events. The table also lists the species with nursery grounds coinciding with the OfTI and the expected intensity of use of these grounds. Spawning and nursery grounds are dynamic features of fish life history and are rarely fixed in one location from year to year. In addition, fish may spawn earlier or later in the season in response to environmental change. Therefore, the information provided in Figure 5-11 and Figure 5-12 represents the widest known and most up to date published distribution of spawning and nursery grounds.

Table 5-1. Details of fish species spawning and nursery activity within the Moray Firth

Species	Seasonality of Spawning (Intensity and Peak Spawning *)												Nursery (Intensity)
	Jan	Feb	Mar	Apr	May	Jun	Jul	Aug	Sep	Oct	Nov	Dec	
Cod		*	*										
Herring													
Lemon Sole													
<i>Nephrops</i>				*	*	*							
Plaice	*	*											
Sandeel													
Sprat					*	*							
Whiting													
Anglerfish	N / A												
Blue Whiting	N / A												
Haddock	N / A												
Hake	N / A												
Ling	N / A												
Mackerel	N / A												
Saithe	N / A												
Spotted Ray	N / A												
Spurdog	N / A												
Thornback Ray	N / A												

Colour Key: (red) = high Intensity Spawning / Nursery Ground, (yellow) = low Intensity Spawning / Nursery Ground, (green) = unknown Intensity, (*) = Peak Spawning

SANDEELS

Sandeel spend most of the year buried in the seabed. They only emerge into the water column to spawn and feed. Feeding occurs over an extended period during spring and summer. The presence of sandeels is highly dependent on the presence of an adequate substrate in which to burrow.

Surveys of the sandeel population within the Zone were undertaken by MORL in 2012. These surveys identified three species of sandeels within the area: Raitt’s sandeel (*Ammodytes marinus*), greater sandeel (*Hyperoplus lanceolatus*) and smooth sandeel (*Gymnammodytes semisquamatus*). The highest densities of sandeels were sampled within the western development area (WDA) of the MORL Zone adjacent to the Stevenson wind farm site. The majority of samples within the EDA had zero sandeel counts.

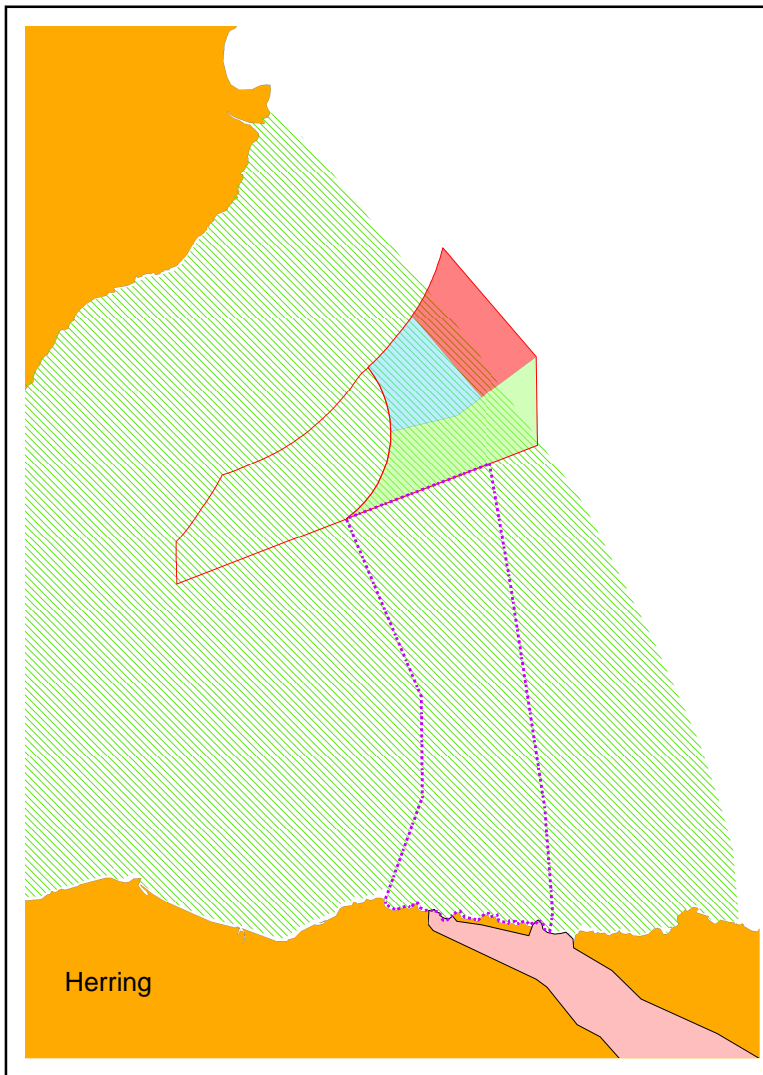

Herring

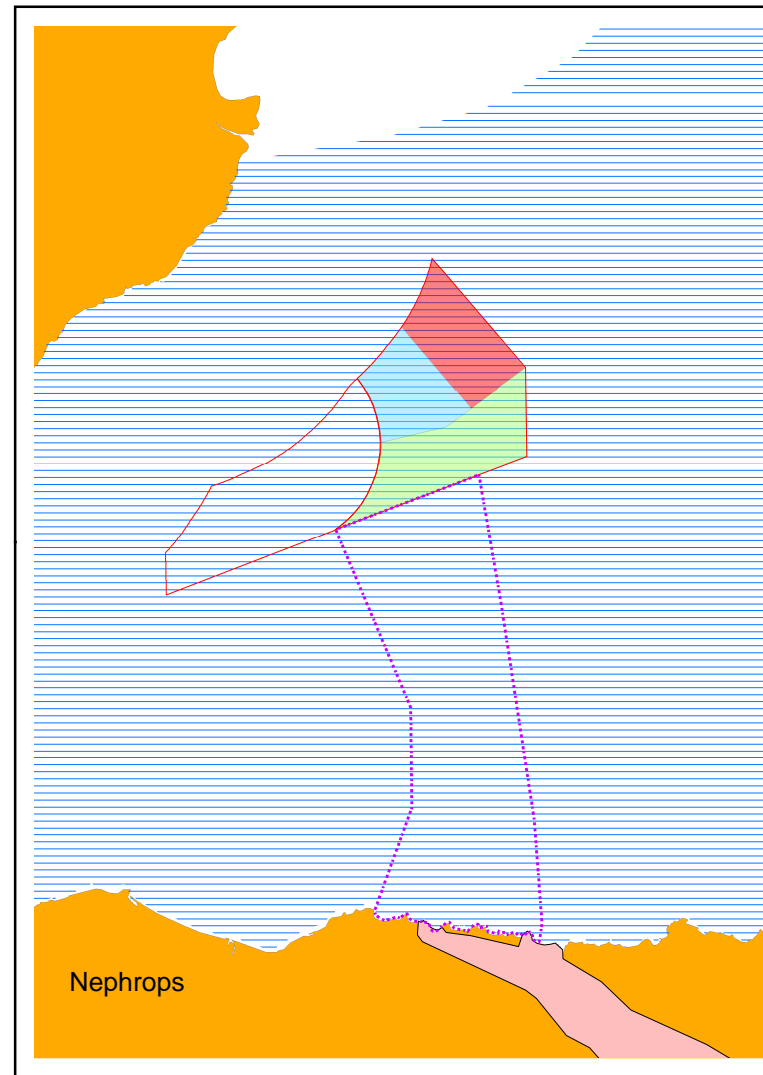

Nephrops

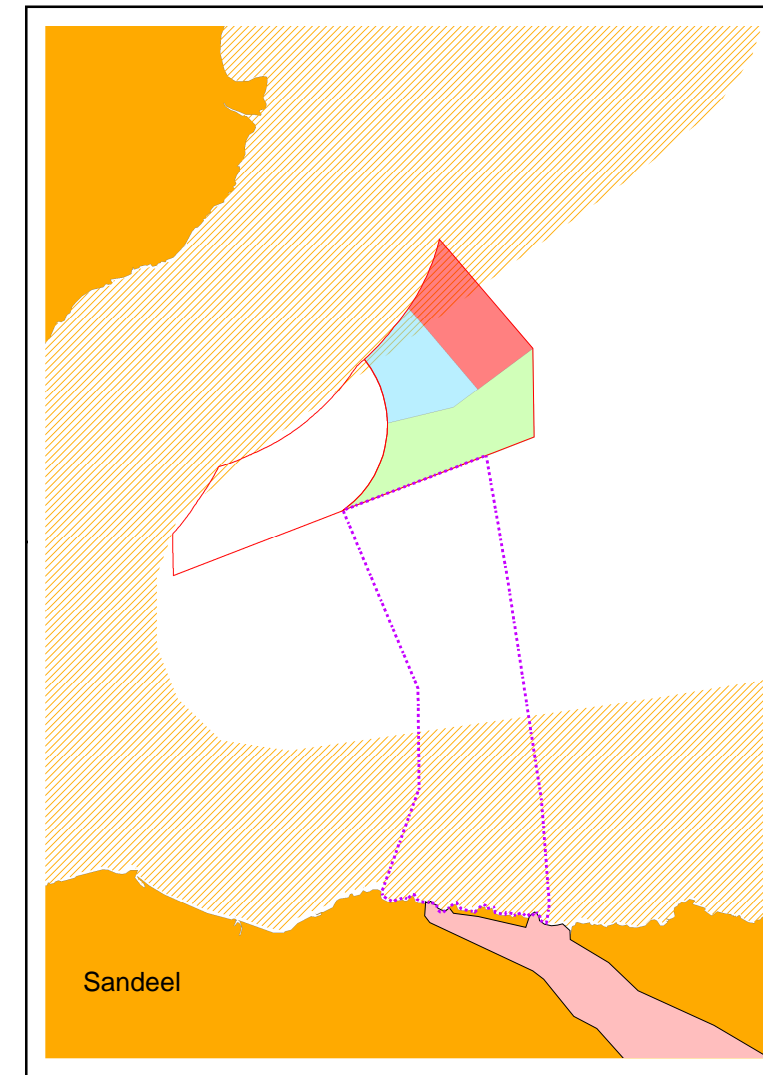

Sandeel

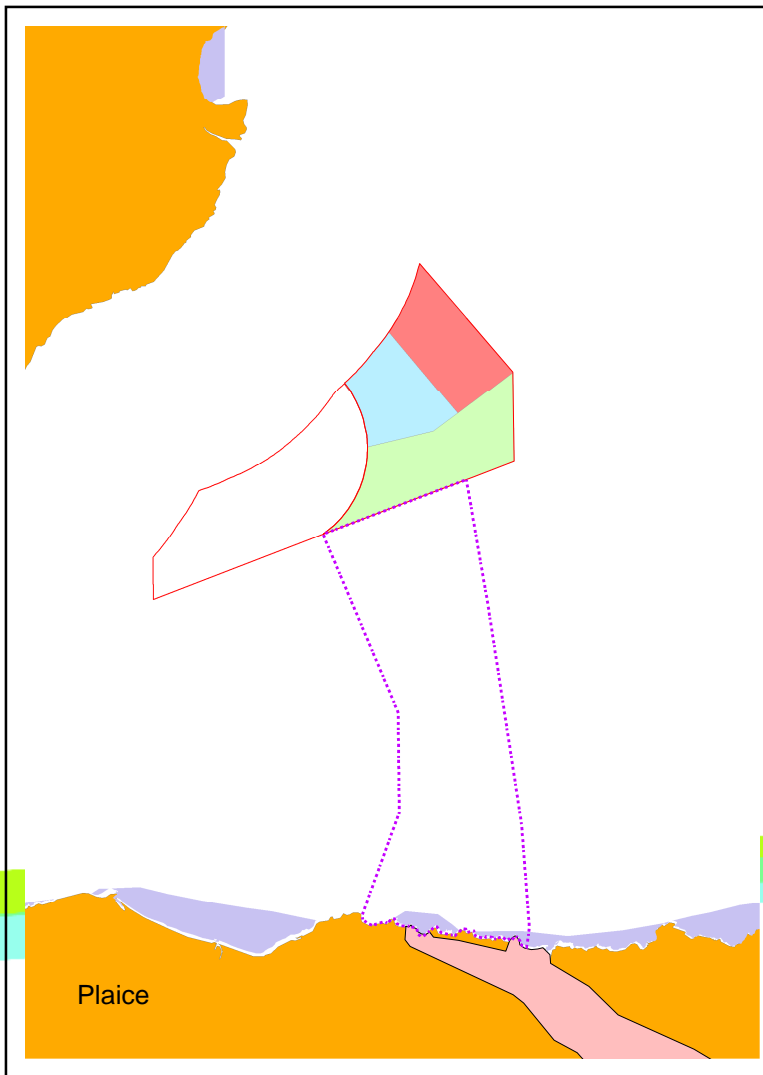

Plaice



Sprat

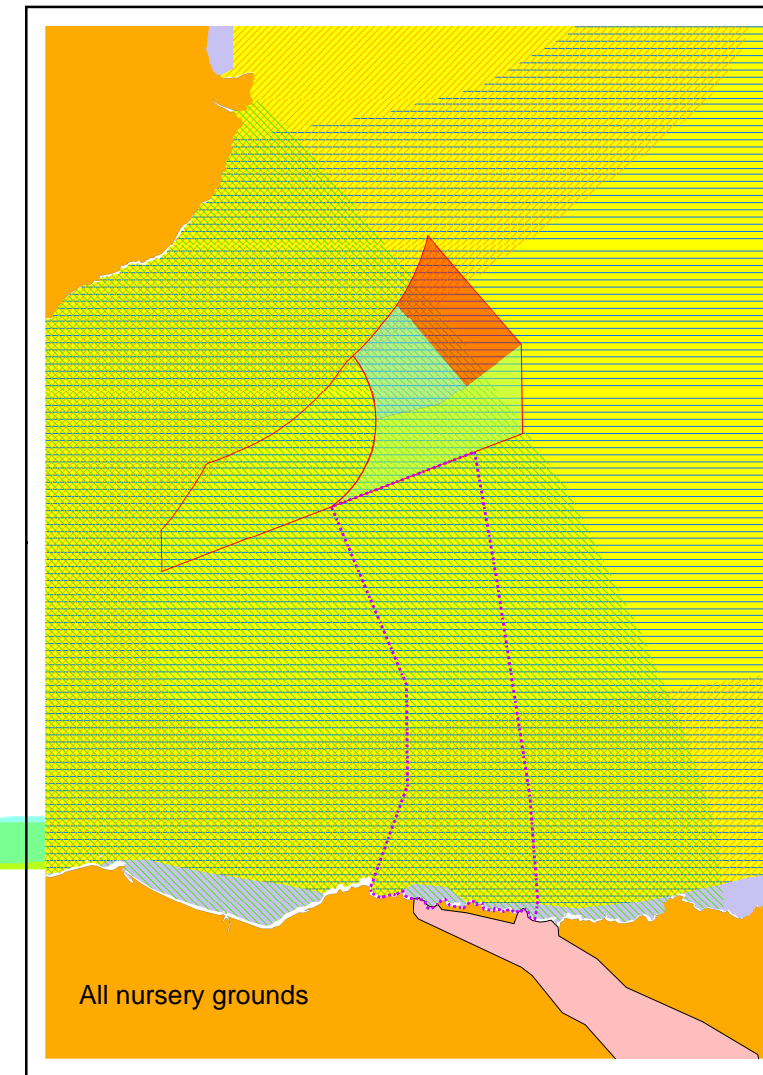

All nursery grounds



Moray Offshore Renewables Ltd

KEY

- Offshore Cable Corridor
- Onshore Cable Corridor Search Area
- The Zone
- Herring Nursery Grounds
- Plaice Nursery Grounds
- Sandeel Nursery Grounds
- Nephrops Nursery Grounds
- Sprat Nursery Grounds

Source: Fisheries Sensitivities Maps in British Waters (Coull et al., 1998), CEFAS

Horizontal Scale: 1:800,000

A3 Chart

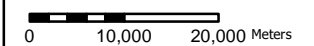

Geodetic Parameters: WGS84 UTM Zone 30N

Produced: RH
Reviewed: PM
Approved: SP

Date: 07/04/2014 Revision: C

REF: 8460001-PSO0010-MOR-MAP-040

Fig 5-11 Nursery Grounds within the Moray Firth

Moray Offshore Renewables Ltd

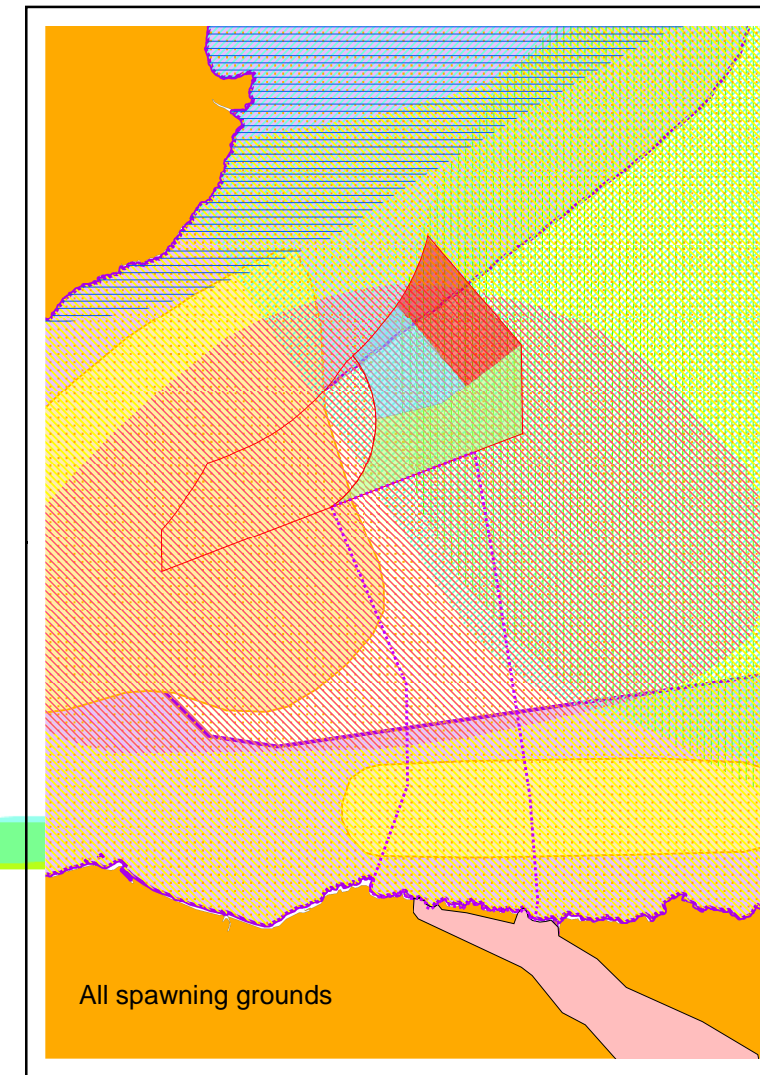
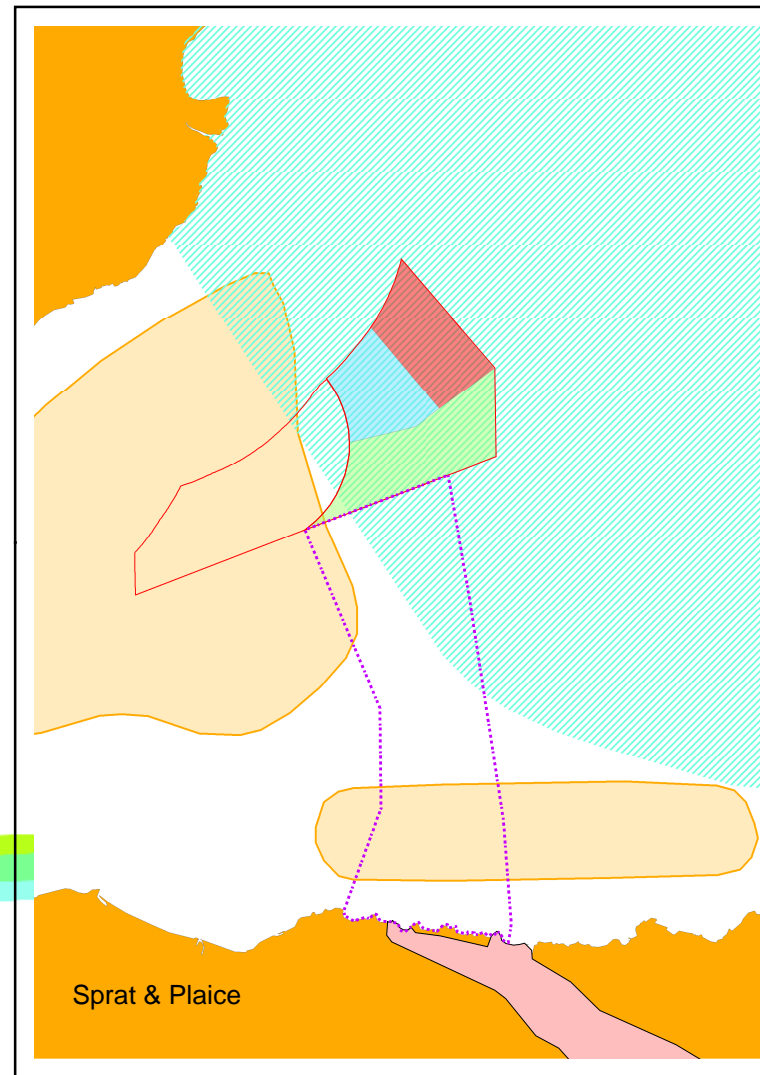
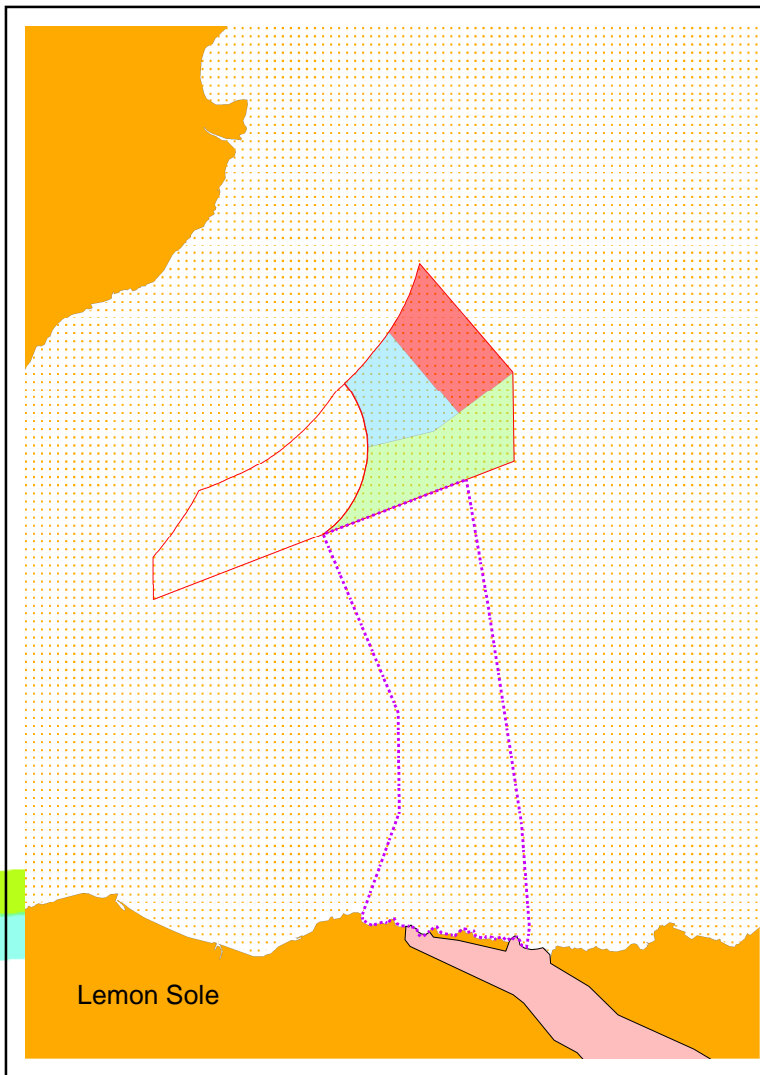
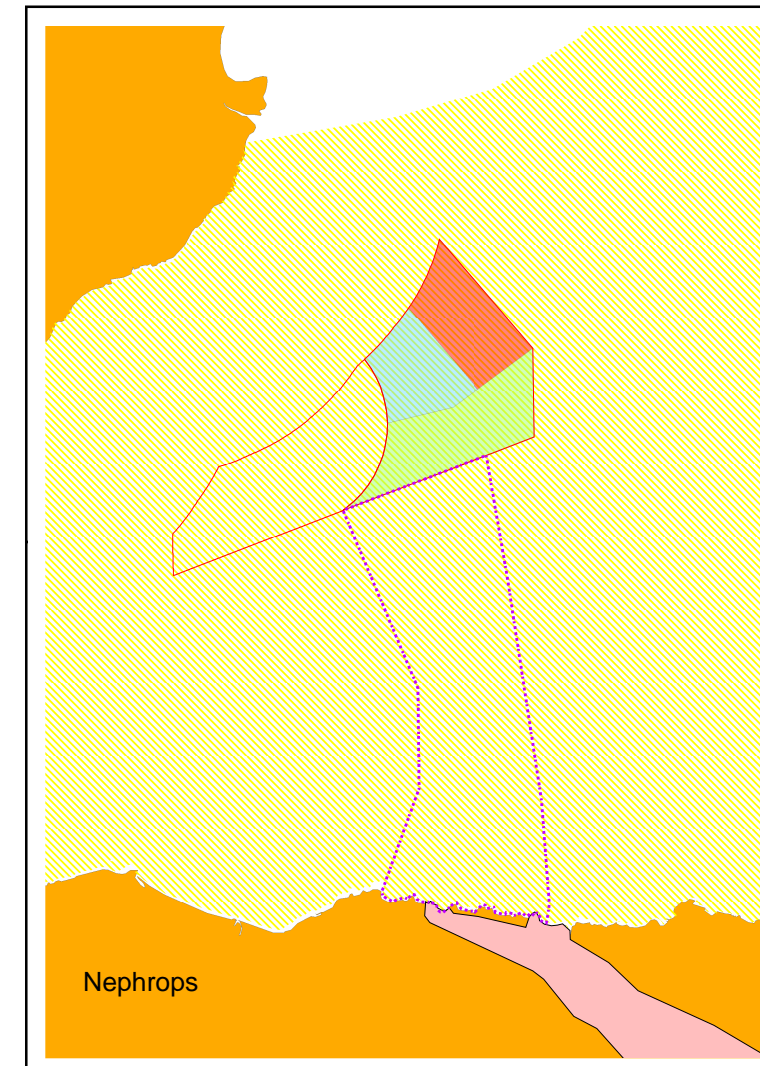
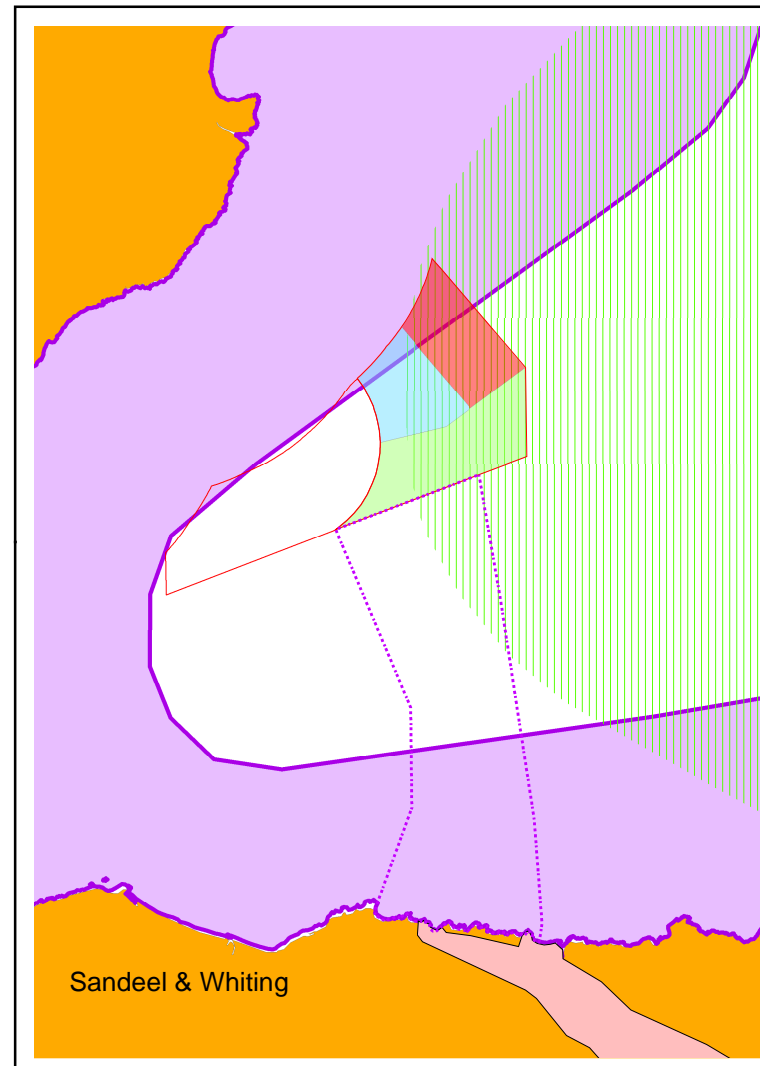
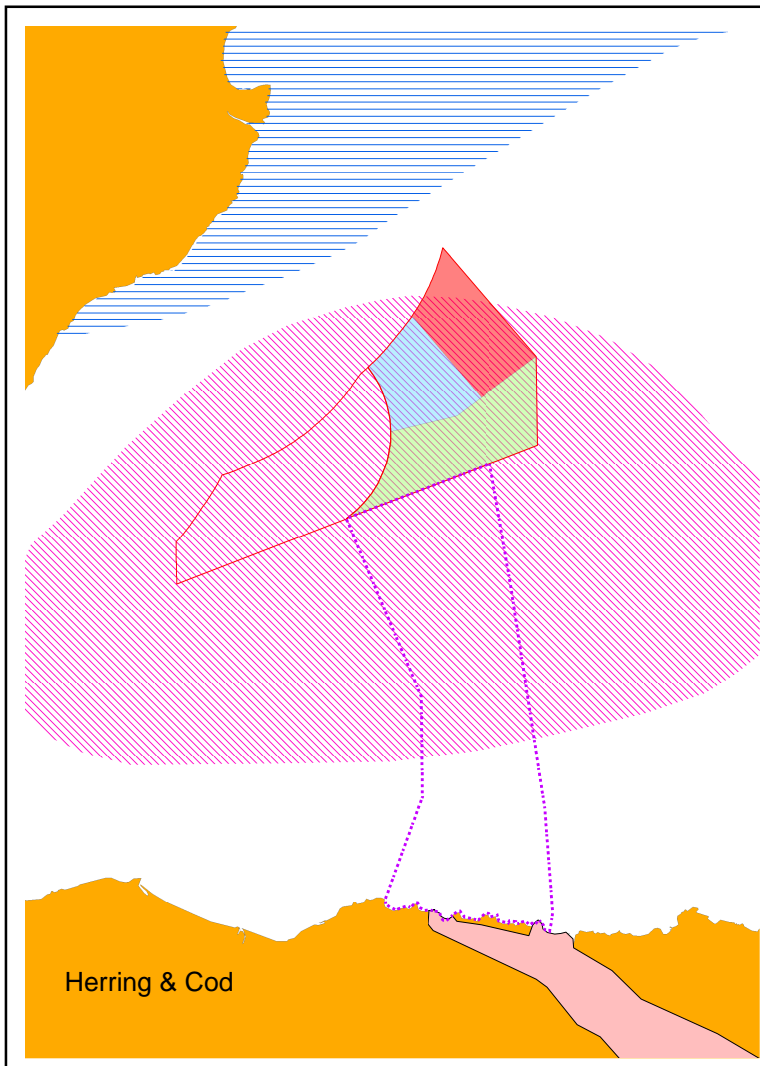

KEY

-  Offshore Cable Corridor
-  Onshore Cable Corridor Search Area
-  The Zone
-  Cod
-  Herring
-  Lemon Sole
-  Nephrops
-  Whiting
-  Sprat
-  Plaice
-  Sandeel

Source: Fisheries Sensitivities Maps in British Waters (Coull et al., 1998), CEFAS

Horizontal Scale: 1:800,000

A3 Chart

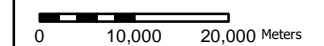

Geodetic Parameters: WGS84 UTM Zone 30N

Produced: RH
Reviewed: PM
Approved: SP

Date: 07/04/2014 Revision: C

REF: 8460001-PSO0010-MOR-MAP-041

Fig 5-12 Spawning Areas within the Moray Firth

DIADROMOUS SPECIES

Within the Moray Firth there are several species that migrate between fresh and salt waters. These are the Atlantic salmon (*Salmo salar*), sea trout (*Salmo trutta*), sea lamprey (*Petromyzon marinus*), river lamprey (*Lampetra fluviatilis*), eel (*Anguilla anguilla*), twaite shad (*Alosa fallax*) and allis shad (*Allosa alosa*) (Barnes *et al.*, 1996; DTI, 2004). Atlantic salmon, river and sea lamprey, twaite shad and allis shad are listed as protected species in Annex II of the EU Habitats Directive. Sea trout are also a UKBAP species. These species are anadromous, spawning in freshwaters and completing their life cycle in the marine environments. An exception to this is the European eel which are catadromous. They spawn in the Sargasso Sea and enter the freshwater habitat as juveniles (glass eels). Several sites with the Moray Firth area have been designated Special Areas of Conservation (SACs) for the presence of one or more of the Annex II species, as described in Table 5-2 and shown in Figure 5-13 (JNCC, 2010).

Table 5-2: SACs designated for natural fish or freshwater pearl mussel* interest the Moray Firth area.

Site	Minimum Distance From the River Mouth to MORL's Proposed Offshore Route Corridors	Relevant SAC Qualifying Feature
Berridale and Langwell Waters SAC	41 km (direct distance)	Annex I Habitats: none Annex II species (primary feature): Atlantic salmon (<i>Salmo salar</i>).
River Spey SAC	21 km (direct distance)	Annex I Habitats: none Annex II species (primary features): Freshwater pearl mussel (<i>Margaritifera margaritifera</i>), sea lamprey (<i>Petromyzon marinus</i>), Atlantic salmon (<i>Salmo salar</i>), otter (<i>Lutra lutra</i>)
River Thurso SAC	50 km (approximate)	Annex I Habitats: none Annex II species (primary features): Atlantic salmon (<i>Salmo salar</i>).
River Evelix SAC	77 km (approximate)	Annex I Habitats: none Annex II species (primary feature): Freshwater pearl mussel (<i>Margaritifera margaritifera</i>).
River Oykel SAC	92 km (approximate)	Annex I Habitats: none Annex II species (primary feature): Freshwater pearl mussel (<i>Margaritifera margaritifera</i>). (secondary feature): Atlantic salmon (<i>Salmo salar</i>).
River Moriston SAC	123 km (approximate)	Annex I Habitats: none Annex II species (primary features): Freshwater pearl mussel (<i>Margaritifera margaritifera</i>). (secondary feature): Atlantic salmon (<i>Salmo salar</i>).

* The species is dependent on the presence of salmonid fish as the larvae lodges on their gills.

© Scottish National Heritage
 © Seazone Solutions Limited, 2005, [012009.001, 022011.009]. This product includes mapping data licensed from Ordnance Survey (Great Britain) with the permission of HMSO. © Crown Copyright, 2006. All rights reserved.
 Moray Offshore Renewables Ltd © 2014. This document is the property of contractors and sub-contractors and shall not be reproduced nor transmitted without prior written approval.

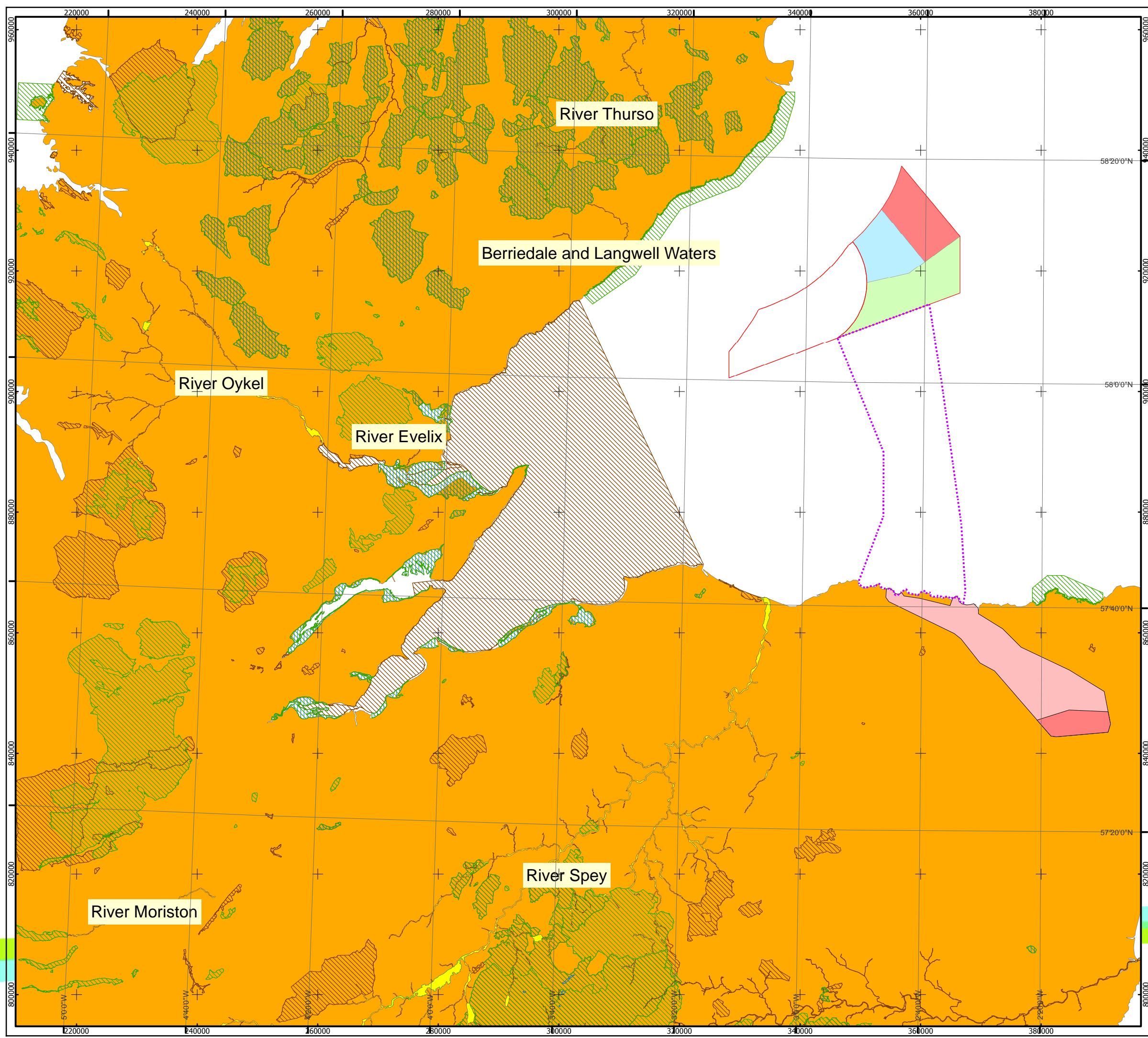

Moray Offshore Renewables Ltd

- KEY**
- SACs for diadromous fish species
 - SPAs SCOTLAND
 - SACs SCOTLAND
 - RAMSAR SITES SCOTLAND
 - Offshore Cable Corridor
 - Onshore Substation Search Area
 - Onshore Cable Corridor Search Area
 - The Zone

Horizontal Scale: 1:600,000 A3 Chart N
 0 10,000 20,000 Meters

Geodetic Parameters: British National Grid

Produced: RH
 Reviewed: PM
 Approved: SP

Date: 07/04/2014 Revision: C
 REF: 8460001-PSO0010-MOR-MAP-042

Fig 5-13 Designated sites for diadromous fish species

Moray Offshore Renewables Ltd

Salmon and sea trout are also recognised under the UK Salmon and Freshwater Fisheries Act (1975). In addition, salmon and sea trout support fisheries of importance from a socioeconomic point of view in the region. Allis and twaite shad are also protected under Schedule 5 of the Wildlife and Countryside Act 1981.

ELECTROMAGNETIC SENSITIVE SPECIES AND ELECTROMAGNETIC FIELDS

A number of reports have been produced in recent years that investigate issues surrounding the potential for sub-sea power cables required for offshore wind farms to create electromagnetic fields (EMF) (Gill, A.B. & Bartlett, M., 2010). Marine Scotland Science is also shortly expected to publish results of a study into the effects of EMF on fish species. Specific concerns have been expressed that such fields have the potential for an effect on electro and magnetosensitive species, mainly migratory fish (e.g. European eel, salmon, etc) and elasmobranchs (sharks and rays).

COMMERCIAL SPECIES

The principal commercial fish and shellfish species in the area relevant to the OfTI are discussed in section 5.3.2. It should be noted, that the distribution range of some of these (e.g. Nephrops and scallops) is also dependent on the presence of a suitable substrate. Commercial species have a grouped action plan and some individual commercial species (e.g. cod and mackerel) have individual species action plans under the UKBAP.

Data Gaps

There are gaps in the current knowledge of the distribution, behaviour and ecology of certain species. This is particularly evident for a number of migratory species (e.g. salmon, European eel) for which little is known in relation to exact migration routes and the use that they may make of coastal areas such as the Moray Firth. In recognition of the gaps in current knowledge Marine Scotland Science have produced a National Research and Monitoring Strategy for Diadromous Fish (NRMSDF) to inform and address specific concerns. MORL continues to engage with MSS regarding this research plan and sits on the NRMSDF steering group as a representative for the offshore wind industry.

Environmental Impacts Scoping

Based on available literature, the following are perceived to be the potential effects on fish and shellfish as a result of proposed OfTI:

Effect Description	Potential site specific effect	Potential cumulative and/or in-combination effect
Habitat loss and displacement	✓	✓
Disturbance to nursery/spawning grounds as a result of construction and increases in sediment deposition	✓	✓
Effects associated with construction and operational noise of the substation platforms	✓	✓
Effects of electromagnetic fields associated with cabling	✓	✓
Effects of increased sediment concentrations	✓	✓

Site-specific Impact Assessment Methodology

For each of the potential effects described above a survey or study and method of impact assessment is described in the tables below.

Potential Effect	Habitat loss and displacement
Survey/Study Proposed to Assess Effect	<p>Potentially sensitive receptors include:</p> <ul style="list-style-type: none"> - Regional fish and shellfish communities <p>To determine the potential for habitat loss and displacement, the following surveys and studies will be undertaken:</p> <p>Fish and shellfish desk based study Review of commercial fisheries study (e.g. fishing grounds) Review of benthic study and particle size analysis</p>
Method of Impact Assessment	The spatial and temporal use that fish and shellfish species make of the study area will be described and the potential for habitat loss through substation placement and temporary habitat loss and disturbance as a result of the offshore export cable installation related operations will be assessed.

Potential Effect	Disturbance to nursery/spawning grounds as a result of construction and sediment deposition
Survey/Study Proposed to Assess Effect	<p>Potentially sensitive receptors include:</p> <ul style="list-style-type: none"> - Species with spawning/nursery grounds within the Moray Firth <p>To determine the potential for disturbance to nursery and spawning grounds the following surveys and studies will be undertaken:</p> <p>Fish and shellfish desk based study Review of coastal processes study</p>
Method of Impact Assessment	Potential effects on spawning habitats through increased sediment loads will be assessed using the outputs of the coastal process assessment and published data on the sensitivity of fish species found to be spawning in this area to high sediment loads (including Round 1, 2 and 3 and STW OWF data).

Potential Effect	Effects associated with construction and operational noise of the substation platforms
Survey/Study Proposed to Assess Effect	<p>Potentially sensitive receptors include:</p> <ul style="list-style-type: none"> - Regional fish and shellfish communities - Species with spawning/nursery grounds within the Moray Firth <p>To determine levels of disturbance associated with noise the following studies and surveys will be undertaken:</p> <p>Fish and shellfish desk based study</p>
Method of Impact Assessment	Potential noise effects during the construction phase on fish and shellfish species will be assessed via a review of the relatively large body of data that exists on this topic, including developer-led work and COWRIE projects (Bio/Consult AS, 2001; Wahlberg and Westerberg, 2005; Nedwell <i>et al.</i> , 2007). Use of assessment tools such as audiograms and species-metrics will be adopted.

Potential Effect	Effects of electromagnetic fields associated with cabling
Survey/Study Proposed to Assess Effect	<p>Potentially sensitive receptors include:</p> <ul style="list-style-type: none"> - Electro and magneto-sensitive species <p>To determine the distribution of electro and magneto-sensitive species the following studies and surveys will be undertaken: Fish and shellfish desk based study</p>
Method of Impact Assessment	The findings of recent COWRIE projects (Gill <i>et al.</i> , 2005, Gill <i>et al.</i> , 2009) and SNH reports (Gill & Barlett, 2010) investigating the effects of EMF on sensitive fish species will be used to determine the significance of any effects on fish species from EMF associated with the offshore export cables.

Potential Effect	Effects of increased sediment concentrations
Survey/Study Proposed to Assess Effect	<p>Potentially sensitive receptors include:</p> <ul style="list-style-type: none"> - Regional fish and shellfish communities - Species with spawning/nursery grounds <p>To determine potential disturbance from sediment plumes the following studies will be undertaken: Coastal processes study Fish and shellfish desk based study Particle Size Analysis.</p>
Method of Impact Assessment	Potential effects of increased sediment loads will be assessed using the outputs of the coastal process assessment, published data on the sensitivity of fish species (including Round 1, 2 and 3 and Scottish Territorial Water offshore wind farm data) found in this area to high sediment loads and standard EIA methodologies.

Site-specific Survey Methodology

The following relates to the surveys for the EIA. Marine Scotland, JNCC and SNH will be consulted with regards to the requirements for information to support an Appropriate Assessment. It is noted that in some cases effects on SACs, where salmon is a designating feature, the potential for effects on the freshwater pearl mussel will also be considered.

BEST PRACTICE GUIDANCE

The following references provide best practice guidance for use in assessing effects upon fish and shellfish ecology:

- Davies *et al.* (2001) Marine Monitoring Handbook
- CEFAS (2004) Offshore Wind Farms: guidance notes for Environmental Impact Assessment in respect of FEPA and CPA requirements. Version 2
- DEFRA (2005) Nature conservation guidance on offshore wind farm development
- OSPAR (2008) OSPAR Guidance on Environmental Considerations for Offshore Wind Farm Development

Summary of Methodology

The final methodology will be determined in discussion with MSS, JNCC and SNH.

FISH AND SHELLFISH DESK BASED STUDY

The study will be undertaken by marine scientists in order to gather data for the area to inform the development of suitable site specific sampling strategies. The desk based study will entail an interrogation of available datasets and literature and consultation with relevant stakeholders. Data will be collated and mapped in GIS to illustrate the spatial and temporal scales of fish and shellfish assemblages, species of commercial importance, nursery and spawning areas and the occurrence of migratory species and species of conservation importance.

Cumulative and In-combination Impact Assessment & Survey Methodologies

The methodologies outlined within the MFOWDG Cumulative Impacts Assessment Discussion Document (ERM, 2011) are also of relevance for the OfTI. The report states that potential effects could occur through disruption of behavioural pattern, such as migratory or spawning activity, changes to composition due to displacement, loss of habitat and adaptations to prey availability. There is potential for direct disruption through construction as well as the potential effects of EMFs from the offshore export cables.

Potential Mitigation Methods

Potential mitigation measures for effects on fish and shellfish include choice of installation techniques for OSP foundations and export cables, and timing of construction activities.

The mitigation measures proposed for final OfTI will be dependent upon the final design and the potential effects as determined by the EIA studies. Options of mitigation will be discussed with the relevant authorities.

5.2.4 Marine Mammals

Baseline Environment

To date, a total of 14 cetacean species have been recorded alive within the Moray Firth. Other species have been found stranded within the firth area but are not included in this review due to the uncertainty in the animals' location before death. Two species of pinniped also occur in the Moray Firth. Table 5-3 summarises the frequency of marine mammal recordings within the Moray Firth.

Table 5-3. Frequency of marine mammal recordings within the Moray Firth area.

Common Name	Latin name	Frequency of recordings
Pinnipeds		
Harbour seal	<i>Phoca vitulina</i>	Common, all year
Grey seal	<i>Halichoerus grypus</i>	Common, seasonal
Cetaceans		
Harbour porpoise	<i>Phocoena phocoena</i>	Common, all year
Bottlenose dolphin	<i>Tursiops truncatus</i>	Common, all year
Common dolphin	<i>Delphinus delphis</i>	Common, seasonal
White-beaked dolphin	<i>Lagenorhynchus albirostris</i>	Common, seasonal
Minke whale	<i>Balaenoptera acutorostrata</i>	Common, seasonal
Risso dolphin	<i>Grampus griseus</i>	Occasional
White-sided dolphin	<i>Lagenorhynchus acutus</i>	Occasional
Killer whale	<i>Orcinus orca</i>	Occasional
Pilot whale	<i>Globicephala melas</i>	Rare
Humpbacked whale	<i>Megaptera novaengliae</i>	Rare
Fin whale	<i>Balaenoptera physalus</i>	Rare
Sperm whale	<i>Physeter macrocephalus</i>	Rare
Northern bottlenose whale	<i>Hyperoodon ampullatus</i>	Rare
Beluga whale	<i>Delphinapterus leucas</i>	Rare

Two Special Areas of Conservation (SACs) have been designated within north-east mainland Scotland, one for the bottlenose dolphin (the Inner Moray Firth SAC) and another harbour seal (Dornoch Firth and Morrich More SAC) (Figure 5-13).

Harbour seals, grey seals, bottlenose dolphins and porpoises are found in the Moray Firth area all year round, with the abundance for these species in inshore areas often being higher during summer months. For cetacean species only occasionally recorded, such as fin whales, humpback whales, northern bottlenose whales, long-finned pilot whales and sperm whales, the area off north-east Scotland is only a marginal part of their habitat and is likely to be inhabited only during a restricted part of the year (Hammond *et al.*, 2004).

The most commonly recorded cetacean species within the outer Moray Firth area are: bottlenose dolphin, harbour porpoise, minke whale, white-beaked dolphin and common dolphin (Thompson *et al.*, 2009). Of these, harbour porpoise are the most commonly sighted species throughout the outer Moray Firth region. Bottlenose dolphin sightings are relatively rare in the outer Moray Firth, with the majority in the inner Moray Firth and along the southern coast, generally in waters of less than 25 m depth (Hastie *et al.*, 2003; Canning, 2007; Robinson *et al.*, 2007).

Data from a number of passive acoustic monitoring (PAM) studies dating from 2005 to 2011 were collated for the MORL ES (MORL, 2012) to examine the spatial and temporal variation of harbour porpoise and dolphins (any species) on the Smith Bank over the last five years.

Dolphins were detected regularly within the inner Moray Firth and along the southern Moray coast. Few dolphin detections were recorded in the central Firth area but detections increased again at more offshore locations, including those within the proposed OSP locations (EDA). Although it was not possible to determine which species of dolphin were present within the EDA between 2005 and 2011, a limited amount of data from between July and October 2010, indicated that during this time, bottlenose dolphins were not present within the wind farm sites. Habitat association studies for dolphin species also confirmed that any dolphins encountered along the coastal strip are most likely to be bottlenose dolphins, while those encountered in offshore areas are more likely to be another species. The Inner Moray Firth is designated as a SAC for bottlenose dolphin.

Harbour porpoise detections were common throughout Moray Firth, with the lowest levels of detection found in the coastal areas most frequently inhabited by dolphins (MORL, 2012). However, it was concluded that harbour porpoise were visiting the EDA on a daily basis.

Of the other cetacean species observed within the Moray Firth, the minke whale is the most abundant. They have been shown to prefer sandbanks, as was shown by their distribution recorded during the boat-based surveys for the MORL ES (MORL, 2012). The SCANS II surveys estimated 0.022 animals per km² for the Moray Firth, Orkney and Shetland combined, higher than the 0.01 animals per km² calculated from the boat-based surveys for the three proposed wind farm sites although the small sample size needs to be taken into account when interpreting these results.

A number of haul out sites for harbour seals can be found within the Moray Firth, primarily in the Beaully, Cromarty and Dornoch Firths and Loch Fleet (Thompson *et al.*, 1996; SCOS, 2009). Harbour seals occur throughout the year in these areas, with peak numbers at haul out sites between June and August (Thompson & Miller, 1990; Thompson *et al.*, 1996). Tagging studies within the Firth found that in summer harbour seals tend to forage quite close to their haul out sites, generally travelling no more than 60 km. They tend to forage slightly further afield in the winter and seasonal differences were found in the areas used (Thompson *et al.*, 1996). The data collected for the original ES indicates that harbour seals may be widely dispersed across the Moray Firth, particularly over offshore sandbanks. The data suggest there is variability in importance for different areas (MORL, 2012).

A study investigating habitat association and harbour seal distribution showed depth and seabed slope were significantly related to the probability of harbour seal presence. Probability of occurrence was highest at intermediate depths (approximately 15 to 50 m) and decreased with increasing seabed slope. Occurrence rate was highest within 30 km of the nearest haul-out site and declined rapidly beyond 100 km. The study also showed that seal foraging habitat preference was significantly related to sediment type, depth, slope and distance to nearest haul-out site. Sand, marine muddy sediment over sand and marine sediment were preferred over gravel, sandy, marine and gravel marine sediment. Analysis of preference also indicated foraging habitats of mid-water depth and shallow slopes away from haul-out sites were more commonly used. In general, predicted foraging habitat use was highest in the north-eastern part of the Moray Firth and in small areas to the south-east (MORL, 2012).

Harbour seals are a designating species for the Dornoch Firth and Morrich More SAC. Counts made during the breeding season at the Dornoch Firth Special Area of Conservation (SAC) indicate that there has been a steady decline in the number of seals observed since the mid-1990s with an apparent stabilisation over the last five to six years, while numbers in Loch Fleet have gradually increased. This latter area has now become an established breeding site used by over 70 individually recognisable adult females (Thompson & Wheeler, 2008; Cordes *et al.*, 2011).

Within the Moray Firth, grey seals are predominantly observed during the summer although a few can be found throughout the year. Non-breeding grey seals have been observed at the intertidal sites within the firths used by harbour seals. Breeding grey seals are mostly found at the rocky beaches and caves to the north (Thompson *et al.*, 1996). Data obtained from tagged individuals published by SMRU (McConnell *et al.*, 1999) has found that grey seal foraging trips fall into two categories: long distance trips up to 21,000 km, and short, regular trips to local feeding areas. Tagging studies within the Moray Firth found grey seals foraged over a much wider area than the harbour seal with great variation between individuals.

Data Gaps

There is an extensive amount of marine mammal data for the Moray Firth area including recent survey data collected to support the EDA offshore wind farm consents. The habitat association modelling undertaken for the MORL ES (2012) covers the wider Moray Firth including the area of the proposed offshore cable corridor and there only additional data analysis will be undertaken and no further data are proposed to be collected to inform the marine mammal impact assessment for the OFTI consent application.

Environmental Impacts Scoping

Based on available literature, the following are perceived to be the potential effects on marine mammals as a result of the OfTI:

Effect Description	Potential site specific effect	Potential cumulative and/or in-combination Effect
Disturbance and potential displacement as a result of elevated construction and operational noise (including vessel noise)	✓	✓
Increased collision risk resulting in injury or death due to construction and maintenance effects (including vessel movements)	✓	✓
Potential reduction of the feeding resource due to effects on prey of noise and vibration, and habitat disturbance	✓	✓

Site-specific Impact Assessment Methodology

For each of the potential effects described above a study and method of impact assessment is described in the tables below.

Potential Effect	Disturbance and potential displacement as a result of elevated construction and operational noise (including vessel noise)
Survey/Study Proposed to Assess Effect	<p>Potentially sensitive receptors include:</p> <ul style="list-style-type: none"> - Regional marine mammal community <p>To determine the potential for disturbance and displacement, the following studies will be undertaken:</p> <p>Modelling of marine mammal density and distribution for the cable route study area (this has been undertaken for the OSP area (EDA) within the MORL ES (2012) but will be updated)</p> <p>Literature review of marine mammal species audiograms</p> <p>Desk-top study and noise modelling to determine zones of noise around piling operations (for substations)</p> <p>Literature study of marine mammal behavioural responses to construction of offshore cables and substations.</p>
Method of Impact Assessment	<p>Marine mammal species density and distribution data will be used to model population densities across the cable route study area over time. Background noise measurement data held within the noise consultants' database will be used to model the severity of noise of piling operations over distance. These model outputs will be assessed in relation to audiograms and species density to quantify the potential level of effect on species during construction and maintenance works. The potential for effects will also be assessed with regard to the time of year so that levels of effect may be assumed with regard to different seasonal patterns of use.</p>

Potential Effect	Increased collision risk resulting in injury or death due to construction and maintenance effects (including vessel movements)
Survey/Study Proposed to Assess Effect	<p>Potentially sensitive receptors include:</p> <ul style="list-style-type: none"> - Regional marine mammal community <p>To determine the potential for disturbance and displacement, the following studies will be undertaken:</p> <p>Modelling of marine mammal density and distribution for the cable route study area Desk study of collision risk associated with cable construction and other vessel traffic.</p>
Method of Impact Assessment	<p>Marine mammal species density and distribution data will be used to model population densities across the site over time. The number of vessels required during construction and maintenance will be estimated over time. These data will be used to estimate collision risk with regard to the time of year so that levels of effect may be assumed with regard to different seasonal patterns of use. Where available, the results of the study will be cross-referenced against information on baseline traffic levels in the Moray Firth.</p>

Potential Effect	Potential reduction of the feeding resource due to effects on prey of noise and vibration, and habitat disturbance
Survey/Study Proposed to Assess Effect	<p>Potentially sensitive receptors include:</p> <ul style="list-style-type: none"> - Regional marine mammal community <p>To determine the potential for reduction of feeding resource, the following surveys and studies will be undertaken:</p> <p>Modelling of marine mammal density and distribution for the cable route study area Survey of marine benthic habitats (see section 0) Literature review of noise sensitive marine species audiograms (not including marine mammals) Desk-top study and noise modelling to determine zones of noise around piling operations (for substations) Literature study of marine mammal foraging habits and changes to marine trophic web associated with offshore power cables</p>
Method of Impact Assessment	<p>The potential for marine mammal species to be feeding within the site will be determined by assessing the distribution and density data of marine mammals within the site and relating this to literature accounts of species foraging habitats and habitat maps, along with the density and distribution of marine benthic organisms and fish within the cable route study area.</p> <p>The potential effect of construction and operation on habitats, benthic organisms and fish species will be determined using available information. In addition, noise propagation models will be used to model the severity of noise of piling operations over distance. The potential effect of increased noise on prey resources will be assessed where audiograms are available for noise sensitive fish and marine benthic species. These impact assessments will be used to assess the potential effect upon the foraging habits of marine mammals.</p> <p>The potential for effects will also be assessed with regard to the time of year so that levels of effect may be assumed with regard to different seasonal patterns of use.</p>

Site Specific Methodology

The following relates to the surveys for the EIA.

BEST PRACTICE GUIDANCE

At present, there is limited guidance from SNH or the Scottish Government on how to tackle the issue of deliberate disturbance, however the JNCC (2010) has produced guidance which provides an interpretation of what constitutes a 'significant' group and explains the 'disturbance offence' in greater detail. The guidance refers to the Habitats Directive Article 12 Guidance (European Commission, 2007) stating that in their view significant disturbance must have some ecological effect. Furthermore Marine Scotland has very recently issued further guidance on the protection of EPS from injury and disturbance (Marine Scotland, 2014) and this will be taken into consideration in the EIA.

The Seal Assessment Framework details an approach to assess the effects of noise from the construction of offshore wind farms on marine mammals. The University of Aberdeen, and marine mammals and underwater noise consultants working on behalf of MORL and BOWL developed this approach. This framework was accepted by the SNCBs. Full details can be found in the MORL ES (2012).

LITERATURE STUDY

A desktop literature search will be carried out to collect information on and inform impact assessments for marine mammals. These literature searches will include:

- Marine mammal species density and abundance within and around the cable corridor study area
- Audiograms for marine mammals and other noise sensitive species
- Marine mammal behaviours (including foraging)
- Effects associated with offshore power cables and the success of mitigation measures

Survey of Marine Mammal Density and Distribution

Details on survey methods used to collect data for the MORL Zone and the wider Moray Firth are provided in the MORL ES (MORL, 2012).

For the purposes of assessing the effects and potential mitigation of oil exploration operations in the Moray Firth, a three year programme of cetacean studies was commenced by the University of Aberdeen with funding from DECC, the Scottish Government, COWRIE and Oil and Gas UK. MORL have provided additional funding to the University of Aberdeen and the St Andrews Sea Mammal Research Unit (SMRU) to extend the examination of these data and undertake additional studies to establish a baseline of marine mammal activity in the region of the offshore wind farms and export cable route. Further details of these studies can also be found in the MORL ES (MORL, 2012).

OTHER SURVEYS/ASSESSMENTS TO BE USED TO IDENTIFY EFFECTS

- Underwater noise assessment is described in section 5.1.5.
- Habitat distribution surveys are described in section 5.1.2.
- Marine benthic surveys are described in section 5.2.2.
- Fish studies are described in section 5.2.3.

Cumulative and In-combination Impact Assessment & Survey Methodologies

The MFOWDG Cumulative Impacts Assessment Discussion Document (ERM, 2011) outlines the key cumulative effects that could potentially result from the proposed offshore wind farm developments (MORL and BOWL). The report states that increased operational activity may inflict multiple effects on the marine mammal

communities i.e. increased collision risk, decreased abundance of feeding resource due to noise, vibration or disturbance. The mammals may also be potentially directly affected by operational noise. There is a distinct lack of research on the effects of operational noise, and there is scope in the future for detailed analysis of this subject.

The approach outlined above for the OGS is also of relevance for the updated assessments for the OfTI and therefore a similar assessment methodology will be followed

Potential Mitigation Methods

Potential mitigation measures for effects to marine mammals include choice of installation techniques for OSP substructure and foundations and cables, the use of marine mammal observers and passive acoustic monitoring to ensure no marine mammal activity within a site prior to construction activities, the use of soft start procedures for piling activities and timing of construction activities.

The mitigation measures proposed for the final OfTI will be dependent upon the final design and the potential effects as determined by the EIA studies. Options of mitigation will be discussed with the relevant authorities.

5.2.5 Intertidal Benthic Ecology

Baseline Environment

Two potential cable landfall sites at Inverboyndie and Sandend are currently under consideration.

Both sites comprise sandy bays that are likely to allow relatively easy cable burial. There are no designated conservation areas on either landfall point. Sandend is a small bay with rocky outcrops either side, which are part of the Cullen to Stake Ness Coast SSSI, designated for its geological features. The beach itself, where the cable would be installed, is not within this SSSI. The landfall point at Inverboyndie also lies adjacent to, but not within, this SSSI.

Data Gaps

Site specific surveys will be required to determine the extent and distribution of intertidal species and habitat receptors including Annex I features.

Environmental Impacts Scoping

Based on available literature, the following are perceived to be the potential effects on intertidal benthic ecology as a result of the proposed transmission infrastructure:

Effect Description	Potential site specific effect	Potential cumulative and/or in-combination Effect
Release of contaminants bound in sediments	✓	✓
Temporary sediment disturbance due to export cabling	✓	✓

Since cable installation will be undertaken at low tide, there is not expected to be any significant direct release of suspended sediments into the water column from this activity. Also, whilst tidal inundation of the construction site may liberate some finer sediments, the effect and extent of this is considered to be very small. As such, we consider that the effects of temporary increases in suspended sediments and associated plume effects from installation of transmission infrastructure on intertidal benthic ecology can be scoped out at this stage.

Impact Assessment Methodology

For each of the potential effects described above a survey or study and method of impact assessment is described in the tables below. The potential effects listed have been developed from (a) relevant guidance notes, (b) the MORL ES (MORL, 2012) and (c) ESs published for other Round 1, 2, 3 and STW offshore wind farms.

Potential Effect	Release of contaminants bound in sediments
Survey/Study Proposed to Assess Effect	<p>Potentially sensitive receptors include:</p> <ul style="list-style-type: none"> - Trophic web <p>To determine potential contaminants bound in the sediments the following studies and surveys are proposed: Desk top study of historical contaminants within the surrounding seabed. If historical contamination is identified then it may be necessary, following discussions with statutory authorities to undertake chemical analysis of sediments</p>
Method of Impact Assessment	The data obtained during the desk study (and intertidal benthic survey) will be used to assess the likelihood of sediment contamination using standard EIA methodologies and comparison against Canadian Interim Sediment Quality Guidelines and CEFAS Action Levels In Dredged Materials.

Potential Effect	Temporary sediment disturbance due to export cabling
Survey/Study Proposed to Assess Effect	<p>Potentially sensitive receptors include:</p> <ul style="list-style-type: none"> - Intertidal benthic habitats and species <p>To determine temporary disturbance effects on intertidal habitats and associated communities the following studies and surveys are proposed: Intertidal biotope survey</p>
Method of Impact Assessment	Potential effects through direct habitat / community disturbance will be assessed via quantifying % of certain biotopes/habitats potentially affected, previous experience gained during the MORL ES (2012) and assessment of other Round 1, 2, 3 and STW offshore wind farms and standard EIA methodologies.

Site-specific Survey Methodology

BEST PRACTICE GUIDANCE

The following references provide best practice guidance for use in assessing effect upon benthic ecology:

- Davies *et al.* (2001). Marine Monitoring Handbook
- Wyn G, & Brazier P. 2001. Procedural Guideline No 3-1. In-situ intertidal biotope recording. In Marine Monitoring Handbook (pp 223-228).
- NMMP (2003). National Marine Monitoring Programme Green Book. V7.

- CEFAS (2004). Offshore Wind Farms: guidance notes for Environmental Impact Assessment in respect of FEPA and CPA requirements. Version 2
- DEFRA (2005) Nature conservation guidance on offshore wind farm development
- OSPAR (2008). OSPAR Guidance on Environmental Considerations for Offshore Wind Farm Development
- IEEM (2009). Guidelines for Ecological Impact Assessment in Britain and Ireland - Marine and Coastal Consultation document
- Hiscock K, (1996). Marine Nature Conservation Review: rationale and methods. Coasts and seas of the United Kingdom (MNCR series) JNCC

SURVEY DESIGN

A phase 1 biotope mapping survey is proposed at each of the potential landfall sites, to record and map habitats and associated biological communities (biotopes), together with descriptive accounts of environmental features and appropriate photography.

The survey area will encompass an area extending 200 m either side of the proposed offshore cable route at each proposed landfall site. In order to ensure access to the lowest reaches of the shore, surveying will be undertaken on low spring tide occasions. Work will commence just after high tide with surveyors working down the shore following the receding tide, with the aim to surveying the entire vertical range of the shore during one tide. Dig-over of sediments will be undertaken to look for conspicuous characterising species which will be identified *in-situ* and their abundance estimated using the SACFOR abundance scale (Hiscock, 1996).

Samples for determination of sediment chemistry will be transferred to a UKAS accredited laboratory for analysis (specific determinants to be agreed with Marine Scotland and SNH/JNCC).

DATA ANALYSIS

Field data will be used to support development of an intertidal biotope map showing the extent of ecological resources within the potential influence of the cable installation activities at each possible landfall location.

Cumulative and In-combination Impact Assessment & Survey Methodologies

The methodologies and potential survey requirements by which cumulative and in-combination effects will be assessed will be agreed with consultees. The cumulative and in-combination assessment methodology described in section 5.2.2 is also of relevance for this discipline.

Potential Mitigation Methods

Potential mitigation measures for marine benthic effects include micrositing the cable around features and choice of installation techniques.

The mitigation measures proposed for the final OfTI will be dependent upon the final design and the potential effects as determined by the EIA studies. Options of mitigation will be discussed with the relevant authorities.

5.2.6 Terrestrial Ecology

Baseline Environment

The onshore cable corridor search area runs through the north west of Aberdeenshire. This area comprises largely low-lying agricultural land which has been heavily modified by human activity. Within this largely agricultural landscape are a number of small settlements connected by a network of minor roads. Woodland habitats are sparsely scattered through the landscape and are a mix of semi-natural and plantation woodland. The River Deveron runs from south to north through the study area and enters the North Sea at Banff. The agricultural habitats which dominate the landscape have the potential to support good assemblages of farmland passerines, waders, geese, and badgers, while the network of watercourses may support otter, freshwater pearl mussel and water vole. Where settlements occur, the manmade structures have the potential to house bat roosts. Wooded areas may also be used by roosting bats where there are mature deciduous trees with suitable cracks and crevices. Red squirrel and pine marten may be found within the study area where mature, well-connected woodland is present, though this habitat is largely absent from the onshore cable corridor search area. Great crested newt are considered unlikely to be present given the absence of records in Aberdeenshire, however, they are known to be present around Inverness and therefore the possibility that they use the ponds located in the study area for breeding cannot be ruled out. Wildcat prefer marginal agricultural areas with moorland and woodland and as such are unlikely to be present within the cable corridor search area due to a lack of suitable habitat, though they may be present within the wider study area.

DESIGNATED CONSERVATION SITES

Scotland's suite of designated conservation sites, which provide statutory protection for flora and fauna, include:

- Internationally protected Ramsar sites;
- European protected Special Areas of Conservation (SACs) and Special Protection Areas (SPAs); and
- Nationally protected Sites of Special Scientific Interest (SSSIs).

The potential effect of the OnTI upon such protected sites and their features of interest require careful consideration. If sites of international or European importance are potentially affected, then SNH's advice will be required. If there is indication of a Likely Significant Effect (LSE) on international or European designated sites, then SNH/JNCC may advise the Competent Authority (Aberdeenshire Council) that an Appropriate Assessment is required.





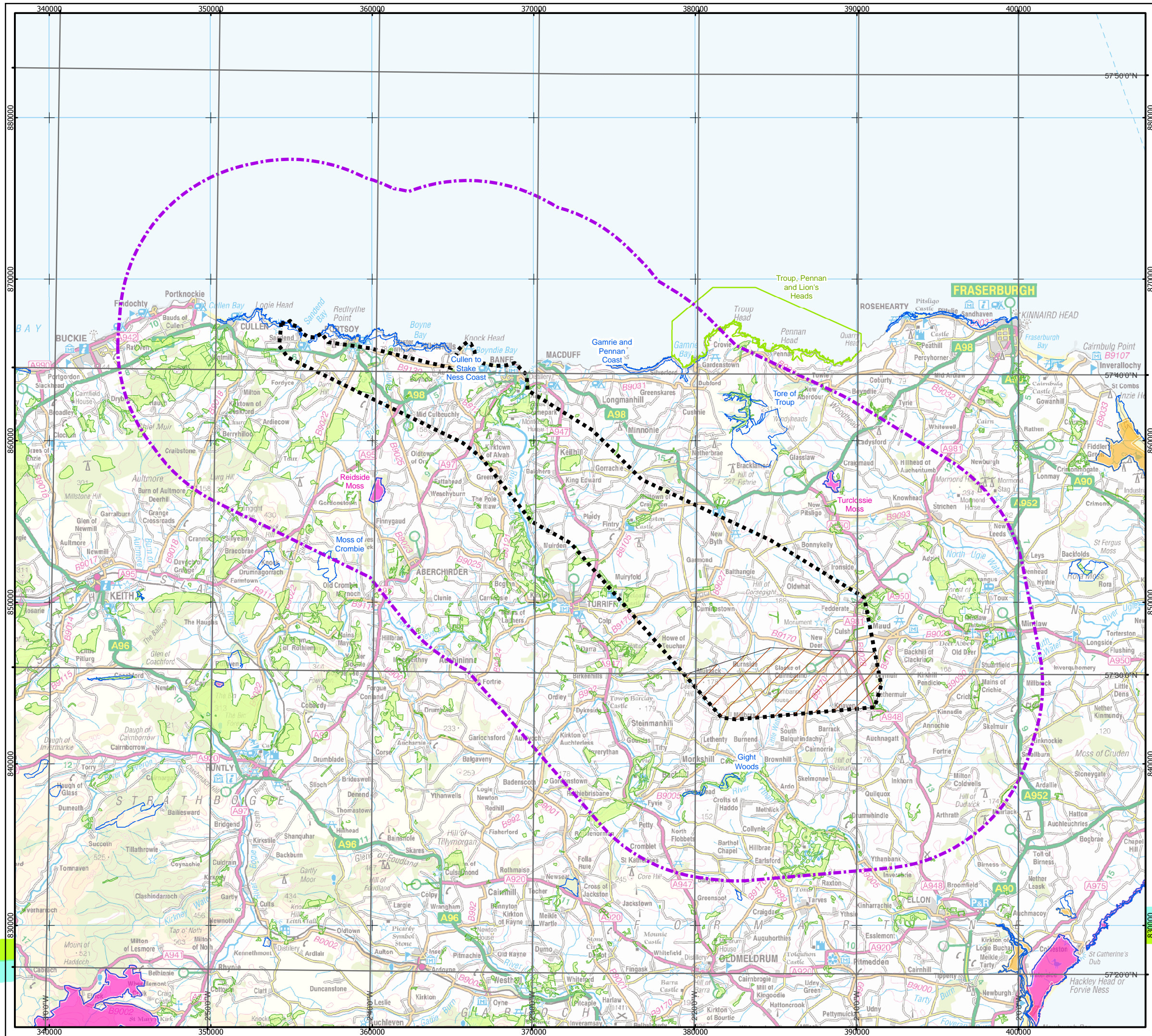



Within the vicinity (10 km) of the onshore cable corridor search area, the surrounding north Aberdeenshire landscape contains 10 designated conservation sites of terrestrial ecological interest (Figure 5-14, Table 5-4).

© Crown copyright and database rights [2013] Ordnance Survey [License Numbers: 1350462, 1326001, 1065958]. Contains Ordnance Survey data © Crown Copyright and database right [2014]. Moray Offshore Renewables Ltd © 2014. This document is the property of contractors and sub-contractors and shall not be reproduced nor transmitted without prior written approval.



Moray Offshore Renewables Ltd

KEY

-  Onshore Substation Search Area
-  Onshore Cable Corridor Search Area
-  Onshore Cable Corridor 10km buffer
-  Special Protection Area (SPA)
-  Site of Special Scientific Interest (SSSI)
-  Special Areas of Conservation (SAC)
-  Ramsar
-  Local Nature Reserve (LNR)
-  Ancient Woodland Inventory (AWI)

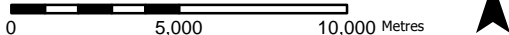
Horizontal Scale: 1:225,000 A3 Chart

Geodetic Parameters: British National Grid

Produced: KAG
 Reviewed: JF
 Approved: RH, SP

Date: 02/04/2014 Revision: A
 REF: 8460001-PSO0010-RPS-MAP-001

Fig 5-14 Designated Sites of Terrestrial Ecological Interest

Moray Offshore Renewables Ltd

Table 5-4: Sites Designated for Terrestrial Ecology Within 10 km of MORL's Onshore Cable Corridor Survey Area

Site	Minimum Distance From MORL's Onshore Cable Corridor Search Area	Relevant SAC/SPA Qualifying Feature or SSSI Notified Feature
Cullen to Stake Ness Coast SSSI	Adjacent to MORL's onshore cable landfall point at Sandend	<ul style="list-style-type: none"> - Lowland dry heath - Springs (including flushes) - Saltmarsh - Shingle
Gight Woods SSSI	3.33 km	<ul style="list-style-type: none"> - Upland mixed ash woodland - Upland oak woodland
Tore of Troup SSSI	3.75 km	<ul style="list-style-type: none"> - Upland mixed ash woodland - Upland birch woodland - Upland assemblage (mosaic habitat)
Gamrie and Pennan Coast SSSI	3.88 km	<ul style="list-style-type: none"> - Breeding guillemot - Breeding puffin - Breeding kittiwake - Breeding razorbill - Breeding seabird colony - Breeding fulmar - Breeding gannet - Maritime cliff habitat
Reidside Moss SSSI	4.16 km	<ul style="list-style-type: none"> - Raised bog
Reidside Moss SAC	4.16 km	<ul style="list-style-type: none"> - Active raised bog - Degraded raised bog
Turclossie Moss SAC	4.62 km	<ul style="list-style-type: none"> - Active raised bog - Degraded raised bog
Turclossie Moss SSSI	4.62 km	<ul style="list-style-type: none"> - Raised bog
Troup, Pennan and Lion's Heads SPA	6.84 km	<ul style="list-style-type: none"> - Breeding seabird assemblage, 150,000 seabirds of 9 species - Internationally important breeding guillemot, 44,600 individuals, 4% of the British population - Internationally important breeding black-legged kittiwake, 31,600 pairs, 6% of British population - Breeding fulmar, 4,400 pairs - Breeding herring gull, 4,200 pairs, 2% of British population - Breeding razorbill, 4,800 individuals.
Moss of Crombie SSSI	9.61 km	<ul style="list-style-type: none"> - Active raised bog

Data Gaps

Site specific surveys will be required to determine the extent and distribution of species and habitat receptors, including Annex I habitats and species.

Environmental Impacts Scoping

Based on available literature, Table 5-5 below indicates what are perceived to be the potential effects on terrestrial ecology as a result of the proposed OnTI:

Table 5-5: Potential Effects on Terrestrial Ecology (Excluding Ornithology) as a result of the Proposed OnTI

Effect Description	Potential site specific effect	Potential cumulative and/or in-combination Effect
Disturbance leading to displacement of terrestrial and freshwater fauna (activities associated with cable burying/ onshore substations construction, repair/maintenance and decommissioning)	✓	✓
Loss of terrestrial habitat (and associated potential loss of breeding and foraging habitat) through construction of onshore substations, and (temporary) loss due to onshore export cable laying activities	✓	✓
Potential release of pollutants during construction activities e.g. from accidental spillage/leakage affecting, including any associated fauna	✓	✓
Potential injury or death of fauna during activities associated with cable burying/ substations construction, repair/maintenance and decommissioning	✓	✓

Impact Assessment Methodology

For each of the potential effects described above a survey or study and method of impact assessment is described in the tables below.

Potential Effect	Disturbance leading to displacement of terrestrial and freshwater fauna (activities associated with cable burying/ onshore substations construction, repair/maintenance and decommissioning)
Sensitive Receptors	Potential sensitive receptors include: <ul style="list-style-type: none"> - Regional, national and international terrestrial and freshwater faunal communities
Survey/Study Proposed to Assess Effect	To determine potential for disturbance and displacement, the following surveys and studies will be undertaken: <ul style="list-style-type: none"> - Desktop study to identify the existing fauna in the onshore cable corridor search area, including wintering birds, coastal birds and protected species of conservation concern - Consultation with SNH to inform the requirement for freshwater pearl mussel surveys - Breeding bird surveys - Wintering bird surveys - Bat roosting and habitat foraging suitability survey - Otter survey - Water vole survey - Badger survey - Great crested newt habitat suitability survey - Red squirrel habitat suitability survey - Pine marten habitat suitability survey - Wildcat habitat suitability survey
Method of Impact Assessment	Using the data gathered during the desk based assessment, consultation process and field surveys, an assessment will be made of the likely effects of disturbance and displacement on terrestrial/freshwater fauna. This assessment will consider the effects on receptor species at the local population level.

Potential Effect	Loss of terrestrial and freshwater habitat (and associated potential loss of breeding and foraging habitat) through construction of onshore substations, and (temporary) loss due to onshore export cable laying activities
Sensitive Receptors	Potential sensitive receptors include: <ul style="list-style-type: none"> - Regional, national and international habitat communities - Regional, national and international terrestrial and freshwater faunal communities
Survey/Study Proposed to Assess Effect	To determine potential for habitat loss, the following surveys and studies will be undertaken: <ul style="list-style-type: none"> - Desk top study to identify the existing fauna in the Proposed Development, including wintering birds, coastal birds and protected species of conservation concern - Consultation with SNH to inform the requirement for fresh water pearl mussel surveys - Breeding bird surveys - Wintering bird surveys - Phase 1 Habitat Survey - Bat roosting and habitat foraging suitability survey - Otter survey - Water vole survey - Badger survey - Great crested newt habitat suitability survey - Red squirrel habitat suitability survey - Pine marten habitat suitability survey - Wildcat habitat suitability survey
Method of Impact Assessment	Using the data gathered during the desk based assessment, consultation process and field surveys, an assessment will be made of the likely effects of habitat loss on terrestrial/freshwater plant communities and fauna. This assessment will consider the effects on receptor species at the local population level.

Potential Effect	Potential release of pollutants during activities associated with onshore export cable burying/ onshore substations construction, repair/maintenance and decommissioning e.g. from accidental spillage/leakage affecting freshwater habitats and associated fauna
Sensitive Receptors	Potential sensitive receptors include: <ul style="list-style-type: none"> - Regional, national and international freshwater habitat communities - Regional, national and international freshwater faunal communities
Survey/Study Proposed to Assess Effect	To determine potential for disturbance and displacement, the following surveys and studies will be undertaken: <ul style="list-style-type: none"> - Desk top study existing fauna and flora in and around freshwater and wetland habitats - Consultation with SNH to inform the requirement for fresh water pearl mussel surveys - Phase 1 habitat survey - Otter survey - Water vole survey - Great crested newt habitat suitability survey
Method of Impact Assessment	The potential effect of the release of pollutants will be assessed in the EIA with reference to the Hydrology, Geology and Hydrogeology Chapter using standard EIA methodologies and previous literature, taking consideration of the likely mitigation measures. This assessment will consider the effects on receptor species at the local population level.

Potential Effect	Potential injury or death of fauna during activities associated with onshore export cable burying/ onshore substations construction, repair/maintenance and decommissioning
Sensitive Receptors	Potential sensitive receptors include: <ul style="list-style-type: none"> - Regional, national and international faunal communities
Survey/Study Proposed to Assess Effect	To determine potential for death or injury to fauna the following surveys and studies will be undertaken: <ul style="list-style-type: none"> - Desk top study to identify the existing fauna in the proposed development area, including wintering birds, coastal birds and protected species of conservation concern - Consultation with SNH to inform the requirement for fresh water pearl mussel surveys - Breeding bird surveys - Wintering bird surveys - Bat roosting and habitat foraging suitability survey - Otter survey - Water vole survey - Badger survey - Great crested newt habitat suitability survey - Red squirrel habitat suitability survey - Pine marten habitat suitability survey - Wildcat habitat suitability survey
Method of Impact Assessment	Using the data gathered during the desk based assessment, consultation process and field surveys, an assessment will be made of the likely effects of death and injury on terrestrial/freshwater fauna. This assessment will consider the effects on receptor species at the local population level.

Site Specific Methodology

BEST PRACTICE GUIDANCE

- SEPA's Pollution Prevention Guidelines:
- PPG 1 General guide to the prevention of pollution ;
- PPG 2 Above ground oil storage tanks ;
- PPG 5 Works and maintenance in or near water;
- PPG 8 Safe storage and disposal of used oils ;
- SNH, 2001. Otters and Development;
- SNH, 2001. Badgers and Development; and
- Forestry Commission Scotland. Forest Operations and Red Squirrel in Scottish Forests. FCS Guidance Note 33, November 2006.

No specific guidance has been set out by SNH for ecological survey of land proposed for underground cable construction. As such, SNH's guidance document on assessment of significance of effects from onshore wind farms in areas outside designated sites (SNH, 2006a) has been referred to instead. This guidance provides advice on assessing effects on Annex I birds in the wider countryside using Natural Heritage Zone (NHZ) populations. A second SNH document referred to provides guidance on European and national legislation and government policy (SNH, 2006b), which supports the former document by detailing the legislative requirements underpinning the assessment of significance of effects in areas outside designated sites.

As MORL's onshore export cable will be underground, there is no risk of collision with birds. As such flight activity surveys are not considered necessary and have not been included in the proposed suite of surveys and are **scoped out**.

PROTECTED SPECIES AND SPECIES OF CONSERVATION CONCERN SURVEY (DESK STUDY)

A detailed desk study will be carried out to assess the presence of:

- European Protected Species, protected under the Habitats Directive and Habitats Regulations;
- UK Protected Species, protected under the Wildlife and Countryside Act;
- Species of national conservation concern, protected by the Protection of Badgers Act or listed on the Scottish Biodiversity List (SBL); and
- Species of local conservation concern, listed on the Northeast Scotland LBAP.

Data will be sought from:

- Aberdeenshire Council;
- SNH;
- Sitelink (www.snh.org.uk/snhi);
- National Biodiversity Network (NBN) Gateway (www.searchnbn.net)
- SWT;
- North East Scotland Biological Recording Centre (NESBReC);
- North East Scotland Bat Group;
- Local Amphibian and Reptile Group (ARG)
- Scottish Badgers;
- BSBI; and
- Forestry Commission Scotland (if their land occurs within the proposed cable route study corridors).

In addition, species distribution maps will be consulted to assess which species will require consideration in assessment of potential effects from the construction/operation/decommissioning of the proposed cable route and substation.

BREEDING BIRD SURVEY

This survey will be designed to document the presence of breeding birds within the cable corridor search area and substation sites. The data generated will allow estimation of the numbers and locations of breeding territories.

The breeding bird survey will be carried out within the onshore cable route corridor search area and will be flanked by a 250 m buffer.

Surveyors will walk each transect and record all ornithological activity (species and behaviour) within approximately 250 m to the left and right. Recordings will be made using standard BTO notation directly onto zoomed-in maps of individual 2 km² tiles, on Ordnance Survey 1:10,000 basemaps, provided to surveyors on A3 sheets. Standard Common Bird Census (CBC) methodology will be employed. Where moorland habitats are encountered, the Brown and Shepherd method will be used. For rarer species it is particularly important that locations are recorded as accurately as possible. Further, where possible an effort will be made to record whether rare birds that are not recorded simultaneously are different birds or separate observations of the same bird. Such information will greatly enhance desk-based analysis.

Three visits will be carried out between April and June 2014, between dawn and midday throughout. Surveys will be carried out in good visibility, avoiding persistent rain or fog, excessive cold or heat and wind exceeding Beaufort force 4.

The field records will be digitised using GIS software, and the resulting output from the three visits analysed to identify breeding territories. Birds will be identified as 'breeding' if the following are met:

For all birds:

- presence of nest, eggs and/or chicks;
- alarm calling indicative of nest, young or territory;
- displaying or song-flighting;
- distraction display;
- birds aggressively defending territories; or
- birds are seen carrying food to nest or young.

For divers and ducks:

- birds showing secretive behaviour; or
- presence of pairs, lone males, small groups of males chasing females (ducks only).

For all raptors:

- if a pair are apparently attached to a territory.

For partridge:

- if a pair are recorded;
- males in song flight; or
- males in territorial behaviour.

For all gulls:

- numbers of pairs are counted

For all passerines:

- birds singing or alarm calling.

In the absence of these indicative behaviours, a pair of birds observed together in suitable habitat will be considered to be a breeding pair. All other records will be considered to be non-breeding birds. Within visits, multiple records of the same species within 500 m for waders, or 200 m for passerines, will be considered to be birds of the same pair. Multiple records separated by more than the relevant distance will be recorded as different pairs. Exceptions may occur where surveyors are able to identify in the field that that multiple records are birds of different pairs, or vice versa. All pertinent data will be recorded on field maps to indicate whether this is the case.

WINTER BIRD SURVEY

This survey will be designed to document the presence of wintering birds within the onshore cable corridor search area and substation sites. The data generated will identify the locations of any noteworthy aggregations of, or habitats for, wintering species that are listed on:

- Annex 1 of the EU Birds Directive; or
- Schedule 1 of the Wildlife and Countryside Act, 1981 (as amended).

Or species with a noteworthy conservation status, specifically those listed as:

- Red or Amber listed Birds of Conservation Concern;
- Priority Species within the UK Biodiversity Action Plan; or
- Those included on the Scottish Biodiversity List.

The survey method will involve walking a pre-determined route so that, during survey visits, all points within the survey area are approached to within 200 metres. The survey area will be defined as the onshore corridor working width, 50 m in width, plus a 250m buffer either side. Surveyors may combine short watches during the walked route covering landscape features of potential ornithological importance (e.g. lagoons, burns, valleys, plantations etc.). The location and activity of target species will be recorded on 1:10,000 OS maps using standard BTO notation. The data will be digitised for analysis and presentation.

COASTAL BIRD SURVEYS (DESK STUDY AND FIELD SURVEY)

A desk study will be undertaken to identify any coastal bird assemblages of note which may occur within the study area. This would firstly consist of a review of the Wetland Bird Survey (WeBS) data that covers the wintering species and is held by the British Trust for Ornithology. A review of specific count sector data for the last 5 years would be undertaken. Breeding season data would also be extracted from the JNCC Seabird 2000 (S2K) database and should give a very clear picture of the suitability of the proposed land fall points for breeding seabirds. The JNCC maps produced for oil spill contingency planning will also be consulted, as these give indications of known concentrations of wildfowl and waders, plus important areas of coastal habitat.

SNH will be consulted on the information from the desk in order to identify the need for site specific surveys. Should surveys of coastal bird be required, they would utilise both WeBS and S2K bird survey methodologies.

PROTECTED SPECIES SURVEY

The onshore cable corridor search area (incorporating substation location options) plus a 250 m buffer will be surveyed for field evidence of the following protected species. Where suitable habitat is found with the potential to support the following species, this will also be recorded:

- Bats (location of likely roost sites and suitable foraging habitat only);
- Otter;
- Great crested newt (initial habitat assessment only using the Habitat Suitability Index [HSI] described in Oldham et al. 2000);
- Pine marten;
- Red squirrel;
- Water vole;
- Wild cat and
- Badger.

Subject to consultation with SNH habitat suitability assessments for freshwater pearl mussel surveys will also be undertaken within the 250 m survey buffer.

Sightings or field evidence of protected species will be recorded using target notes, photographs and GPS coordinates. Field signs recorded will include prints, mammal paths, droppings, resting sites (including holts/couches/dreys/burrows/setts/dens) and feeding remains.

The need for more detailed surveys to inform the impact assessment for select species will be informed by the initial consultation process and findings of the survey suite outlined above.

PHASE 1 HABITAT SURVEY

The Phase 1 survey will identify habitat types and the vascular plants of each habitat in accordance with the methods described in the Joint Nature Conservation Committee (JNCC, 2010). Areas of particular botanical interest (e.g. habitats listed on Annex 1 of the Habitats Directive – namely areas of blanket bog, wet modified bog, marshy grassland and acid grassland) will be noted during the Phase 1 Habitat. In addition, GPS coordinates and target notes will be undertaken for all plants protected under Schedule 8 of the Wildlife and Countryside Act and plants of national nature conservation importance.

The Phase 1 Habitat Survey will be undertaken between May-August and will cover the onshore cable corridor search area and substation sites plus a 250 m buffer.

During the Phase 1 Habitat Surveys, the presence of invasive plant species will be recorded. Invasive species of particular concern are Japanese knotweed (*Fallopia japonica*), Himalayan balsam (*Impatiens glandulifera*) and giant hogweed (*Heracleum mantegazzianum*). This will ensure that the location of these plants is identified prior to construction, allowing special measures to be implemented to attempt to prevent their spread into the wider countryside, as required under the Wildlife and Countryside Act 1981 (as amended).

FRESHWATER PEARL MUSSEL SURVEY

Following consultation with SNH, it may be necessary to undertake freshwater pearl mussel surveys to establish if this species is present within the survey area.

Initially, habitat with potential to support freshwater pearl mussels will be identified. This will be carried out using a standard habitat scoping study survey form, for which surveyors will assess watercourse conditions, specifically, substrate suitability, algal cover, presence of salmonids, depth, width, gradient, speed of flow and anthropogenic effects (e.g. pollution). The general conditions used to determine habitat with potential to support freshwater pearl mussel will follow standard SNH guidelines and will also be based on professional judgement.

The habitat scoping study survey form will assess the river's potential to support freshwater pearl mussel according to the following:

- Mussels present (dead or alive);
- Suitable;
- Sub-optimal; and
- Unsuitable.

Watercourses with mussels present, or graded as suitable or sub-optimal, will be subject to intensive survey for the species. If there is any doubt over whether the watercourse may support freshwater pearl mussel, then it will be intensively surveyed.

Surveyors will make an assessment of semi-natural habitats during progression of the Phase 1 Habitat Survey, so that the most important examples of each habitat can be identified. The assessment will be based on primary evaluation criteria outlined by Ratcliffe (Ratcliffe, 1977), and will involve consideration of each habitat's naturalness, size, rarity, diversity and position in an ecological unit.

Where a habitat type is considered important or where a combination of habitats will be considered to be important, they will be listed as Important Habitat Areas (IHAs). A National Vegetation Classification (NVC) survey will also be undertaken in these areas following the methodology outlined by Rodwell (2006).

Cumulative and In-combination Impact Assessment & Survey Methodologies

The assessment will also consider the cumulative effect of the effects of the onshore cable corridor search area and substations in combination with those associated with all other large scale planned developments within 5 km. Large scale developments to be incorporated in the cumulative assessment are likely to include any proposed wind farms, substations, cable routes and mineral sites.

Potential Mitigation Methods

Potential mitigation measures for terrestrial ecology effects that may be incorporated into the EIA where appropriate include:

- Micrositing the onshore substations and cable route to avoid ecologically sensitive areas;
- Pre-construction checks for mobile species, such as badger otter and water vole to update the information in the EIA;
- Environmental clerk of works (ECoW) retained to manage the ecological issues during the construction phase; and
- Working areas clearly demarked and restricted to cause minimum effects on sensitive habitats.

The mitigation measures proposed will be specific to the final design of the project and presence of sensitive species and habitats, as identified during the survey suite identified above.

5.2.7 Ornithology (Offshore)

Baseline Environment

The Moray and Aberdeenshire coasts and offshore waters are host to internationally-important numbers of breeding seabirds and over-wintering waterbirds (e.g. seaducks, diving ducks, divers, grebes and waders), and are important for feeding during the spring and autumn migrations of species that breed at high latitude. As recognition of this there are a number of sites in this area which are designated for their ornithological interests. These include international-level Special Protection Areas (SPAs) and Ramsar sites, and national Sites of Special Scientific Interest (SSSIs).

The Moray and Aberdeenshire coastlines are important areas for seabirds, supporting internationally- and nationally-important breeding populations of fulmar, shag, herring gull, kittiwake, guillemot and razorbill. The Moray and Aberdeenshire coasts are also recognised as being important sites for seaduck. Designated sites with species which have the potential to forage within the cable route study area are:

- Troup, Pennan & Lion's Head SPA
- Gamrie and Pennan Coast SSSI
- Rosehearty to Fraserburgh Coast SSSI
- Loch of Strathbeg SPA
- Buchan Ness to Collieston Coast SPA
- Bullers of Buchan Coast SSSI
- Collieston to Whinnyfold Coast SSSI.

The details on the designating features for each of the above sites are listed in Table 5-4 (section 5.2.6) and shown in Figure 5-14.

Due to the nature of the potential risks posed by the construction of an offshore export cable and OSPs the target species for this assessment will be those which may forage within the study area. This will therefore exclude species (such as geese, swans and waders) that will only occur in the study area in flight, either on migration or commuting between foraging/roosting/loafing areas. The waters of the outer Moray Firth and the nearshore waters off the Moray and Aberdeenshire coasts are important feeding areas for seabirds and seaduck (Tasker, 1996). Of the seabirds, fulmars are widely distributed in the offshore cable route study area throughout the year, whilst gannet, kittiwake and auk numbers peak during the summer or autumn. The surrounding coastal waters are of particular year-round importance for shags and herring gulls (DTI, 2004; DECC, 2009b). Table 5-6 summarises the seasonal seabird distribution and abundance in the OfTI study area.

Table 5-6: Summary of seasonal seabird distribution and abundance in the OFTI study area.

Month	Distribution & Abundance
January/February	Guillemots are abundant in the Moray Firth throughout the winter. The same is also the case for fulmar, which start to form territories at colonies from January. Numbers of herring and great black-backed gulls peak around this time, particularly in coastal areas.
March	Many seabirds, including gannet, kittiwake, herring gull, guillemot, razorbill and puffin, return to the vicinity of their colonies in early Spring. The highest densities of fulmar are also around the main breeding areas. Herring and great black-backed gulls remaining in area include breeding birds.
April	Egg-laying will commence towards the end of this month for some seabirds, such as gannet and the auks. Foraging will take place both close to colonies and further offshore. Fulmar, gannet and kittiwakes remain will widely distributed areas across the area, with the large densities found near colonies. Arctic and common terns will migrate through the area en route to breeding colonies.
May	Egg-laying will continue for those species also underway, and will commence for the remaining seabirds, such as fulmar and kittiwake. Birds can still forage at distances further from the colonies than during chick rearing (e.g. auks up to 60 km and kittiwakes up to 120 km).
June	Peak of breeding season, with chicks starting to hatch for most species. The majority of seabirds are in coastal areas, e.g. most breeding guillemots do not feed further than 30 km from their breeding site, and razorbill forage closer to shore than guillemots. At the end of month guillemot chicks start to leave colonies and disperse offshore.
July/August	The nesting season for most seabird species ends by mid-July, and adult and juvenile birds start to move south to wintering grounds or move to areas where they form moulting flocks. In July/August offshore areas will support larger densities of birds than at any other time of the year. Young fulmar and gannet start to fledge in August.
September	Distribution of auks spreads outwards into North Sea: guillemot will remain in near- and offshore areas but the majority of puffin and razorbill will be further offshore. Numbers of shearwaters (Manx and sooty) and skuas (mainly great and Arctic) will peak around this time. Fulmars will continue to be numerous.
October/November/December	Seabirds such as guillemot and fulmar continue to be abundant throughout the winter. Smaller numbers of other auks, gannet and kittiwake may also be present. The numbers of herring and greater black-backed gulls will increase during the winter.

Source: DECC (2009b), Mudge & Crooke (1986), Tasker & Pienkowski (1987), Skov *et al.*, (1995)

DATA FROM MORL ES (2012) BIRD SURVEYS

Between April 2010 and March 2012, 28 boat-based ornithological surveys were undertaken to gather information on bird activity to inform the EIA for the EDA of the Zone, as detailed in MORL's ES (MORL, 2012).

The most commonly recorded species were guillemot, kittiwake, fulmar, razorbill, gannet, puffin, Arctic tern, great black-backed gull and herring gull. Most of these species were recorded in highest numbers between the spring to late summer period. Several species have been recorded less frequently, including sooty shearwater, Manx shearwater, storm petrel, Arctic skua, great skua, lesser black-backed gull and little auk.

AERIAL DATA

Seven aerial surveys were undertaken over the MORL Zone in 2009 (May, June August, November and December) and 2010 (two in February). The first three surveys were undertaken by HiDef Aerial Surveying, and the remaining surveys by WWT Consulting. The surveys covered the entire Zone plus a 4 km buffer.

The key findings from these data for the MORL development area are:

- The most frequently recorded bird species / species groups in this area were auks, with high numbers of fulmar, kittiwake and other gulls also recorded.
- Other bird species recorded within the Moray Firth site included gannet, along with very low numbers of divers, Leach’s petrel, Arctic skua, great skua, and unidentified terns.
- Seasonal variations in bird numbers present within the Moray Firth site included: increasing numbers of fulmar in November compared to other months; highest numbers of gannet and kittiwake in June and August, with low numbers during the winter; and higher numbers of auks during May and June compared to the winter.

In addition, aerial surveys were undertaken during the summer of 2011 covering the significant majority of the proposed offshore cable corridor. The results of these surveys indicated very low densities of great black-backed gull, kittiwake, fulmar and razorbill across the survey area. Guillemot and puffin densities were patchy across the survey area with relatively low numbers of birds within the EDA and proposed offshore cable corridor when compared with the densities across the overall survey area.

Data Gaps

There is an extensive amount of ornithological data for the Moray and Aberdeenshire offshore area, including survey data collected to support the MORL offshore wind farm (MORL, 2012). No further data are expected to be collected to inform the offshore ornithology impact assessment for the consent application.

Environmental Impact Scoping

The predicted effects listed below are based on similar experiences with previous offshore cable routes and OSPs around the UK coast and in European waters in general.

Effect Description	Potential site specific effect	Potential cumulative and/or in-combination Effect
Indirect habitat loss and displacement from feeding areas as a consequence of disturbance of marine prey	✓	✓
Disturbance during construction and decommissioning	✓	✓

© Scottish National Heritage
 © Seazone Solutions Limited, 2005, [012009.001, 022011.009]. This product includes mapping data licensed from Ordnance Survey (Great Britain) with the permission of HMSO. © Crown Copyright, 2006. All rights reserved.
 Moray Offshore Renewables Ltd © 2014. This document is the property of contractors and sub-contractors and shall not be reproduced nor transmitted without prior written approval.

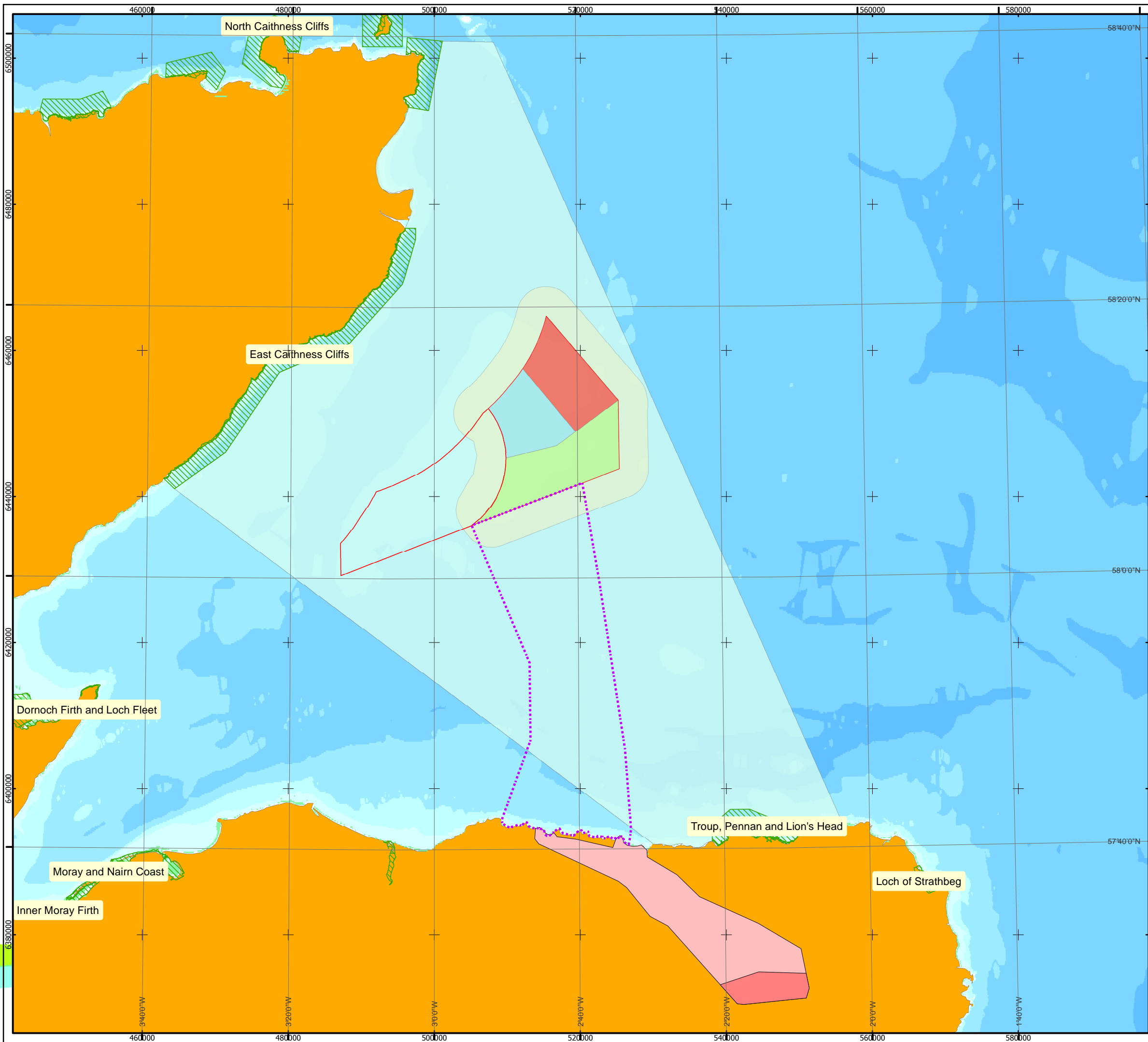

Moray Offshore Renewables Ltd

- KEY**
- Phase 1 Boundary (4km Buffer)
 - Additional Survey Area
 - SPAs (Moray Firth)
 - Offshore Cable Corridor
 - Onshore Substation Search Area
 - Onshore Cable Corridor Search Area
 - The Zone

Horizontal Scale: 1:500,000 A3 Chart

Geodetic Parameters: WGS84 UTM Zone 30N

Produced: RH
 Reviewed: PM
 Approved: SP

Date: 07/04/2014 Revision: B
 REF: 8460001-PSO0010-MOR-MAP-043

Fig 5-15 Offshore Bird Survey Overview

Moray Offshore Renewables Ltd

Site-specific Impact Assessment Methodology

For each of the potential effects described above the method of impact assessment is described in the tables below.

Potential Effect	Indirect habitat loss and displacement from feeding areas as a consequence of disturbance of marine prey
Survey/Study Proposed to Assess Effect	<p>Potentially sensitive receptors include:</p> <ul style="list-style-type: none"> - Regional, national and international bird communities <p>To determine the potential for habitat loss and effects to prey, the following information will be used:</p> <p>Seabird density and distribution data from Round 3 Zone 1 boat-based and aerial surveys.</p> <p>Survey of marine benthic habitats (see section 0)</p> <p>Information on fish species audiograms to be collected through desk-top study</p> <p>Desk-top study and noise modelling to determine zones of noise around piling operations (for OSPs)</p> <p>Literature study of bird species foraging habits and changes to marine trophic web associated with offshore power cables</p>
Method of Impact Assessment	<p>The potential for bird species feeding within the cable route corridor and OSP locations will be determined by assessing the distribution, density and behaviour data of birds within the area and relating this to literature accounts of species foraging habitats and habitat maps and the density and distribution of marine benthic organisms and fish.</p> <p>The potential effect of construction and maintenance on habitats, benthic organisms and fish species will be determined using available information. The potential effect of increased noise on prey resources will be assessed where audiograms are available for noise sensitive fish and marine benthic species. These impact assessments will be used to assess the potential effect upon the foraging habits of bird species.</p> <p>The potential for effects will also be assessed with regard to the time of year so that levels of effect may be assessed with regard to different seasonal patterns of use.</p>

Potential Effect	Disturbance during construction, maintenance and decommissioning Disturbance may be initiated by vessels and construction/maintenance activities
Survey/Study Proposed to Assess Effect	<p>Potentially sensitive receptors include:</p> <ul style="list-style-type: none"> - Regional, national and international bird communities <p>To determine the potential for disturbance, the following studies will be used:</p> <p>Survey of bird species density and distribution– boat-based and aerial surveys.</p> <p>Review of disturbance on birds arising from OfTI construction, maintenance and decommissioning activities</p>
Method of Impact Assessment	<p>Bird species density, distribution and behavioural data will be collated to inform likely population densities across different parts of the cable route study area in different seasons. The effect of the anticipated construction, maintenance and decommissioning activities will be assessed in relation to these baseline data. The potential for effects will also be assessed with regard to the time of year so that levels of effect may be assumed with regard to different seasonal patterns of use.</p>

Cumulative and In-combination Impact Assessment Methodologies

The cumulative and in-combination impact assessment will be based on guidance issued by COWRIE (King *et al.*, 2009) which uses 'key features' tables to identify a list of species which will be most at risk of cumulative and in-combination effects.

Potential Mitigation Methods

Potential mitigation measures for effects to birds include: micro-siting of the cable to avoid sensitive habitats; choice of construction techniques; and use of standard vessel routes.

5.2.8 Designated Sites

This will provide an overview of the statutory and non-statutory protected sites within the vicinity of the TI, or which could be potentially affected by the TI. These designated sites are protected under European Directives and/or UK/Scottish legislation. Additional non-statutory designated sites are also considered.

A description of designated sites relevant to the TI will be provided in the baseline section of the ES with impact assessment included in the relevant disciplines.

5.3 Human Environment

5.3.1 Data Sources

The following data sources provide information on the existing human environment at the current time:

General:

- Marine Scotland Science
- UK Offshore Energy Strategic Environmental Assessment, DECC
- SEA 5: Strategic Environmental Assessment of parts of the northern and central North Sea to the east of the Scottish mainland, Orkney and Shetland, DTI
- Economic Assessment of Short Term Options for Offshore Wind Energy in Scottish Territorial Waters: Costs & Benefits to Other Marine Users and Interests (Marine Scotland)
- Department of Energy and Climate Change (DECC)
- Scottish Government
- The Crown Estate
- The Beatrice Demonstrator project Environmental Statement
- Renewable UK
- Scottish Natural Heritage (SNH)
- Joint Nature Conservation Council (JNCC)
- The National Trust
- Local Planning Authorities
- Universities
- MORL ES
- BOWL ES

Additional sources for:

Commercial Fisheries –

- Scottish Fishermen’s Federation
- National Fishermen’s Federation Organisation
- Regional SFF affiliated fishermen’s associations and produced organisations
- Local non-affiliated fishermen’s associations, groups and individual skippers
- Marine Scotland District Fisheries inspectors
- Local harbourmasters
- Marine and Fisheries Agency
- SeaFish
- Fisheries Society of the British Isles
- Association of Salmon Fisheries Boards
- Local ports merchants and agents
- UK Oil and Gas (UKO&G)
- International Council for Exploration of the Seas
- EU Fisheries Committee Publications and Data Sets (Europa & Eurolex)
- Foreign National Fisheries Agencies (identified through the course of the EIA)
- ScotMap

Commercial Navigation –

- Chamber of Shipping
- Marine and Coastguard Agency
- Northern Lighthouse Board
- Royal National Lifeboat Association
- Pilotage Association
- Forth Ports and other local port operators

5.3.2 Commercial Fisheries

Baseline Environment

Assessment of the fisheries baseline provided below is based primarily upon fisheries data (MMO Fisheries Statistics, 2000-2009) collected for all commercial fishing vessels by ICES rectangles, and a dataset produced by Marine Scotland Science (MSS) showing the distribution of commercial fishing landings from vessels exceeding 15 m in length, by weight and value.

ICES statistical rectangles are currently the smallest area of statistical units used for the collation of fisheries data. Rectangle boundaries align to 1° longitude and 30’ latitude and for the most part have sea areas equating to approximately 900 nm. The proposed TI is located within ICES rectangles 45E7 and 44E7. The very large sea area these rectangles comprise relative to the OfTI area and the potential of discrete, small-scale fisheries to occur is noted.

All EU fishing vessels over 15 m in length are required to be satellite monitored (Vessel Monitoring System, VMS), their positions recorded on a 2 hourly basis. The MSS dataset links VMS data to landings data. As a result of vessels under 15 m not currently being required to be monitored, the activity of this fleet may not be represented in this dataset.

Scallops account for over half of the landings, by value, in offshore rectangle 45E7, and *Nephrops* and demersal fish species (haddock and monkfish principally) comprise a third of the landings by value. *Nephrops* are the

principal species landed in 44E7, accounting for almost half of the total landings by value, with squid, scallops and haddock and monkfish comprise the large majority of the remaining landings, by value.

Scallops are targeted by vessels towing toothed dredges attached to beams towed over the seabed. *Nephrops* are a burrowing shellfish targeted by both demersal trawlers and potting (creel) vessels. The principal methods for targeting demersal species such as haddock and monkfish are demersal trawlers and Scottish seines (flydraggers). Squid is principally targeted by the demersal trawl fleet using modified gear, or alternatively by 'jiggers' (a series of barbed lures attached to a vertically dropped line which is 'jigged' up and down). Crab and lobster are caught using baited pots (creels) set on the seabed.

The scallop fishery predominantly occurs in areas of the Smith Bank, and inshore along the south coast of the Moray Firth. The scallop fishery is cyclical and grounds are often left to recover from intensive fishing periods while the fleet targets grounds elsewhere. The *Nephrops* fishery is concentrated in muddier substrates in the southern half of the Moray Firth and is the most valuable fishery in the Moray Firth. The squid fishery is seasonally important in the Moray Firth and landings are predominantly recorded in inshore areas along the south coast.

There are relatively very low recorded landings values of pelagic species in the Moray Firth, although there is a seasonal mackerel fishery targeted by inshore vessels.

Analysis of fishing effort by vessel category (2000-2009) shows that the large majority of fishing effort within offshore rectangle 45E7 is undertaken by vessels greater than 15 m in length. Activity by the 10-15 m and under 10 m fleets increases inshore in the ICES rectangle 44E7.

As a result of the restrictions placed upon availability of data regarding foreign vessel activity in UK waters, consultation and liaison with fishing interests active in the region will be required to establish the full extent of foreign vessel activity in the area. However, preliminary assessment of obtained data sets (over-flight sightings, MMO/Marine Scotland) shows there to be very little recorded activity of foreign vessels within the Moray Firth.

Data Gaps

It is considered that sufficient data is available to make assessment of the potential effects upon fisheries. MORL will, however, undertake consultation with the fishing industry throughout this process.

Environmental Impacts Scoping

Based on available literature, the following are perceived to be the potential effects on commercial fisheries as a result of the proposed OfTI within the marine environment:

Effect Description	Potential site specific effect	Potential cumulative and/or in-combination Effect
Presence of seabed obstacles	✓	✓
Adverse effects on commercially exploited species	✓	✓
Safety issues for fishing vessels and associated fishing activities	✓	✓
Interference with fisheries activities	✓	✓
Restricted or temporary loss of access to fishing grounds	✓	✓

Site-specific Impact Assessment Methodology

For each of the potential effects described above a survey or study and method of impact assessment is described in the tables below.

Potential Effect(s)	Presence of seabed obstacles
Survey/Study Proposed to Assess Effect	To determine the potential for effects to gear safety arising from the installation of the cable(s) and associated with the cable itself if not buried in its entire length (including rock placement), the following survey will be undertaken: Side-scan swathe bathymetry (see section 0)
Method of Impact Assessment	The baseline character of the seabed features will be determined during the EIA stage to understand whether there are any current hazards to fishing gear safety. It is intended that this baseline will be compared to post-construction surveys to identify any hazards to gear safety associated with the construction of the proposed OfTI structure.

Potential Effect(s)	Adverse effects on commercially exploited species Interference with fishing activities Restricted or temporary loss of access to fishing ground
Survey/Study Proposed to Assess Effect	To determine the potential for effects as listed above, the following studies will be undertaken: Description of fisheries in the area Assessment of landings data Assessment of effort data
Method of Impact Assessment	In the case of each effect, the assessment will take account of: <ul style="list-style-type: none"> - the spatial extent of effect - the duration of effect - the scale of effect - recoverability of the receptor - importance of the receptor

Potential Effect(s)	Safety issues for fishing vessels and associated fishing activities
Survey/Study Proposed to Assess Effect	To determine the potential for effects to navigational safety, the following study will be undertaken: Navigational risk assessment
Method of Impact Assessment	A navigational risk assessment will assess the risk associated with ship to ship collision, vessel grounding, collision with wind turbine array infrastructure and the potential effect on communication systems.

Site specific survey methodology

BEST PRACTICE GUIDANCE

The following references provide best practice guidance for use in assessing effects upon commercial fisheries:

- BWEA (2002). Best Practice Guidelines for Consultation for Offshore Renewable Developers
- CEFAS (2004). Guidance note for Environmental Impact Assessment in respect of FEPA and CPA requirements, version 2 – June 2004
- BERR (2008). Fishing Liaison with offshore wind and wet renewables group (FLOWW) recommendations for fisheries liaison
- OSPAR (2008). Guidance on Environmental Considerations for Offshore Wind Farm Development. Reference number: 2003-8

ADDITIONAL INFORMATION

To assist the assessment of potential effects of the proposed development upon commercial fisheries, consultation will be undertaken with the relevant national and local marine fisheries bodies and fishermen's associations and representatives.

OTHER SURVEYS TO BE USED TO IDENTIFY EFFECTS

- Vessel routing surveys are described in section 5.3.3

Cumulative and In-combination Impact Assessment & Survey Methodologies

In addition to the potential effects of the development on the existing commercial fisheries baseline, the cumulative and in-combination effects will be separately considered using the impact assessment methodology provided above.

Potential Mitigation Measures

Potential mitigation measures include cable burial where possible and consultation with the fishing industry on appropriate cable protection measures where burial is not possible and on measures to ensure the integrity of the offshore export cable and fishing activities post-installation.

5.3.3 Shipping and Navigation

Baseline Environment

This section presents an overview of the navigational features in the Moray Firth which may be affected by the proposed OfTI.

The main ports in the area are Inverness, Cromarty Firth, Peterhead and Invergordon for commercial shipping as well as the fishing ports of Fraserburgh, Banff/Macduff and Buckie. It is also noted that the fabrication yards located at Nigg and Invergordon are utilised for constructing offshore structures as well as for refitting offshore drilling rigs. Rigs are often laid up in the Cromarty Firth whilst undergoing refurbishment or awaiting contracts.

MERCHANT SHIPPING

Figure 5-16 illustrates the shipping movements in the area based on an Automatic Identification System (AIS) shipping survey performed during winter 2010/2011. (AIS typically covers ships above 300 gross tonnes). It should be noted that this survey was being carried out at OGS area, and therefore with AIS coverage reducing towards the coast, resulting in underestimated densities closer to the coast.

From a commercial vessel perspective, the Moray Firth is generally not a busy area. The main shipping routes in the area are either headed into the Moray Firth and Inverness (e.g. shuttle tankers to the Nigg terminal) or using routes off Rattray Head bound for Pentland Firth and the Northern Isles (e.g. Northlink ferries to both Shetland and Orkney from Aberdeen).

Other routes in the vicinity of the OfTI consist of fishing vessels and tankers passing parallel to the Buchan coastline to local fishing ports and Inverness/Cromarty Firth, with a further route identified as being associated with offshore vessels supporting the Beatrice and Jacky Oil Fields from Peterhead and Aberdeen.

It is also worth noting that large tankers anchor in the general area around the proposed offshore cable corridor whilst awaiting orders.

FISHING VESSELS

The main fishing activity recorded in the vicinity of the proposed OfTI based on fisheries surveillance data (sightings and satellite) is from demersal trawlers, potters and scallop dredgers with a smaller number of pelagic trawlers recorded in the area.

The vast majority of these are UK-registered and associated with nearby Scottish northeast fishing ports such as Banff/Macduff, Buckie, Fraserburgh and Peterhead.

RECREATIONAL VESSELS

There are a number of recreational vessel activities taking place in the Moray Firth. Marinas are located at various points along the coastline, with the nearest being at Peterhead, Whitehills, Findochty and Buckie.

© SeaZone Solutions Limited, 2005, [012009.001, 022011.009]. This product includes mapping data licensed from Ordnance Survey (Great Britain) with the permission of HMSO. © Crown Copyright, 2006. All rights reserved. Moray Offshore Renewables Ltd © 2014. This document is the property of contractors and sub-contractors and shall not be reproduced without prior written approval.

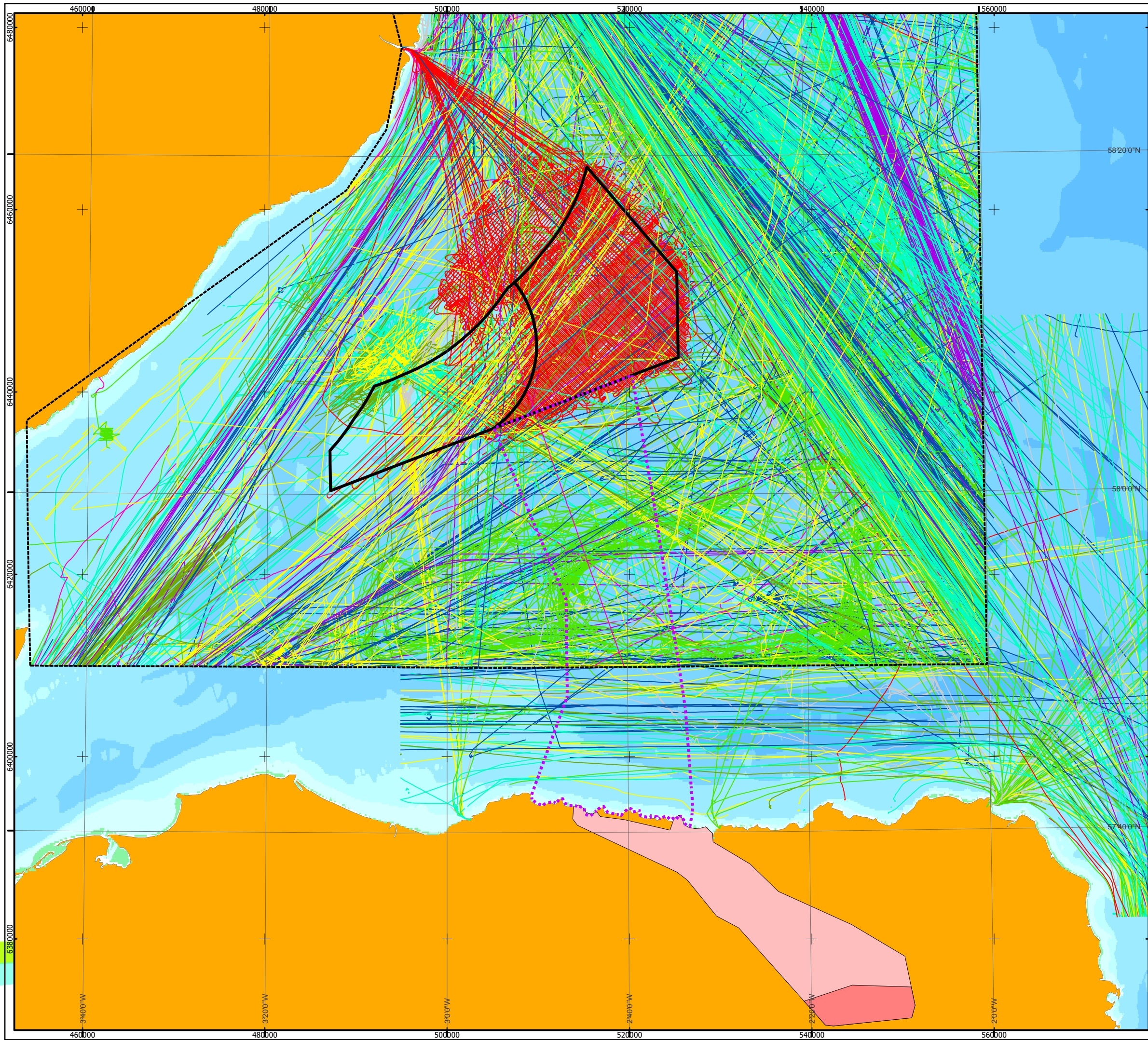

Moray Offshore Renewables Ltd

KEY

AIS Tracks (By Ship Type)

TYPE

- Fishing
- Military
- Dredger/Subsea
- Tug
- Passenger
- Cargo
- Tanker
- Recreation
- Other Ship
- Unspecified
- AIS Core of Survey
- Offshore Cable Corridor
- Onshore Substation Search Area
- Onshore Cable Corridor Search Area
- The Zone

Data: 38 Days Winter 2010-2011.

The apparent high shipping density recorded (RED) within MORL Eastern Development Area and BOWL Development Zone is associated with EIA Studies for the proposed wind farms (Birds & Marine Mammal boat-surveys).

Horizontal Scale: 1:400,000

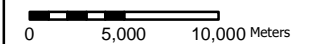

Geodetic Parameters: WGS84 UTM Zone 30N

Produced: RH
Reviewed: PM
Approved: SP

Date: 07/04/2014 Revision: B
REF: 8460001-PSO0010-MOR-MAP-044

Fig 5-16 Plot of AIS Tracks by Ship Type

Moray Offshore Renewables Ltd

© SeaZone Solutions Limited, 2005, [012009.001, 022011.009]. This product includes mapping data licensed from Ordnance Survey (Great Britain) with the permission of HMSO. © Crown Copyright, 2006. All rights reserved. Moray Offshore Renewables Ltd © 2014. This document is the property of contractors and sub-contractors and shall not be reproduced nor transmitted without prior written approval.

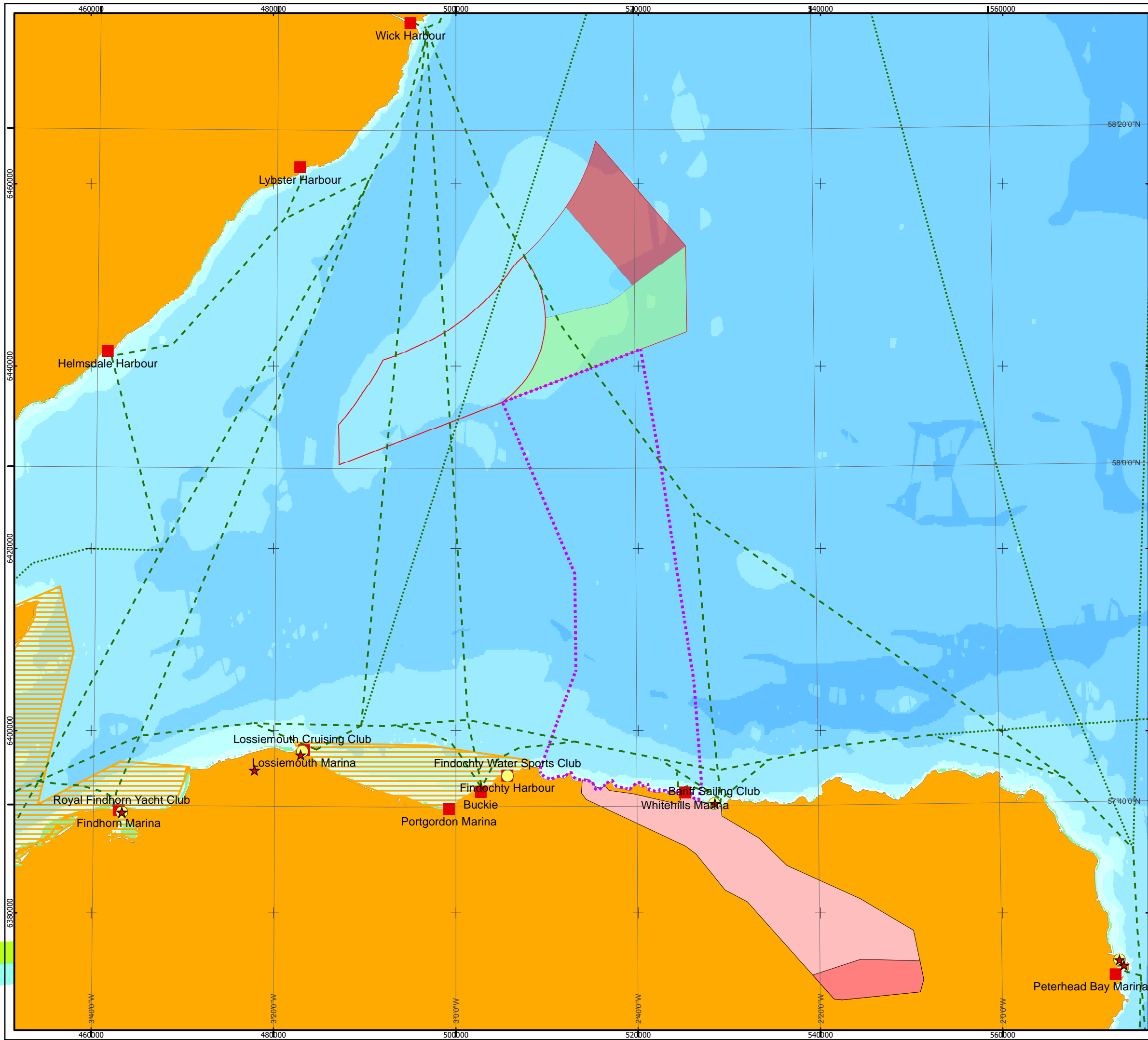

Moray Offshore Renewables Ltd

KEY

- ★ RYA Training centre
- RYA Club
- Marina
- Crusing Routes (Heavy use)
- - - Crusing Routes (Medium use)
- Crusing Routes (Light use)
- ▨ Sailing area
- ⋯ Offshore Cable Corridor
- Onshore Substation Search Area
- Onshore Cable Corridor Search Area
- The Zone

Horizontal Scale: 1:400,000

A3 Chart

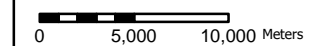

Geodetic Parameters: WGS84 UTM Zone 30N

Produced: RH
Reviewed: PM
Approved: SP

Date: 07/04/2014 Revision: B

REF: 8460001-PSO0010-MOR-MAP-045

Fig 5-17 Overview of Recreational Navigation Routes

Moray Offshore
Renewables Ltd

Two medium-use cruising routes (i.e. popular routes on which some recreational craft will be seen at most times during summer daylight hours) intersect the proposed offshore cable corridor (Figure 5-17).

There is also recreational traffic associated with the Caledonian Canal which has a northern entrance at Inverness.

Data Gaps

AIS data for the Moray Firth is available which predominantly covers commercial vessels over 300grt. Increasing numbers of fishing vessels are having AIS fitted and by 31st May 2014 all vessels whose overall length exceeds 15 m are required to have AIS installed.

Environmental Impacts Scoping

Based on experience from previous assessments of offshore wind farm developments, the following are perceived to be the main potential effects on navigation and shipping as a result of the proposed OfTI:

Effect Description	Potential site specific effect	Potential cumulative and/or in-combination effect
Increased collision risk (vessel to vessel and vessel to construction, vessel) during construction/installation phase	✓	✓
Anchors/fishing gear interacting with cable (emergency anchoring and dragged anchors)	✓	✓
Potential to reduce water depths and reduce underkeel clearance in event of cable protection being required above seabed which could result in vessel contacting seabed.	✓	✓
Potential effect on marine navigational equipment, i.e. magnetic compasses	✓	✓

Site-specific Impact Assessment Methodology

Where relevant, for the potential effects described above, a survey or study and method of impact assessment is described in the tables below.

Potential Effect(s)	Collision Risk Risk of Cable Interaction (anchors and fishing gear) Potential Effect on navigational equipment
Survey/Study Proposed to Assess Effect	To determine the potential for effects on shipping, a vessel traffic survey of the area will be performed in line with MCA's Marine Guidance Note 371: <i>Offshore Renewable Energy Installations (OREIs) - Guidance on UK Navigational Practice, Safety and Emergency Response Issues</i> This will be used as one of the inputs to the Marine Navigational Risk Assessment which will be carried out as per the recommended methodology outlined in the DTI (now DECC) publication <i>Guidance on the Assessment of the Impact of Offshore Wind Farms: Methodology for Assessing the Marine Navigational Safety Risks of Offshore Wind Farms</i> (the 'DTI Methodology').
Method of Impact Assessment	Survey data collected during the OGS EIA (MORL, 2012) will be used in the assessment of the effects listed above. The risk assessment/modelling will be carried out using a formal safety assessment process centred on a hazard workshop/consultation (as required) and resulting Hazard register.

Site specific survey methodology

Best practice guidance

The assessment will be undertaken in line with the following guidance:

- DTI (2005a). Methodology for Assessing the Marine Navigational Safety Risks of Offshore Wind Farms.
- Marine Guidance Note 371: Offshore Renewable Energy Installations (OREIs) - Guidance on UK Navigational Practice, Safety and Emergency Response Issues.

Details on survey methods used to collect data for the zone and the wider Moray Firth are provided in the MORL ES (MORL, 2012). These include vessel traffic surveys and a navigational risk assessment.

Cumulative and In-combination Impact Assessment & Survey Methodologies

Cumulative and in-combination issues associated with the offshore oil and gas activities as well as the adjacent BOWL offshore wind farm activities in the area will be evaluated.

The methodologies and potential survey requirements by which cumulative and in-combination effects for MORL's and BOWL's proposed wind farm developments were assessed were detailed in a consultation document undertaken on behalf of MORL and BOWL (ERM, 2011). The shipping and navigation assessment within the consultation report has been split into potential cumulative effects into hazard risks and operational risks for commercial, fishing vessels and recreational craft. Potential hazards resulting from the OfTI development include risk of collision, foundering and contact, as well as snagging in the case of fishing vessels and/or vessel anchors. Operational risks include increased fuel and time costs, loss of fishing/sailing area and potential loss of fishing equipment. This was further assessed for the MORL OGS in the MORL ES (MORL, 2012) and will also be assessed in the updated assessments in respect to the modified offshore cable corridor.

Potential Mitigation Methods

Potential mitigation measures for effects to navigation include:

- cable buried to depth where impairment is less likely;
- monitoring by radar, and/or AIS;
- guard vessels during construction using multi-channel Very High Frequency (VHF) and Digital Selective Calling (DSC); and
- publication of details through Notice to Mariners, inclusion within the cable details in FISHSAFE and chart updates via the UK Hydrographic Office and Kingfisher awareness charts.

The mitigation measures proposed for the OfTI area will be dependent upon the final design and the potential effects as determined by the Navigation Risk Assessment. Mitigation options will be discussed with the relevant stakeholders.

5.3.4 Ministry of Defence

Baseline Environment

Part of the proposed OfTI area lies within the large Air Force Department Area D712D, used for combat training and high energy manoeuvres at an altitude of 22,000 to 25,000 feet. The OSP locations (EDA) also partly lie within D809, which is used by the Royal Air Force (RAF) for a wide variety of air flying, gunnery and subsurface exercises at altitudes up to 55,000 feet.

The MoD use the Moray Firth as part of larger marine operations for surface and sub-surface naval activity and exercises.

Environmental Impacts Scoping

Based on available literature, the following are perceived to be the potential effects on the MoD and associated military activities as a result of construction/operation/decommissioning of the OfTI:

Effect Description	Potential site specific effect	Potential cumulative and/or in-combination Effect
Creation of obstacles to military operations	✓	✓

Site-specific Impact Assessment Methodology

Potential Effect(s)	Creation of obstacles to military operations
Survey/Study Proposed to Assess Effect	To determine the potential for effects to the creation of obstacles to military operations, the following study will be undertaken: Navigational risk assessment (see section 5.3.3.5)
Method of Impact Assessment	The assessments will be used to investigate the potential risks to military vessels which may pass through the proposed site (mainly during construction associated activities). Aviation issues have been covered by the aviation studies being undertaken for the OGS.

It is not predicted that the OfTI will interfere with air-based activities. Therefore the potential effect on military aviation activities is **scoped out**.

Cumulative and In-combination Impact Assessment & Survey Methodologies

Potential cumulative and in-combination effects on the MoD may arise from wider military activity in the area, resulting on increased restriction to vessel movement and military operations, mainly during construction.

It is currently anticipated that the navigation cumulative and in-combination impact assessments will cover Ministry of Defence issues.

Potential Mitigation Methods

Potential mitigation measures for effects on the MoD include specialist lighting and markings for the OSPs, the use of safety zones (if appropriate), guard vessels during construction and publication of details through Notice to Mariners and updates to the UK Hydrographic Office, micrositing of OSPs and burial of cables.

5.3.5 Marine Waste Disposal, Dumping and Dredging

Baseline Environment

There are, at present, no licensed areas for dredging aggregates within the Moray Firth. The nearest marine sites from which aggregates have been dredged are in the Firth of Forth (Marine Scotland, 2010). Regular deposition of dredged aggregates occurs within the Moray Firth with a total of 14,294 tonnes of aggregates deposited in the Moray Firth in 2005 and a further 31,375 tonnes deposited near the entrance to the Firth. The disposal sites are, however, all located near the south coast of the Firth such that there are no designated dredge sites or spoil dumps in the vicinity of OfTI. There is also a disposal site located near Wick on the north coast of the Firth (DECC, 2009b) but this also is not in close proximity to the OfTI.

Environmental Impacts Scoping

There are no disposal or dumping sites within the OfTI area therefore, **the potential for effects on disposal sites is scoped out**.

There are no aggregate areas within the Moray Firth, therefore, **the potential for effects on the aggregate industry are scoped out**.

5.3.6 Offshore Oil and Gas

Baseline Environment

Oil field development is the principal oil and gas activity currently within the Moray Firth.

The proposed OfTI will potentially lie within three blocks provisionally licensed for Oil and Gas exploration (see Figure 5-18). Two of these blocks are licensed to Suncor Energy Inc (Blocks 12/26b and 12/27, P1889). Suncor are the licence owner (49%), however, Norwegian Energy Company (NORECO) (22.5%) and Trap Oil Ltd (28%) own a share in the licence. The third block (12/21b, P1888) is owned by Sherritt International Corporation, with the licence owned by Sendero Petroleum Ltd (100%). These zones were awarded as part of the 26th and

27th Seaward Licensing Round. According to DECC the licences are anticipated to last until Q1 2038 (DECC, 2012).

Applications for blocks within the 27th Seaward Licensing Round for oil and gas were accepted as of 1st May 2012. These exploration licences were granted by DECC on the 17th December 2012 (DECC, 2012); as a consequence, no additional licence blocks were awarded within the proposed development area. On 24th January 2014, DECC invited applications for licences in the 28th licensing round. Applications will be accepted up until 25th April 2014. The progress of this will be analysed in relation to the proposed offshore cable corridor.

Data Gaps

Following the decision to grant the licence applications on the 26th seaward licensing round, there is sufficient information on oil assets within the Moray Firth. Additional information on future plans is anticipated to be obtained from consultation with relevant stakeholders. Consultation has commenced with the licence owners and is ongoing.

© SeaZone Solutions Limited, 2005, [012009.001, 022011.009]. This product includes mapping data licensed from Ordnance Survey (Great Britain) with the permission of HMSO. © Crown Copyright, 2006. All rights reserved. Moray Offshore Renewables Ltd © 2014. This document is the property of contractors and sub-contractors and shall not be reproduced nor transmitted without prior written approval.

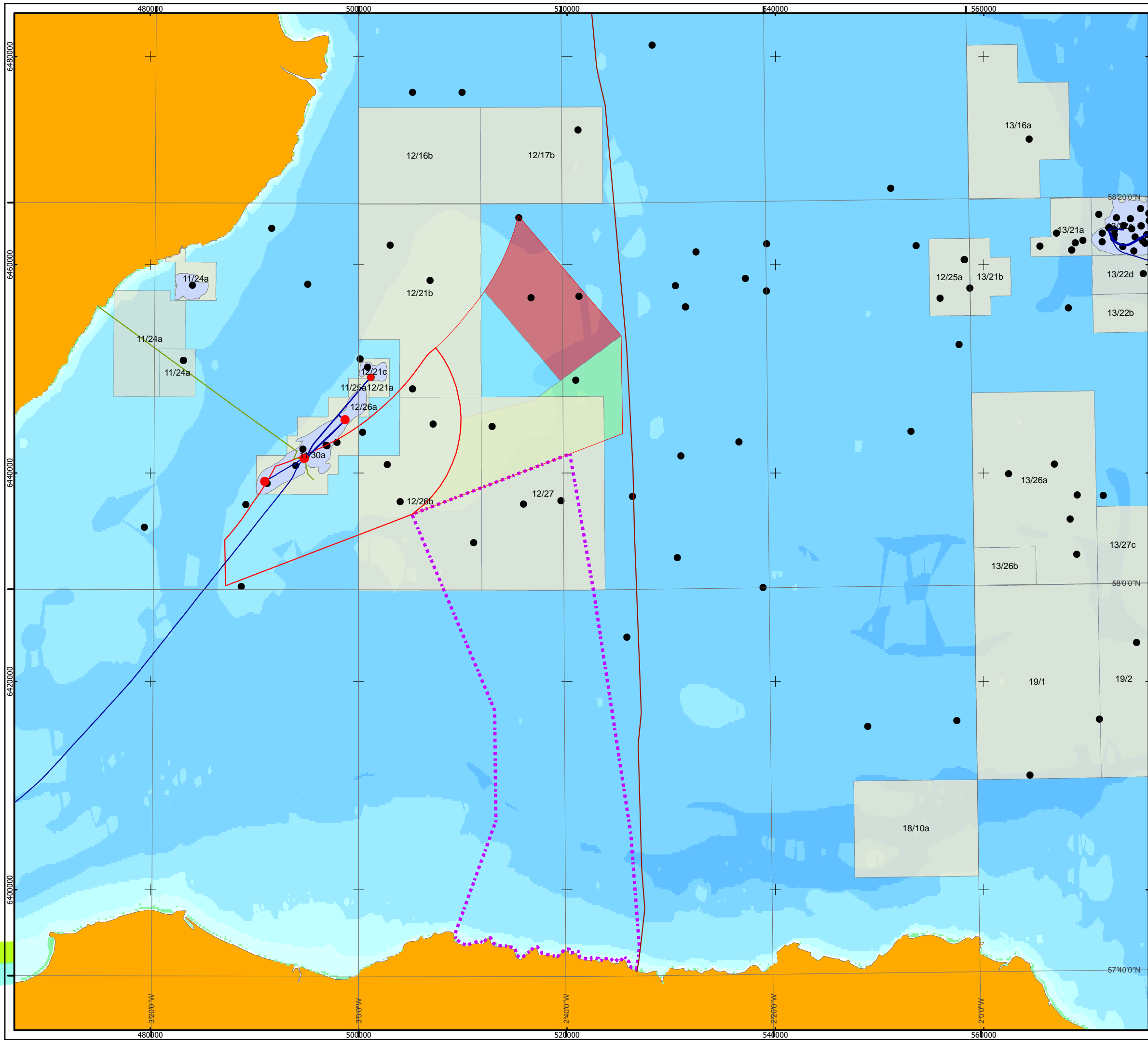

Moray Offshore Renewables Ltd

KEY

- Beatrice and Jacky Platforms
- Wells
- Subsea Cables
- Pipelines
- SHEFA-2 Cable
- Hydrocarbon Fields
- Licensed Blocks
- Sub-Area Blocks
- Offshore Cable Corridor
- The Zone

Horizontal Scale: 1:350,000

A3 Chart

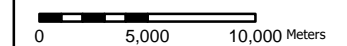

Geodetic Parameters: WGS84 UTM Zone 30N

Produced: RH
Reviewed: PM
Approved: SP

Date: 07/04/2014 Revision: B

REF: 8460001-PSO0010-MOR-MAP-037

Fig 5-18 Moray Firth Oil & Gas Licensing Blocks, Infrastructure, Subsea Cables and Pipelines

Moray Offshore Renewables Ltd

Environmental Impacts Scoping

There is no infrastructure within proposed areas of interest for the OfTI and access to the platforms is not routed through the OfTI development area. Therefore, the potential for effects on existing oil infrastructure is **scoped out**.

Cumulative and In-combination Impact Assessment & Survey Methodologies

The methodologies and potential survey requirements by which cumulative and in-combination effects will be assessed will be agreed with consultees, nevertheless it is likely they will follow the principles outlined within the MFOWDG Cumulative and In-Combination Impacts Assessment Discussion Document (ERM, 2011). In this report it is stated that cumulative effects related to the scope of Oil and Gas in the area are concerned with the cumulative effect on the activity of helicopters and vessels. The effects are largely considered under the Shipping and Navigation sections within the report.

5.3.7 Subsea Cables and Pipelines

Baseline Environment

There is one existing cable in proximity to the proposed OfTI. This is a telecommunications cable (SHEFA-2 Seg.9) which runs from the Orkney Islands to the Scottish coast at Inverboyndie (Kingfisher, 2008). The proposed offshore export cable could cross and potentially share landfall point with the SHEFA-2 cable.

Scottish Hydro Electric Transmission Limited (SHE-T) is obliged seeking to develop a transmission connection for the relief of onshore transmission capacity constraints largely driven by renewable energy projects on the Shetland Isles (e.g. Viking Wind Farm project) in the north of Scotland, Orkney and Shetland. SHE-T have proposed, and OFGEM are currently consulting on, a High Voltage Direct Current (HVDC) connection between the converted station at Upper Kergord, Shetland and Blackhillock, Moray, for which the subsea section could cross the proposed OfTI infrastructure.

BOWL has submitted an application to develop its export cable through the MORL WDA. BOWL has identified a survey corridor of 700 m that will consist of up to four cables. MORL have objected to this activity and this objection is pending resolution. BOWL's export cable landfall point is at Portgordon, to the west of MORL's proposed landfall options. The BOWL cable would not therefore need to be crossed.

Environmental Impacts Scoping

There are no pipelines within or in proximity to the proposed infrastructure. Therefore, the effects on pipelines are **scoped out**.

Based on available literature, the following are perceived to be the potential effects on cables as a result of the OfTI within the marine environment:

Effect Description	Potential site specific effect	Potential cumulative and/or in-combination Effect
Effects on safety (associated with export cable location and associated construction/operation works within works restriction zone)	✓	x

Site specific impact methodology

CONSULTATION

Information gathered through consultation will be the main technique used to guide the requirements for potential impact assessment studies and possible mitigation requirements. The main aim of the consultation will be to agree cable crossing and proximity agreements where necessary.

Potential Mitigation measures

The mitigation measures proposed for the final TI will be dependent upon the final design and the potential effects as determined by the EIA studies. Options of mitigation will be discussed with the relevant authorities.

5.3.8 Seascape, Landscape and Visual Receptors

Seascape is defined as “the coastal landscape and adjoining areas of open water, including views from land to sea, from sea to land and along the coastline” (DTI, 2005b). The effect upon seascape, landscape and visual resources is dependent upon a range of interacting factors, including, among others: the Zone of Theoretical Visibility (ZTV); the visual sensitivity of the area; the sensitivity of the landscape and seascape; meteorological conditions; the design and layout of the development; and, the location of the development. The TI includes both offshore and onshore elements and may give rise to seascape, landscape and visual effects. The completion of a seascape, landscape and visual assessment allows the significance of effects of the development on the landscape, seascape and visual resources to be assessed, with reference to established methodology and guidance.

The seascape, landscape and visual impact assessment (SLVIA) will assess the potential effects of the TI, consisting of up to two OSPs, up to four offshore export cables (below seabed surface), the cable landfall point (buried), up to four onshore export cables (buried) and onshore substations on seascape, landscape and visual receptors in a defined study area.

Baseline Environment

The TI consists of both offshore and onshore elements (substations and export cables), therefore the baseline environment consists of seascape, landscape and visual receptors. Seascape receptors are relevant for the OfTI; landscape receptors for the onshore elements. Visual receptors are relevant for both offshore and onshore elements.

STUDY AREA

The extent of the TI is illustrated in Figures 2-2 and 2-3. This will determine the study area for the SLVIA, which will include coastal areas of Caithness between Duncansby Head and Helmsdale; coastal areas of Moray between Lossiemouth and Cullen; and coastal areas of Aberdeenshire between Portsoy and the southern side of Peterhead. The study area will cover locations which may have visibility of both OfTI and OnTI. The OnTI (cable landfall, onshore export cables and onshore substations) will only be assessed for the Moray and Aberdeenshire sections of the study area, as the OnTI will not be visible from the Caithness coast.

SEASCAPE CHARACTER

A strategic seascape assessment for offshore wind has been completed for Scotland, which is based upon regional seascape units (Scott *et al.*, 2005). The assessment investigated the potential effect on seascape as capacity for development, which is derived from an assessment of the visibility of wind farms and the sensitivity and value of the seascapes. The study provides the basis for a seascape classification for Scotland at the national level. The regional seascape units of relevance to the proposed wind farm are:

- Area 5: North Aberdeenshire/Morayshire Coast;
- Area 6: Moray Firth; and
- Area 7: East Caithness & Sutherland

The seascape types that are found within these seascape units/areas are:

- Type 1: Remote High Cliffs;
- Type 2: Rocky coastline / open sea views;
- Type 3: Depression coastline / open views;
- Type 4: Outer firths;
- Subtype 4a: Smaller & less developed outer firths;
- Type 5: Developed inner firths;
- Type 6: Narrow coastal shelf.
- Type 11: Less developed inner firths.

The Scottish seascape study (Scott *et al.*, 2005) determined a strategic scale of national Seascape Units and Seascape Character Types. It suggests that a regional scale seascape character assessment is an appropriate level of detail for offshore wind development. The definition of these regional scale Seascape character units and their sensitivity to the proposals is an essential part of the assessment process and it is proposed that this will utilise the same methodology and units as those defined, and subsequently approved, in the MORL ES (2012). The methodology for undertaking this baseline seascape assessment will be based on published guidance, particularly the GSA, 2005 DTI Seascape Impact report and the Offshore Renewables – guidance on assessing the effect on coastal landscape and seascape by SNH (2012). Seascape character units/types have been defined along the Caithness and Moray coasts within the MORL ES (2012), and these will form the relevant baseline for all offshore components of the TI.

LANDSCAPE CHARACTER

The OnTI elements of the TI are located within Aberdeenshire; with the onshore substation search area located near to New Deer (Figure 2-4). This is discussed in more detail in the section below.

LANDFALL AND UNDERGROUND CABLE ROUTE

There are currently two alternative landfall points being considered, Sandend and Inverboyndie. Both are located in the Coast landscape character area; within the Cliffs of the North and South-East Coasts landscape unit, as identified in the Landscape Character Assessment of Banff and Buchan, Cobham Resource Consultants 1997, SNH Review No 37 and in Aberdeenshire Council's own 'Landscape Character Advice for Small Scale Development (LCASSD) 2012. This landscape unit is dominated by 'cliff-edged headlands, frequently fissured and bitten into by narrow inlets and, more rarely, hugging sheltered sandy bays such as those at Cruden and Sandend'; although the overall impression is of an open, exposed, large-scale landscape, with wide expanses of sky and sea. This character area is considered to be of increased landscape sensitivity due to its inherent characteristics. This area is coincident with what was historically identified as an Area of Landscape Significance by Aberdeenshire Council. However, the Local Development Plan (LDP) 2012 does not designate such areas and instead uses a landscape character approach to guide development. Policy 12 of the LDP, Landscape Conservation sets out the following:

'Aberdeenshire Council will plan for and promote the improvement and protection of all landscapes in Aberdeenshire by recognising and using landscape character areas. All the landscapes of Aberdeenshire are valuable assets and vulnerable resources, which are facing various pressures of change. We will use the Landscape Character Area framework as a basis for our future planning and management policy. We will also take into consideration particular opportunities, sensitivities and vulnerabilities of different landscapes, and make sure that the implications of development on these are managed in an appropriate and sensitive way.'

The specific relevant guidelines for this landscape area suggest that 'Hedgerows and stone dykes should be maintained and reinstated'. The effect on such features will form part of the assessment.

The remainder of the onshore export cable corridor area of search spans the following landscape character areas (and landscape units) in Aberdeenshire: The Coastal Farmland (Western Coastal Farmland and Coastal Farmland East of Macduff), The River Valleys (Deveron and Upper Ythan Valleys) and The Agricultural Heartland (Agricultural Heartland). The LCASSD advises that 'An area of increased landscape sensitivity exists to the north and west of Turriff, ...due to the qualities of the River Deveron Valley, including; the deciduous trees; river side trees; beech hedging and views along the river. This area is coincident with what was historically identified as an Area of Landscape Significance'.

The potential effect of the OnTI developments on these landscape character areas and landscape units will be considered in the assessment.

The only relevant landscape-related planning designations found in the study area are Gardens and Designed Landscapes (GDL). The only GDL located within the onshore export cable corridor search area is Duff House, although Forglen and Hatton Castle are found less than 2 km to south-west of the area. The effect of a proposed development on a garden or designed landscape (GDL) is a material consideration in decisions on planning applications and change should be managed to ensure that the significant elements justifying designation are protected or enhanced.

VISUAL RESOURCE

There are a number of settlements within the onshore export cable search area, ranging from the coastal town of Banff to villages such as New Deer and Cuminstown to scattered rural properties. These settlements are linked by a network of roads, including the main routes of the A98, A97 and A947. No railways are present in the study area.

National Cycle Route 1 (which is also part of the North Sea Cycle Route) runs through the search area several times, passing from Maud to Turiff, then up to Banff and across to Portsoy. There are no officially recognised Long Distance Routes (walking routes) in the search area, although a small section of The Formartine and Buchan Way (one of Scotland's Great Trails) runs less than 500m away from the south east corner of the area. There are also several regional footpath routes used by walkers, as well as cyclists.

A number of tourist and other visitor attractions are found in the onshore export cable search area, including beaches, Duff House and grounds (GDL) and historic landscape features, including a number of castles.

The effect of the TI developments on all of these potential visual receptors will be assessed fully in the SLVIA.

ONSHORE SUBSTATION SEARCH AREA

LANDSCAPE CHARACTER

The proposed onshore substation search area is located within Aberdeenshire, to the south-west of New Deer. The search area for the substations lies within the Agricultural Heartland landscape character area as identified in Aberdeenshire Council's Strategic Guidance SG Landscape 1: Landscape character and described in the Landscape Character Assessment of Banff and Buchan, Cobham Resource Consultants 1997, SNH Review No 37. Within Aberdeenshire the Agricultural Heartland landscape is extensive and covers several different geographical areas. Agricultural plains are the prominent characteristic and they tend to be influenced by the interior landscapes rather than the coast. Some diversity is created by elevation, landform and the incidence of wooded estates. The specific area of Agricultural Heartlands where the search area lies typifies the characteristic agricultural heartland of what was previously called Banff and Buchan and is now part of Aberdeenshire Council Local Authority. The Banff and Buchan landscape assessment describes the area as follows:

The gently rolling landform allows open views of the surrounding landscape, and on clear days the movement of clouds overhead forms patterns of light and shade across the broad plains.

The frequent scattering of broad-leaved trees in shelterbelts along hill-ridges, around farms and, more occasionally, in small coniferous blocks, combine to enliven the landscape and prevent any feeling of bleakness

in this vast agricultural plain. Field boundaries vary, including fence-lines, beech and thorn hedges to the south and east, and the occasional stone walls and consumption dykes to the north near Strichen.

Farmsteads are frequent in this relatively well-settled landscape, as are small hamlets such as New Byth. Larger villages include Strichen, a fine example of a planned village, set in the sheltered North Ugie valley; New Deer, set on a ridge overlooking rolling farmland; and Cuminestown, the plan of which resembles the letter Z.' Scattered churches and community buildings provide features and gathering points within the landscape. These, as well as the larger settlements and the large numbers of farms and dwellings are connected by an extensive network of minor roads. Along with the geometrically laid out fields and angular plantings, these create a strong - patchwork type - pattern across the rolling landscape, which is emphasised by the variety of arable crops. The settled landscape is criss-crossed by pole mounted transmission lines and the pylon mounted transmission line (into which the TI will connect) is a prominent feature in some locations. Views within the Agricultural Heartland landscape are confined in places to local areas with the rolling landform providing containment as well as vantage points where more distant views become available.

The potential effect of the OnTI developments on this landscape character area will be considered in the assessment.

Apart from some small areas of ancient woodland, there are no relevant landscape-related planning designations within the substation search area. However, within 5 km, there are GDLs at Hatton Castle, Fyvie Castle and Haddo House.

VISUAL RESOURCE

There are a number of small settlements located within the substation search area, ranging from the village of New Deer, to small hamlets such as Millbrex and Burnside, as well as numerous scattered rural properties and farmsteads. These are linked by an extensive network of minor roads, in addition to the A948 and B9170.

A section of the National Cycle Route 1 (which is also part of the North Sea Cycle) runs less than 500 m to the east of the study area, running from Auchnagatt to Maud. This route also forms part of The Formartine and Buchan Way (one of Scotland's Great Trails). There are no tourist and other visitor attractions of significance within the substation search area; although within 5 km there are a number of historic landscape features, country parks and properties that constitute Gardens and Designed Landscapes.

The effect of the OnTI developments on all of these potential visual receptors will be assessed fully in the SLVIA.

Data gaps

A study to determine cumulative and in-combination viewpoints will be required. Site visits to viewpoints and the production of site specific ZTVs will also be required.

Environmental Impacts Scoping

Based on available literature and understanding of the study area, the following are perceived to be the potential effects on the seascape, landscape and visual environments as a result of the TI:

Effect Description	Potential site specific effect	Potential cumulative and/or in-combination effect
Change in seascape character	✓	✓
Change in landscape character	✓	✓
Change in visual resource	✓	✓

Site Specific Impact Methodology

For each of the potential effects described above, a survey or study and method of impact assessment is described in the tables below.

Potential Effect(s)	Change in seascape character during construction, operation and decommissioning of the OfTI developments: Direct and indirect effects on seascape character units; and Direct and indirect effects on designated seascapes.
Survey/Study Proposed to Assess Effect	To determine the potential for effects on landscape character, the following studies will be undertaken: Desk-based study using a ZTV; and Field work to confirm desk-based study, delineate and describe regional seascape units/areas.
Method of Impact Assessment	The SLVIA will be undertaken with due regard to best practice guidance set out in: Countryside Council for Wales: Guide to Best Practice in Seascape Assessment (2001); Landscape Institute and Institute of Environmental Management and Assessment Guidelines for Landscape and Visual Impact Assessment': Second Edition (2002); Department of Trade and Industry, Guidance on the Assessment of Impact of Offshore Wind Farms: Seascape and Visual Impact Report (November 2005); and SNH, Natural England: Seascape Character Assessment Guidance (2012).

Potential Effect(s)	Change in landscape character during construction, operation and decommissioning of the OnTI developments: Direct effects on landscape character types/units. Indirect effects on landscape character types/units. Direct and indirect effects on designated landscapes.
Survey/Study Proposed to Assess Effect	To determine the potential for effects on landscape character, the following studies will be undertaken: Desk-based study using a ZTV. Field work to confirm desk-based study, delineate and describe landscape character types/units.
Method of Impact Assessment	The LVIA will be undertaken with due regard to best practice guidance set out in: SNH, Countryside Agency: Landscape Character Assessment Guidance for England and Scotland (2002) Landscape Institute and Institute of Environmental Management and Assessment Guidelines for Landscape and Visual Impact Assessment': Second Edition (2002).

Potential Effect(s)	Change in visual resource during construction, operation and decommissioning of the TI developments: Direct and indirect effects on visual receptors, including: Views from residential areas; Views from transport routes, roads, railways, ferries; Views from designated landscapes; Views from publicly accessible historic environment features; Views from recreational routes, footpaths and cycleways; Views from other publicly accessible land; and Potential marine based views.
Survey/Study Proposed to Assess Effect	To determine the potential for effects on visual resources, the following studies will be undertaken: Desk-based study using a ZTV; Consultation with consultees to reach agreement on viewpoints; Assessment of meteorological data for visibility; Assessment of sea use/users; and Field survey to confirm desk-based study, describe and assess viewpoints.
Method of Impact Assessment	The SLVIA will be undertaken with due regard to best practice guidance set out in: Department of Trade and Industry, Guidance on the Assessment of Impact of Offshore Wind Farms: Seascape and Visual Impact Report (November 2005); Horner and MacLennan and Envision, Visual Representation of Windfarms: Good Practice Guidance (2006), for Scottish Natural Heritage, The Scottish Renewables Forum and the Scottish Society of Directors of Planning; and, Landscape Institute and Institute of Environmental Management and Assessment Guidelines for Landscape and Visual Impact Assessment': Second Edition (2002).

Site Specific Survey Methodology

The methodology for the SLVIA will accord with the Guidelines for the Assessment of Landscape and Visual Effects: Second Edition, 2002. This methodology has drawn on the considerable experience gained in this field of work.

A baseline desk study will be undertaken to review the existing seascape, landscape and visual resource of the study area and will form the basis against which to evaluate the sensitivity of the study area to the TI developments. The main elements of the baseline desk study will include a review of baseline information, seascape characterisation and baseline visual analysis.

The desk study will review existing mapping and written information sources, including admiralty charts, Ordnance Survey (OS) maps, aerial photography, existing landscape and seascape assessments, capacity studies, inventories of designed landscapes, development plans and Met Office weather data. Other surveys will also be relevant when defining the seascape, landscape and visual baseline, including activity surveys, tourist information, ferry route information, historic and cultural guides, cultural heritage, conservation interests and recreational route maps.

The maximum extent of the TI developments is shown in Figures 2-2 and 2-3. The study area for the EIA will be agreed in advance with the relevant consultees. Seascape characterisation and visual analysis will provide a robust baseline from which to assess the sensitivity and capacity of the study area to the TI. The seascape, landscape and visual assessment will be carried out through desk study, field survey and analysis.

A baseline seascape, landscape and visual characterisation will be undertaken to define the seascape units and landscape types of potential significance in the study area, based on published seascape and landscape character assessment methodologies. In tandem with this seascape and landscape characterisation, the visual resource of the study area will be defined and sensitive receptors identified, through analysis of activities, visibility and views in the study area, and with reference to published guidance on visual assessment. Representative viewpoints will be identified from which to predict and assess the effects of the TI developments.

Following the completion of the seascape characterisation and baseline visual analysis, the sensitivity of the seascape, landscape and visual resource to change of the nature proposed will be assessed and this will form the basis for the assessment. The sensitivity of the seascape and visual resource will be evaluated and defined in terms of the interactions between the landscape and views, the way it is perceived and valued, and the particular nature of the type of change associated with the TI. The determination of the sensitivity of the seascape and visual resource will be based on an assessment of key elements and characteristics, using defined criteria, to arrive at an overall sensitivity for each seascape/landscape unit and visual receptor/viewpoint.

The magnitude of change to both the identified seascape/landscape units and visual receptors (such as viewpoints, settlements, routes and visitor attractions) will be assessed in a transparent manner. The magnitude of change arising from the TI will be described based on the interpretation of a combination of factors, such as the distance from the infrastructure, the amount of the infrastructure that is visible, the proportion of view occupied, the position and relationship of the infrastructure to other focal points, the duration of effect - whether temporary or permanent, intermittent or continuous, frequent or infrequent, and the number and extent of resources affected.

The SLVIA will include the residual effects during construction, operation and decommissioning on landscape elements, seascape character and visual receptors. An assessment of the significance of effects will be carried out based on the combination of the sensitivity to change of a given receptor and the magnitude of change upon it resulting from the developments. The assessment will include assessment and reporting of effects on landscape fabric (physical effects), assessment of effects on landscape and seascape character and assessment of effects on visual resources.

When predicting the potential seascape, landscape and visual effects, the extent of potential visibility of the onshore substation will be shown using a Zone of Theoretical Visual influence (ZTV). A visibility assessment of

the onshore substation will be carried out using the ZTV to describe the general extent and pattern of visibility of the TI within the study area. The visibility assessment will also describe the extent of visibility from the main activities in the study area, such as recreational activities, settlements and the main road, rail and footpath network.

Viewpoint photography, wirelines and photomontages will be prepared and presented in accordance with current best practice techniques. Viewpoint locations specific to the onshore substation locations will be included in the assessment. The viewpoint locations will be defined upon confirmation of the location of the onshore substations. These viewpoints will then be proposed/ discussed with relevant stakeholders.

Viewpoints specific to the OfTI and the cable landfall will also be included in the assessment. The location of the landfall, the offshore cable corridor and offshore substations will be indicated, together with the offshore wind turbines, to illustrate the relationships between the potential locations of the cable laying vessels, OSPs and the offshore wind turbines.

Photographs will show the existing view from these locations and a computer visualisation/wireline view of the development proposals will be produced for each viewpoint. Rendered photomontages of the onshore substations will also be produced. Plan graphics will illustrate the TI development proposals in relation to the seascape, landscape and visual receptors on OS mapping or aerial photography.

Summary of Methodology

IDENTIFICATION OF POTENTIAL EFFECTS AND PROPOSED ASSESSMENT METHODOLOGY

Using industry guidance contained within the relevant documents referred to below, the SLVIA will undertake the following:

- A scoping exercise and consultation with statutory and non-statutory consultees to establish valued regional and local landscape and seascape resources and viewpoints;
- Baseline studies of existing landscape, seascape and visual environment incorporating national level conclusions;
- Assess the sensitivity of those resources and receptors to the proposals;
- Provide advice on any mitigation that may be possible, e.g. layout or screening and incorporate agreed mitigation into the scheme description;
- Propose and agree monitoring;
- Identify the potential effects of the proposal on the landscape, seascape and visual environment during the construction, operation and decommissioning phases of the project and assess the significance of these effects.
- A cumulative assessment on the combined effects of the proposed development in combination with any other major developments that lie within the agreed study area. A list of such developments would be agreed with the relevant authorities; and
- Present the finding in the ES.

Cumulative and In Combination Impact Assessment

Cumulative seascape, landscape and visual impact assessment (CSLVIA) will be undertaken to take account of the TI works and the consented MORL turbines as well as other agreed developments. In particular, this will include the consented BOWL wind farm, the Beatrice demonstrator project and other operational, consented and application stage onshore wind farms with which the TI developments may combine to create additional cumulative effects. The cumulative effect of the TI developments will also be assessed in combination with other types of relevant development, including, for example, existing substations. The methodologies and potential survey requirements by which cumulative and in-combination effects will be assessed will be agreed with consultees as part of ongoing consultation with stakeholders.

Potential Mitigation Methods

Alongside the assessment, options for mitigation of the identified potential effects which are predicted to arise from the TI development will be considered, and practical measures agreed to avoid, reduce or off-set these effects. The SLVIA will identify measures for avoiding or reducing the level of significance of potential effects. These measures will potentially include:

- measures embedded into the design;
- measures additional to these which would further reduce long term seascape, landscape and visual effects (such as recommendations for potential landscape or habitat enhancement measures); and
- measures which would reduce landscape and visual effects due to construction, including details of restoration measures.

Potential embedded mitigation measures for effects on seascape, landscape and visual effects include the site selection for TI development, e.g. locating at distance from the coast and the realisation of design objectives for the development, achieved through alterations to layout, design and siting of TI facilities. Landscape and visual input into the site design is likely to be important for the onshore substations, where there may be opportunities to consider landscape mitigation measures to improve the integration of the development with the landscape and create beneficial effects in the long term, such as new planting, habitat creation etc. The TI development proposals will be modelled, represented and interrogated using 3D visualisation software, to assist with the siting, layout and design of the development proposals.

The mitigation measures proposed for the TI development area will be dependent upon the final design of the site and the potential effects as determined by the EIA studies. Mitigation options will be discussed with the relevant authorities.

5.3.9 Archaeology and Cultural Heritage

The archaeological and cultural heritage features that will require consideration for the TI will be located within the marine environment (around the OSPs and offshore cable corridor) and terrestrial environment (along the onshore cable corridor search area and around the onshore substation search area).

It is acknowledged that the seas around Britain contain many archaeological sites and remains. Such sites reflect the changing nature of both the coastline around Britain and the activities of the country throughout previous centuries, and broadly include:

- Submerged prehistoric landscapes formed when parts of the UK seas were still dry land;
- Remains and sites, including but not limited to shipwrecks, evidence of Britain's early history; and
- More recent sites, reflecting Britain's role as a major naval, mercantile, industrial and imperial power.

Cultural heritage and archaeological assets within the marine environment are located both on and below the seabed. Cultural heritage and archaeological remains that are afforded protection include wrecks and wreckage of historical, archaeological or artistic importance designated as protected or dangerous under the Protection of Wrecks Act (1973) (soon to be replaced in Scottish waters by Marine Protected Areas (MPAs) under the Marine (Scotland) Act 2010); military remains designated as 'protected places' or 'controlled sites' under the Protection of Military Remains Act (1986); and Scheduled Monuments designated under the Ancient Monuments and Archaeology Act (1979) (through the Historic Environment (Amendment Scotland) Bill in Scotland). It is an offence to cause damage to protected archaeological remains and in some cases where a restricted zone exists around the remains, a licence is required before any intrusive works can be undertaken. Restricted zones can vary in size depending on the extent of any associated remains and the degree of sensitivity of a site. Obstructions and foul ground areas also have the potential to represent cultural heritage assets but are not classified as such until the character of such anomalies have been confirmed. The Merchant

Shipping Act 1995 also requires that any material classified as 'wreck' recovered from the seabed during the course of a development is reported as a legal requirement to the Receiver of Wreck.

In addition to cultural heritage assets that are afforded protection, the seas around Scotland also contain a large number of assets that are currently unprotected or that are yet to be discovered.

The archaeological and cultural heritage assets requiring assessment with respect to the OnTI are located within the vicinity of the onshore cable route corridor search area and the onshore substation search area.

The OnTI Archaeology EIA will assess the potential for effects on buried archaeology, cultural heritage sites and historic environment features in the wider surroundings. Archaeological and cultural heritage assets will be identified through a desk-based assessment, including a review of historical maps and aerial photographs, checking databases of known sites, consultation with Historic Scotland and Aberdeenshire Council, and a targeted site walkover.

The main legislation, guidance and policy that will require consideration for the EIA are the Ancient Monuments and Archaeological Areas Act 1979, Planning (Listed Buildings and Conservation Areas) (Scotland) Act 1997, the Historic Environment (Amendment) (Scotland) Act 2011, the Town and Country Planning (General Development Procedure) (Scotland) Order 1992, Scottish Planning Policy (SPP) February 2010, PAN2/2011 Planning and Archaeology and Managing Change in the Historic Environment: Setting (Historic Scotland, October 2010);

There is a wide range of designations relating to heritage assets. These include:

- **World Heritage Sites** – defined by the United Nations Educational, Scientific and Cultural Organisation (UNESCO) as places of 'outstanding universal value', selected for their important cultural or natural features.
- **Scheduled Ancient Monuments (SAM)** – monuments of national importance that Scottish Ministers have given legal protection under the Ancient Monuments and Archaeological Areas Act 1979.
- **Listed buildings (LB)** – structures of special architectural or historic interest assigned by Historic Scotland to one of three categories (A, B or C) according to their relative importance.
- **Conservation Areas** – areas of special architectural or historic interest which character or appearance are desirable to preserve or enhance.
- **Properties in Care** – properties which are managed by Historic Scotland on behalf of others, including Scottish Ministers.
- **Gardens and Designated Landscapes (GDL)** – gardens and landscapes considered by Historic Scotland as nationally as valuable assets at national, regional and local level.
- **Registered Battlefields** – battlefields that are considered to be of national importance satisfying the criteria provided in the *Scottish Historic Environment Policy*.

Most heritage assets are, however, undesignated and many are currently unrecorded.

Baseline Environment

OFFSHORE ENVIRONMENT

A total of 375 marine cultural heritage assets have been identified along the Moray Firth coastline from previous surveys commissioned by Historic Scotland; most of which represent intertidal sites (Talisman, 2005). In addition to cultural heritage assets within the Moray Firth, there are many recorded maritime losses in the area. The strategic importance of the Moray Firth area in the recent past; the concentration of much of the North Sea fishing fleet in coastal ports along the north east coast of Scotland; the importance of maritime trade routes in the area; and the treacherous nature of near shore waters is likely to account for these losses.

There are sixteen charted wrecks within the OfTI area (Figure 5-19). While these assets are not currently afforded statutory protection it is noted that sites found to exhibit national or international significance can be classified within the lifetime of a project. There are no 'dangerous wrecks' within the search area, but there is

one uncategorised wreck (Ebenezer) in the shallow waters near the landfall point at Inverboyndie and a further three within the search area.

Fleming (2004) stated that it was difficult to predict the potential for pre-historic remains within the central North Sea, but there was a low probability of finding *in situ* remains in the offshore environment because of the strong currents, exposure to North Atlantic storms, thin sediment cover and large areas of exposed bedrock in this area. The probability of finding remains within the region was greater in more sheltered coastal areas. However, there has not been a detailed study of the proposed development area.

© Seazone Solutions Limited, 2005, [012009.001, 022011.009]. This product includes mapping data licensed from Ordnance Survey (Great Britain) with the permission of HMSO. © Crown Copyright, 2006. All rights reserved. Moray Offshore Renewables Ltd © 2014. This document is the property of contractors and sub-contractors and shall not be reproduced nor transmitted without prior written approval.

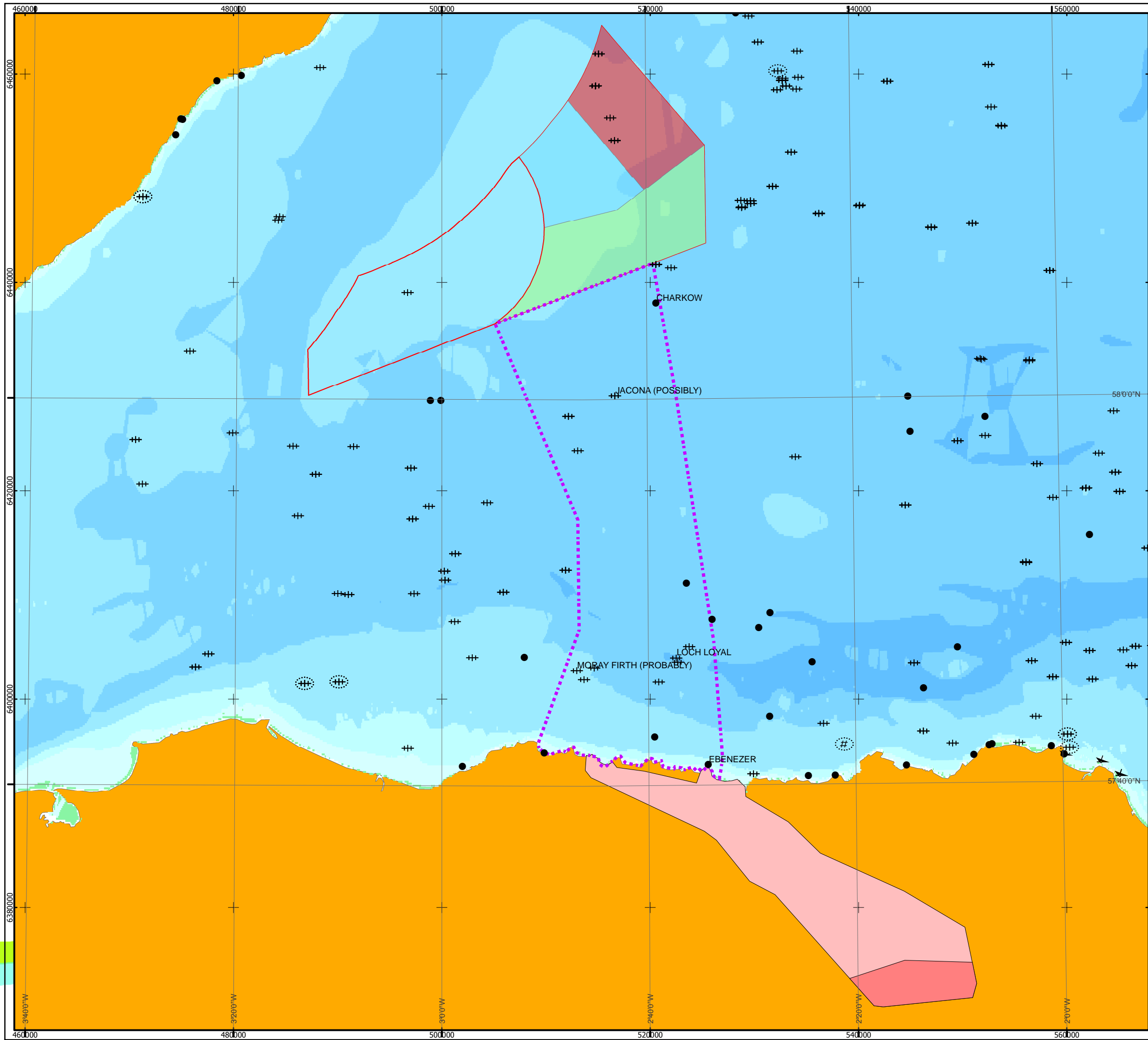

Moray Offshore Renewables Ltd

KEY

- dangerous wreck
- non-dangerous wreck
- wreck showing hull or superstructure
- distributed remains of wreck
- uncategoryed wreck
- Offshore Cable Corridor
- Onshore Substation Search Area
- Onshore Cable Corridor Search Area
- The Zone

Horizontal Scale: 1:350,000

A3 Chart

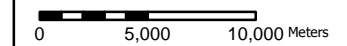

Geodetic Parameters: WGS84 UTM Zone 30N

Produced: RH
 Reviewed: PM
 Approved: SP

Date: 07/04/2014 Revision: B

REF: 8460001-PSO0010-MOR-MAP-046

Fig 5-19 Recorded Wrecks

**Moray Offshore
 Renewables Ltd**

ONSHORE ENVIRONMENT

There are a number of designated assets within the onshore cable corridor search area (Figure 5-20 and Figure 5-21) as follows:

There are 14 Scheduled Monuments (SMs) within the onshore cable corridor search area. These are shown in the table below

Scheduled Monuments within the cable route corridor search area

Index number	Name
2458	Castle of King Edward
2927	Banff Castle
3008	Duff House, mausoleum 300m SW of the Orchard
4271	Sandend Windmill, Fordyce
5617	King Edward Old Parish Church, church 220m SW of Den Bridge
5638	Eden Castle
5668	Boyndie Old Kirk, church 200m NW of Boyndie Bridge
5779	Hills of Boyndie, barrows & enclosures 700m SW of Mill of Boyndie
5951	Fedderate Castle
6645	Banff, St Mary's parish church and burial ground
9392	North Mains of Auchmaliddie, stone circle 500m SW of
11027	Law of Balgreen, cairn
11034	Hill of Alvah, cairns 1350m WSW of Mill of Alvah
11035	Stirling Cairn, cairn 750m SW of Mill of Alvah

There are 29 Category A, 226 Category B and 262 Category C listed buildings within the onshore cable corridor search area (Figure 5-22).

Of the listed buildings, 59 are clustered within or immediately adjacent to the conservation area at Sandend. Of the listed buildings in the Sandend conservation area, 18 are listed at Category B, while a further 41 are listed at Category C.

A further ten listed buildings are clustered within the conservation area at Portsoy. Of the listed buildings in the Portsoy conservation area, nine are listed at Category B, while one is listed at Category C. In addition, some 71 listed buildings are clustered within the conservation area at Whitehills. Of these, 56 are listed at Category B, while 15 are listed at Category C.

A further 265 listed buildings are clustered within the conservation area at Banff. Of the listed buildings in the Banff conservation area, 20 are listed at Category A 121 are listed at Category B, while 124 are listed at Category C.

There is one inventoried garden and designed landscape within the onshore cable corridor search area (Figure 5-22). This is Duff House, located immediately south of Banff. Duff House itself is listed at Category A (HB number 21985) and is located within the inventoried garden and designed landscape. This listed building, along with several others and a large part of the northern end of the inventoried garden and designed landscape also lies within the Banff conservation area.

There are four conservation areas within the onshore cable corridor search area. These are Sandend, located on the west side of Sandend Bay, at the extreme northwest of the cable route corridor search area, Portsoy, located on the coast some 3km east of Sandend, Whitehills, located on the coast some 6km east of Portsoy and Banff, located on the coast at Banff approximately 3km southeast of Whitehills and incorporating part of the inventoried garden and designed landscape at Duff House.

There are no World Heritage Sites or registered battlefields within the onshore cable corridor search area

There are seven designated assets within the substation search area. Three are listed at Category B and four at Category C. Of the listed buildings within this part of the search area, one Category B and three Category C listed buildings are located within the built development of New Deer.

An initial assessment of undesignated assets within the onshore cable corridor search area has been undertaken in order to provide a broad characterisation of the resource. This has involved examining a sample of recorded undesignated assets from the centre of the proposed onshore cable corridor search area. This has indicated that there are over 250 recorded sites within the proposed onshore route corridor search area. Assets range in date from the prehistoric, with a number of cropmarks representing barrows, as well as finds of flints and metalwork, through medieval settlement, ecclesiastical and probably agricultural remains, to military remains dating from the second world war. The landscape has been largely rural and agricultural since early times.

Contains Ordnance Survey data © Crown Copyright and database right [2014]. Moray Offshore Renewables Ltd © 2014. This document is the property of contractors and sub-contractors and shall not be reproduced nor transmitted without prior written approval.

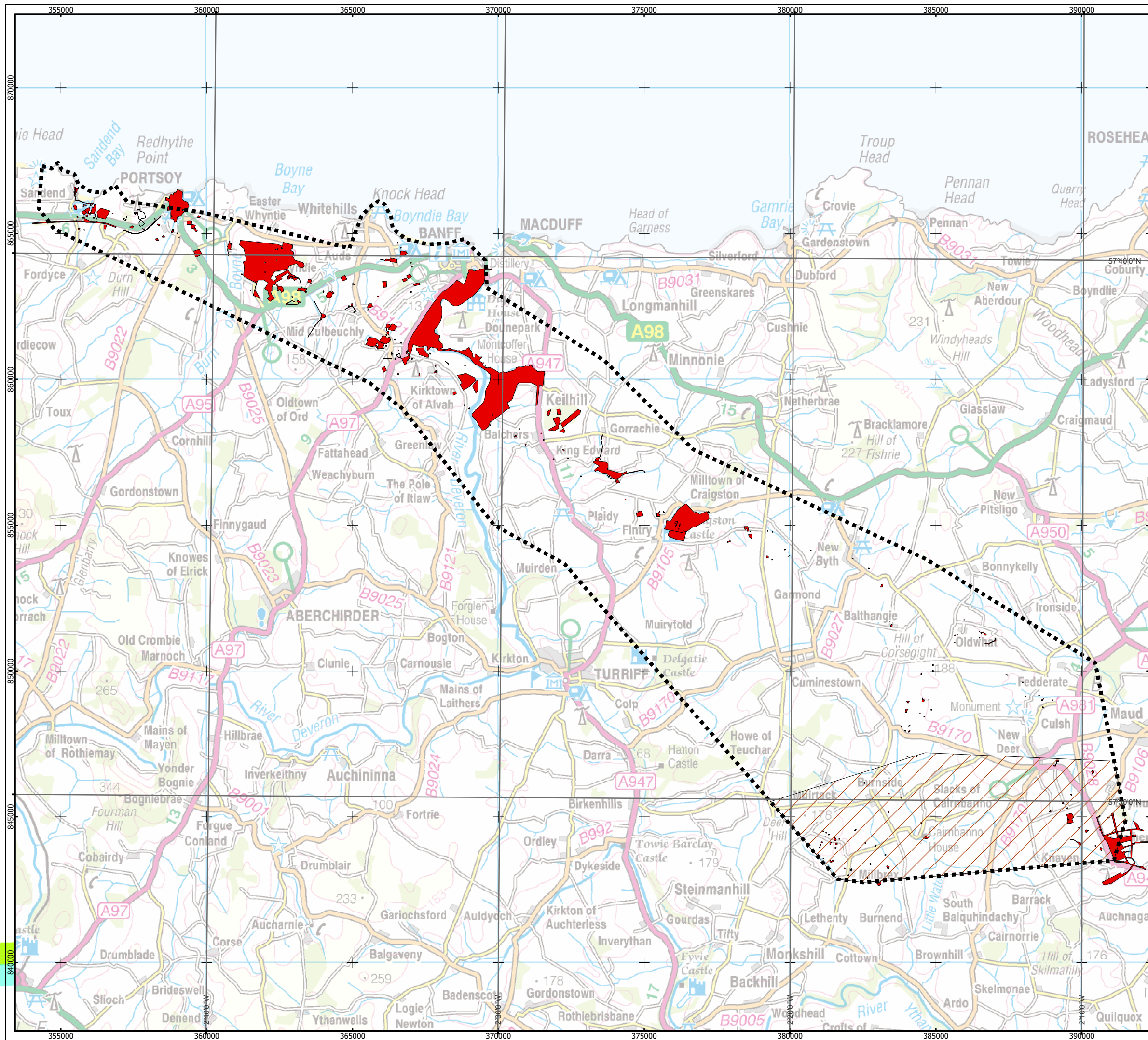

Moray Offshore Renewables Ltd

- KEY**
- Onshore Cable Corridor Search Area
 - Onshore Substation Search Area
 - Scheduled Monuments Records
- SMR data extract supplied by Aberdeenshire Council

Horizontal Scale: 1:125,000 A3 Chart

Geodetic Parameters: British National Grid	
Produced: KAG	
Reviewed: DS	
Approved: RH, SP	
Date: 02/04/2014	Revision: A
REF: 8460001-PSO0010-RPS-MAP-005	

Fig 5-20 Scheduled Monuments Records

Moray Offshore Renewables Ltd

Contains Ordnance Survey data © Crown Copyright and database right [2014].
 Historic Scotland data © Crown copyright. All rights reserved 2014.
 Moray Offshore Renewables Ltd © 2014. This document is the property of contractors and sub-contractors and shall not be reproduced nor transmitted without prior written approval.

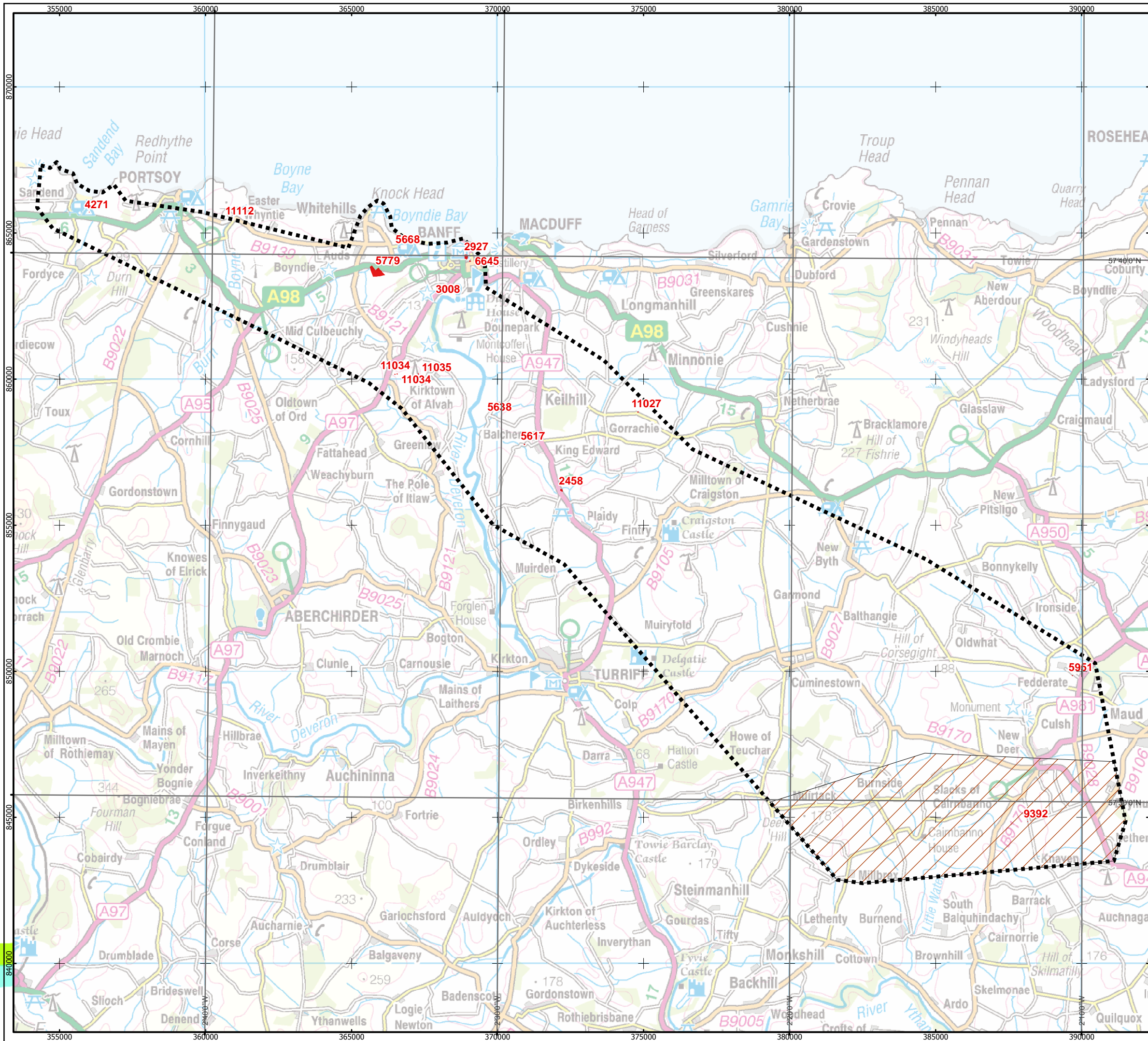

Moray Offshore Renewables Ltd

- KEY**
- Onshore Cable Corridor Search Area
 - Onshore Substation Search Area
 - Scheduled monuments

Horizontal Scale: 1:125,000 A3 Chart

Geodetic Parameters: British National Grid

Produced: KAG
 Reviewed: DS
 Approved: RH, SP

Date: 02/04/2014 Revision: A
 REF: 8460001-PSO0010-RPS-MAP-006

Fig 5-21 Scheduled Monuments

Moray Offshore
Renewables Ltd

Contains Ordnance Survey data © Crown Copyright and database right [2014].
 Historic Scotland data © Crown copyright. All rights reserved 2014.
 Moray Offshore Renewables Ltd © 2014. This document is the property of contractors and sub-contractors and shall not be reproduced nor transmitted without prior written approval.

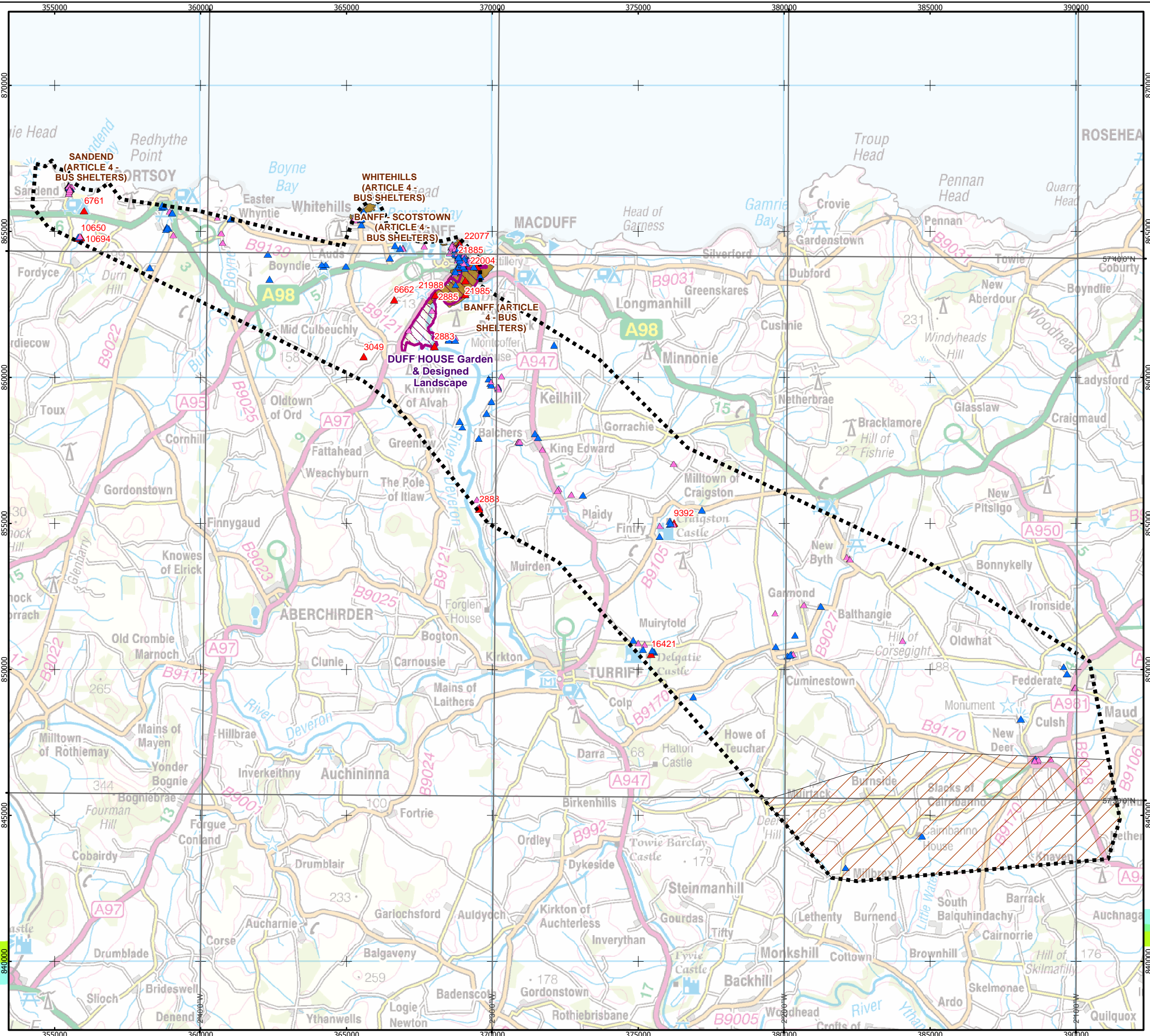

Moray Offshore Renewables Ltd

KEY

- Onshore Cable Corridor Search Area
- Onshore Substation Search Area

Listed Building (category)

- A
- B
- C(s)

Garden and Designed Landscapes

Conservation Area

Horizontal Scale: 1:125,000 A3 Chart
 0 2,500 5,000 Metres

Geodetic Parameters: British National Grid
 Produced: KAG
 Reviewed: DS
 Approved: RH, SP
 Date: 02/04/2014 Revision: A
 REF: 8460001-PSO0010-RPS-MAP-007

Fig 5-22 Listed Buildings, Gardens & Designated Landscapes, Conservation Areas

Data Gaps

There is a lack of site specific survey data and it is therefore anticipated that such data will be required for the impact assessment process. Knowledge of archaeological assets is inevitably partial, not all archaeological features will produce cropmarks as this is dependent on feature type, geology and agricultural regime. In addition, the baseline condition of archaeological assets within the onshore cable corridor search area is largely unknown.

Environmental Impacts Scoping

Based on available literature, the following are perceived to be the potential effects on the archaeology and cultural heritage as a result of TI within the marine environment:

OFFSHORE ENVIRONMENT

Effect Description	Potential site specific effect	Potential cumulative and/or in-combination effect
Contamination, damage or loss of archaeological remains in or on the seabed	✓	x
De-stabilisation of sites through changed sedimentary regimes	✓	x

Cable laying would seek to avoid any features of historical interest on the seabed and it is expected that any accidental disturbance of features will be afforded the appropriate response through established archaeological protocols and procedures for unexpected archaeological discoveries. During operation effects will be limited to potential indirect effects associated with altered patterns of seabed sediment erosion and accretion. Therefore, the potential for cumulative and in-combination effects on archaeology and cultural heritage are **scoped out**.

ONSHORE ENVIRONMENT

The following are perceived to be the likely potential effects on heritage assets as a result of the OnTI:

Effect Description	Potential site specific effect	Potential cumulative and/or in-combination effect
Damage or loss of features of onshore archaeological interest (permanent)	✓	x
Potential effects upon setting resulting from substation (permanent) and from construction of onshore export cable within the onshore cable corridor search area (temporary)	✓	x

There are a number of features of archaeological interest located within the landfall and onshore cable corridor search area. The activities associated with cable laying and construction of the onshore substations would seek to avoid any features of historical interest and it is expected that the chance of accidental disturbance of

features will be minimal. During operation, effects will be limited to potential indirect effects associated with maintenance of the export cable and potentially effects upon setting resulting from the presence of the substation in the landscape. None of these are likely to result in significant cumulative or in combination effects. Therefore, the potential for cumulative and in-combination effects on archaeology and cultural heritage are **scoped out**.

Potential Cumulative Effects

The simultaneous, successive and sequential cumulative effects of other developments within an agreed radius of the site which are either operational, under construction, consented or the subject of a full planning application will also be assessed. These will be identified through the LVIA, with the same cumulative developments assessed for consistency.

Site specific impact methodology

For each of the potential effects described above a survey or study and method of impact assessment is described in the tables below.

OFFSHORE ENVIRONMENT

Potential Effect(s)	Contamination, damage or loss of archaeological remains in or on the seabed
Survey/Study Proposed to Assess Effect	To determine the potential for effects on existing archaeological remains, the following studies will be undertaken: Assessment of archaeological potential and significance Geophysical and Geotechnical survey (see section 5.1.2)
Method of Impact Assessment	The assessment of archaeological potential and significance will be used to identify the potential archaeological remains within the area and their importance. The potential for effect upon these features will be assessed using a risk assessment of the direct effects of OSP/export cable location and construction methods.

Potential Effect(s)	Destabilisation of sites through changed sedimentary processes
Survey/Study Proposed to Assess Effect	To determine the potential for effects on existing archaeological remains, the following studies will be undertaken: Assessment of archaeological potential and significance Geophysical and Geotechnical survey (see section 5.1.2) Metocean studies (see section 5.1.2)
Method of Impact Assessment	The assessment of archaeological potential and significance will be used to identify the potential archaeological remains within the area and their importance. The potential for effect upon these features will be assessed in relation to the results of the potential for changes in the sediment transport regime (e.g. the potential to cause burial or exposure of features).

ONSHORE ENVIRONMENT

Potential effect(s)	Damage to or loss of heritage assets
Survey/Study Proposed to Assess Effect	To determine the potential for effects on heritage assets, the following studies will be undertaken: Desk study to map heritage assets within study area and wider context Field work to confirm desk-based study results and to identify additional features of archaeological importance
Method of Impact Assessment	The assessment of archaeological potential and significance will be used to identify the potential archaeological remains within the area and their relative importance. There are no 'standard criteria' for determining the significance of potential effects on heritage assets. The significance will therefore be determined using criteria developed from best practice techniques and expert knowledge in accordance to relevant legislation and guidance.

Potential Impact(s)	Potential effects upon setting resulting from substation (permanent) and from construction of onshore export cable within the onshore cable route corridor search area
Survey/Study Proposed to Assess Impact	To determine the potential for effects on heritage assets, the following studies will be undertaken: Desk study to map heritage assets within study area and wider context Fieldwork to establish baseline setting of assets in the cable route corridor search area and vicinity of the substation
Method of Impact Assessment	The assessment of setting will be used to identify the potential effect on the settings of heritage assets. There are no 'standard criteria' for determining the significance of potential effects on heritage assets. The significance will therefore be determined using criteria developed from best practice techniques and expert knowledge in accordance to relevant legislation and guidance.

Site specific survey methodology

BEST PRACTICE GUIDANCE

The scope will follow the non-statutory *Code of Practice for Seabed Developers* produced by the Joint Nautical Archaeology Policy Committee, and, where applicable, following the following guidance and legislation:

- Article 303 of the United Nations Convention on the Law of the Sea (UNCLOS)
- Article 2.ii. The European Convention on the Protection of the Archaeological Heritage (revised) (The Valetta Convention)
- Planning Advice Note 42 “Advice on the handling of archaeological matters within the planning process”
- Scottish Planning Policy 23 “Planning and the Historic Environment”
- Protection of Wrecks Act 1973
- The Ancient Monuments and Archaeological Areas Act 1979
- Protection of Military Remains Act 1986
- The Merchant Shipping Act 1995
- Historic Scotland Archaeological Procedure, Paper 4, 1996
- BMAPA & English Heritage (2003). Marine Aggregate Dredging and the Historic Environment: Guidance Note
- Wessex Archaeology Ltd (2007). Historic environment guidance for the offshore renewable energy
- The Crown Estate (2010). Offshore Renewables Protocol for Archaeological Discoveries; and
- The Crown Estate (2010). Round 3 Offshore Renewables Projects Model Clauses for Archaeological Written Schemes of Investigation.

For the OnTI, an extended desk based assessment of available information will be conducted to establish baseline conditions to enable assessment of both direct effects (physical) within the site, and indirect effects (visual effects on the settings of heritage assets etc) within the site and a study area around it. This will be carried out in accordance with current best practice guidance issued by the Institute for Archaeologists (IfA) and the Institute of Environmental Assessment and Management (IEMA) plus other relevant UK guidance on wind farm assessments.

The work will involve the gathering of baseline data relating to the known and potential archaeology and cultural heritage resources within a defined study area centred on the site of the onshore cable corridor search area and substations. Such resources will include nationally designated features such as SAMs, listed buildings, historic gardens and designed landscapes (HGDLs), locally designated features such as Conservation Areas, Areas of High Archaeological Potential (or similar), locally listed buildings etc, archaeological sites and find-spots recorded on the relevant Historic Environment Record (HER) and mapping evidence suggesting potential heritage assets. National guidance on archaeology and planning will be reviewed, along with relevant local and structure plan policies. Existing and available geological and geotechnical information will be examined, along with the data obtained by third parties looking at other aspects of the OnTI.

The primary information resource will be the Sites and Monuments Record, supplemented by relevant published documentary and cartographic material, as appropriate. Information on SAMs, listed buildings, HGDLs, etc, will be obtained from Historic Scotland. A review of relevant documentary and archival material held in libraries and archives would be undertaken. An iterative approach will be adopted during this process to determine the scope of the above consultations/searches. Existing and available geological and geotechnical information would be examined, along with the data obtained by third parties looking at other aspects of the OnTI.

Information sources may also include (amongst others):

- Online datasets, in particular Pastmap;
- National Monument Record of Scotland (NMRS); and
- Published and manuscript maps held by the National Library of Scotland.

The onshore study area will be as follows:

- For buried archaeological sites that are recorded on the Sites and Monuments Record but not otherwise designated, the study area is represented by the onshore cable corridor search area, as defined at the time of application. It is considered that information from the study area will inform the assessment of the sensitivity of the application site and the archaeological resources within it. It is also considered that there is no potential for direct effects on archaeology and cultural heritage features outside this study area.
- For designated historic environment resources of regional and local significance the study area is a buffer zone of 2 km radius around the onshore cable corridor search area, as defined at the time of application, and 3km around the substation locations. It is not considered that the potential for likely significant environmental effects on a cultural heritage resource of regional or local importance exists beyond a maximum of 5 km. Only those receptors that fall within the Zone of Theoretical Visibility (ZTV) will be identified and described.
- For designated archaeology and cultural heritage resources of international and national significance the study area is a buffer zone of 5 km radius around the onshore corridor search area and up to 10 km around the substations. Subject to the professional judgement of the cultural heritage consultant, a precautionary approach will be employed where more distant cultural heritage features of international and national significance are included in the initial stages of assessment, these only being discounted after a detailed assessment of their setting has been made. The study area is demonstrably robust to ensure that any likely significant environmental effects can be identified.

Data for various classes of monuments and designated features will be collected at appropriate ranges from the proposed wind farm development area. Consideration will be given to any Historic Land Use Assessment that exists for the site, in assessing effects upon the setting and character of the historic landscape.

Consultations with Historic Scotland and the Archaeology Service at Aberdeenshire Council will be undertaken as appropriate.

Supplementary data will be gathered through a reconnaissance field survey of the proposed site in order to provide information on the archaeological potential of the area. This fieldwork will be conducted to:

- Assess and validate data collected as part of the Desktop Assessment;
- Identify the extent and condition of any visible archaeological monuments, including any not previously recorded;
- Assess the topography and geomorphology of the proposed development area; and
- Inform an assessment of the site context as part of the wider historic landscape.

In order to inform the assessment of indirect effects on the setting of archaeology and cultural heritage features, key receptors outside the proposed OnTI development area will be visited, as appropriate and subject to access constraints. Such receptors may include SAMs, Listed Buildings and other designated features, such as HGDs. Features visited will include those identified by the desktop studies and those specifically identified via the consultation process.

The assessment will examine any potential direct effects (physical disturbance) and indirect effects (visual effect on archaeology and cultural heritage features and their settings) of the TI during the construction, operation and decommissioning stages. Reference will be made to visual resources and effects identified in the LVIA. Potential significant effects and mitigation measures will be detailed in the ES, and an assessment of residual effects presented.

Summary of methodology

ARCHAEOLOGICAL POTENTIAL AND SIGNIFICANCE

The offshore and onshore assessments would include collation of existing documentary evidence from a variety of sources in order to predict the likely character and extent of archaeological remains in the vicinity of the TI.

The desk-study would be supplemented by assessments of field data collected (offshore: geophysical survey, benthic and geotechnical campaigns; onshore: site visits). For the offshore assessment for instance, review of swathe bathymetry, side-scan sonar and sub-bottom profiling can be used to identify features of cultural heritage potential, such as wreck remains and associated debris and submerged features of palaeoenvironmental and archaeological interest. The analysis of grab also allows an assessment of the potential for submerged landscapes through sedimentary facies and associated human activity.

It should be noted that if any offshore wreck material is recovered, the developer will inform the Receiver of Wreck under Section 236 of The Merchant Shipping Act 1995, and await further instruction.

OTHER SURVEYS/STUDIES TO BE USED TO IDENTIFY EFFECTS

Geophysical, geotechnical and metocean surveys are described in section 5.1.2.

Onshore site visits to confirm results of desk based study and identification of any additional targets of archaeological interest.

Potential Mitigation Methods

Potential mitigation measures for effects on heritage assets include micro-siting of OSPs and the export cable (offshore and onshore substations), choice of construction techniques and the use of a written scheme of investigation and protocol and procedures for unexpected archaeological discoveries.

The mitigation measures proposed for the TI development area will be dependent upon the final design of the site and the potential effects as determined by the EIA studies. With regard to physical effects, these will be avoided through design as far as is reasonably practicable. Where this is not possible provision will be made for the preservation of assets by record. Setting effects will be prevented or reduced through design, in particular landscaping of the substations. Mitigation options will be discussed with the relevant authorities.

In order to mitigate the risk of damage to any previously unrecorded archaeological remains, the draft Protocol for Archaeological Discoveries (PAD) that was included in the MORL ES (2012) will be discussed for the approval of Historic Scotland and Aberdeenshire Council Archaeologist to mitigate construction effects in the event of any unexpected archaeological discoveries during installation.

5.3.10 Socio-Economics, Recreation and Tourism

The following description of the baseline environment has been established through a desk based information gathering exercise, obtaining data from the following publications and websites:

- Caithness & North Sutherland Regeneration Partnership (2010). <http://www.cnsrp.org/>. Accessed 2010.
- The Highland Council (2010). <http://www.highland.gov.uk/>. Accessed 2010.
- Aberdeenshire Council (2008). Banff and Buchan Profile. Available from <http://www.aberdeenshire.gov.uk/statistics/area/index.asp>.
- Scottish Government (2010). <http://www.scotland.gov.uk/About/scotPerforms/indicators/electricity>.
- Visit Scotland (2011). <http://www.visitscotland.com/>. Accessed 2011.

Baseline Environment

In terms of socio-economic data, the closest published profile relates to the “Inner Moray Firth”, this is an area that includes Inverness and has a population of 144,000, which has been growing. Other main population centres on the coastline include Wick, Helmsdale, Brora, Golspie, Dornoch, Tain, Fortrose, Avoich, Inverness, Nairn, and Lossiemouth. For some of MORL’s proposed analysis (tourism and recreation) this is probably too wide a geographical area, but may be more relevant for labour markets. Employment is greatest in public administration, education and health accounting for over 30% of all employees in 2008. Manufacturing and construction are also relatively large employment sectors comprising of approximately 15% of the workforce. Unemployment in the Inner Moray Firth has tended to be lower than the Scottish average but has, however, risen since 2008, with 0.9% of the working age populace in long-term unemployment in 2010. Within the region, Inverness has the most number of people in long-term unemployment but Wick has the highest percentage (The Highland Council, 2010).

The main effects will relate to the potential additional economic activity that the project could bring and its associated employment and income, as well as any possible effects on tourism and other recreation (and associated employment). A large part of the employment and supply chain effect will stem from the construction phase. A critical part of understanding this is what is being constructed, how, by whom and where, as this will have direct potential effects on employment and income in the area and the rest of Scotland.

Within the northern section of the Highlands, the Caithness and North Sutherland Regeneration Partnership are taking forward a regional action plan to assist diversifying the economy of the region. Projects involved in this include development at Wick Harbour, development at Scrabster Harbour, Caithness engineering, the relocation of businesses to this area, transport connections and IT connectivity (CNSRP, 2010).

The Banff and Buchan regions form the northern section of the Aberdeenshire coastline. The main population centres along the coastline are Buckie, Banff and Fraserburgh. Statistics from 2008 indicated that, within Banff and Buchan, public services form the largest employment sector followed by manufacturing and, then distribution, hotels and restaurants. Construction accounts for approximately 5% of employment. In 2007, unemployment with Banff and Buchan accounted for 27.8% of unemployment with Aberdeenshire (Aberdeenshire Council, 2008).

The development of OfTI can have an effect on the local economy through local spend, use of services and goods and employment. The economic effect is likely to be most significant during the construction phase and given current programming for the development of sites, the effect will be spread over many years, and will conceivably extend up to 2021 and beyond. As well as economic benefits, wider beneficial effects will arise through the development of renewable energy, and will include reduced greenhouse gas emissions and education opportunities.

LAND USE, RECREATION AND TOURISM

The development area is bounded to the west by the eastern coastline of the Highlands and to the south by the northern coastline of the Grampians and Aberdeenshire.

The Moray coastline to the north is sparsely populated and to the south supports numerous traditional fishing villages. Local harbours support both fishing and recreational sailing activities.

It is possible that specific sectors, such as commercial fisheries, tourism and recreation, will have concerns regarding the knock-on economic effects of wind farm development, resulting from, for example, restricted access to fishing grounds or altered visual character.

Recreational and tourist attractions in the vicinity of the Moray Firth include:

FISHING

Sea angling and river fishing are both popular recreational activities in the highlands. Fly fishing, bait fishing, bank or boat, salmon, trout, rainbows, Loch or Sea.

WILDLIFE OBSERVATIONS

The Moray coastline is species diverse and is a favorite destination for Scotland's nature enthusiasts and for those travelling from further afield.

While the coast is focused on seabird and sea mammal observations, inland attractions include country parks such as the Highland Wildlife Park.

WALKING

The highlands feature an extensive network of walking tracks. The area offers some of Europe's most spectacular and diverse wilderness areas and is of interest to walkers due to its geology, arctic-alpine flora, and wildlife.

WATER SPORTS

The Moray Firth Water Sports Association is based on the West Beach, Lossiemouth. The group offers river and sea kayaking, including trips down the river Spey and surf breaks at Sandend and Lossiemouth throughout the year.

Other water sports include sailing, windsurfing, diving, waterskiing and wakeboarding.

GOLFING

The Moray Firth area features popular golf clubs at Elgin, Moray (old and new courses), Fraserburgh, Forres, Granton-on-Spey, Hopeman and Nairn Dunbar.

Nearby Inverness airport allows these golf courses to be easily accessible to Scotland's and the international golfing community.

Data Gaps

It is considered that local, regional and national Government and other relevant stakeholder groups hold sufficient data for the region.

Further data will be obtained from the following sources:

- Annual and Mid-year population estimates
- Annual Survey of Hours and Earnings
- ONS Sub-national population projections
- BRES (Formerly Annual Business Inquiry)
- SE's regional baseline studies; consultations (to be identified as study progresses)
- Online National Statistics/Scottish Annual Business Statistics
- Higher Education Statistics Agency (HESA)
- Desk research and consultations (to be identified as study progresses)
- Visit Scotland, potentially Local Authorities which have access to STEAM data, Visitor Attraction Monitor data

Environmental Impacts Scoping

Based on available literature, the following are perceived to be the potential effects on marine recreation and amenity as a result of works associated with construction, operation and decommissioning of the TI

Effect Description	Potential site specific effect	Potential cumulative and/or in-combination Effect
Changes in land use. A temporary change in land use is expected within the footprint of the cable route works	✓	✓
Temporary effects on residents related to construction activities. These will be related to noise and dust, access restrictions and include potential disruption to existing services and utilities.	✓	✓
Changes to local employment opportunities	✓	✓
Changes to expenditure within the local economy associated with goods and services	✓	✓
Effects on economics of other marine users (e.g. fisheries or tourism/recreation)	✓	✓

The MORL OGS Scoping Report and MORL ES were published in August 2010 and August 2012 respectively. The potential socio-economic effects identified will be considered in conjunction to the site-specific impact assessment methodology outlined below.

Site-specific Impact Assessment Methodology

For each of the potential effects described above a survey or study and method of impact assessment is described in the table below.

Potential Effect(s)	<ul style="list-style-type: none"> - Changes in land use - Temporary effects on residents related to construction activities. - Changes to local employment opportunities - Changes to expenditure within the local economy associated with goods and services - Effects on economics of other marine users (e.g. fisheries or tourism/recreation)
Survey/Study Proposed to Assess Effect	<p>To determine the potential for effects on socio-economic receptors, the following studies will be undertaken:</p> <ul style="list-style-type: none"> - Review of the national and regional economy - Review of regional socio-economic strategies - Review of socio-economic effects associated with offshore wind development - Desk research and consultations (as listed under Data Gaps above)
Method of Impact Assessment	<p>The key method of assessment will be to undertake a literature review of available information on socio-economic receptors along the east coast of Scotland and will follow the same methodology as undertaken for the MORL ES (MORL, 2012). This review will be coupled with consultation and effect assessment modelling, taking account of the planning/construction, operation and maintenance and decommissioning phases of the proposed Moray Firth development.</p>

Site specific survey methodology

BEST PRACTICE GUIDANCE

Guidance on the production of socio-economic analysis of offshore wind projects has not yet been produced and this introduces two important aspects to the methodology proposed by MORL. The first is that there are considerable overlaps between the areas covered by social, economic and environmental impact assessment, and they frequently affect each other. For example, the effects on tourism will partly depend on visual amenity and this is both economic, in that tourism may be increased or decreased which will then effect on income for tourism associated businesses and social if this then affects employment and quality of life. MORL has worked with socio-economic experts, the Scottish Government and the EU partners on the GPWIND project to help produce clearer guidance on what should be covered in this type of analysis. The outcomes of these discussions will inform MORL's proposed approach to socio-economic effect considerations, as appropriate and as undertaken in the MORL ES (MORL, 2012).

Summary of methodologies

The key method of assessment will be to undertake a literature review of available information on socio-economic receptors along the east coast of Scotland. This review will be coupled with consultation with relevant stakeholders.

For our purposes the baseline would be developed using a range of socio-economic quantitative and qualitative data covering the Highland area, including parts of the Moray coast.

The socio-economic impact assessment modelling will include the planning/construction, operation and maintenance and decommissioning phases of the development.

The models would use information from the developers on where expenditure would potentially be made and broadly on what. Estimates on how much would be retained in the local area, in Scotland and in the UK will be provided. This investment would support employment to varying degrees depending on the sector and this in turn would have further effects through the supply chain. The proportion of the expenditure retained in each area will also contribute to the Gross Value Added (GVA) produced.

As was agreed for the MORL ES (MORL, 2012), MORL's assessment of the potential tourism and recreation effect of the proposed developments will not seek to quantify, in financial terms, any effect on local tourism businesses. Instead, our approach will be to:

- **Review existing evidence** of how offshore energy installations have affected tourism in other areas of Scotland and further afield;
- **Assess the current profile of tourists and visitors** who travel to the local area in terms of numbers, spend, activities, reasons for visiting the region and so on;
- **Identify any direct effects on local tourism 'assets'** (e.g. public rights of way, paths, scenic areas or so on) which the new development may cause at the different stages; construction, operation, maintenance and decommissioning. Direct effects could include factors such as closure or diversion of access to tourism assets or the remove of those assets;
- **Identify indirect effects on local tourism assets.** In this case, indirect effects will mainly relate to changes in amenity through the permanent or temporary modification of land and seascapes and the visual effect of the installations and associated development. These potential indirect effects would be identified by first undertaking an audit of the tourism and recreation assets within a certain radius and then determining the indirect effect that the new development will have on those assets;
- **Assess potential effects on marine tourism and recreational yachting** – through consultation with appropriate representatives or businesses; and
- **Undertake a number of consultations with key tourism stakeholders and businesses** to understand their views and the potential effect it may have on tourism

Cumulative and In-combination Impact Assessment & Survey Methodologies

The methodologies and potential survey requirements by which cumulative and in-combination effects will be assessed will be agreed with consultees.

Both the BOWL and MORL projects would be included in the cumulative impact assessment. Consideration will be given to both the offshore and onshore aspects of the two offshore wind farm projects.

The cumulative effect, however, may not be the sum of the two individual projects. For the economic effect this will be reflected in the patterns of expenditure, where estimates would be expected to take account of any savings associated with proceeding with both developments. The study will have to identify the socio-economic aspects where the cumulative effects differ from the aggregate of the two projects.

Potential Mitigation Methods

Potential mitigation measures for any socio-economic effects identified will be site and region specific. The mitigation measures proposed for the development area will be dependent upon the final design of the site and the potential effects as determined by the EIA studies.

5.3.11 Traffic and Transport

Baseline Environment

This section will assess the potential environmental effects resulting from traffic and transport on the road network associated with the construction and operation of the offshore substations, offshore export cables, onshore export cables and onshore substations. Traffic generated by these will be associated with their construction and the delivery of components etc. There will not be any regular traffic generated by the operation of these and so the effects of traffic within the ES will be limited to that generated by their construction.

The assessments will be based upon the baseline environmental conditions which will be determined through a detailed site visit, an analysis of traffic flows and an analysis of Personal Injury Accident (PIA) Statistics.

Data Gaps

It is considered that sufficient data will be available on which to undertake the assessments to determine any likely environmental effects of road traffic.

Environmental Impacts Scoping

Based upon experience of other similar proposals, the following are considered to have a potential environmental effects:

Effect Description	Potential site specific effect	Potential cumulative and/or in-combination Effect
Increase in Traffic	✓	✓
Movement of Abnormal Loads	✓	✓

Site Specific Impact Assessment Methodology

Potential Effect(s)	Increase in Traffic
<p>Survey/Study Proposed to Assess Effect</p>	<p>A full assessment of the traffic and transport implications of the construction phases of the OSPs, offshore export cables, onshore export cables and onshore substations will be undertaken, in consultation with the relevant Road Departments and with Transport Scotland as appropriate. This will:</p> <ul style="list-style-type: none"> - provide details of proposed access routes to the site; - demonstrate the ability of these routes to accommodate all large loads through the preparation of swept path analyses; - identify existing (baseline) traffic flows on these routes; - assess Personal Injury Accident (PIA) Statistics along the access routes in order to assess road safety; - identify the increase in traffic numbers resulting from each phase of the project; - assess the increases relative to the baseline traffic flows using criteria derived from recognised guidance (IEMA, 1993); - identify potential environmental effects arising as a result of the increased traffic; and - where necessary, propose mitigation measures to manage the increased traffic in order to minimise the resulting environmental effects, including an outline traffic management plan.
<p>Method of Impact Assessment</p>	<p>Current guidance for assessing the environmental effects of road traffic is set out in '<i>Guidelines for the Environmental Assessment of Road Traffic, Guidance Note No. 1</i>', published by the Institute of Environmental Management and Assessment (IEMA) in 1993.</p> <p>The guidelines are based upon the forecast increase in traffic on a link resulting from proposed development and sets out thresholds upon which more detailed assessments should be undertaken. The guidelines suggest that more detailed assessments should be undertaken for links where traffic flows, or the number of HGVs, are predicted to increase by more than 30% as a result of proposed development. The guidelines suggest that in sensitive locations a 10% threshold should be used as a basis for undertaking assessments in more detail.</p> <p>Table 2.1 of the Guidelines goes on to state that where more detailed assessments are required the following should be considered:</p> <ul style="list-style-type: none"> - Noise; - Vibration; - Visual Effects; - Severance; - Driver Delay; - Pedestrian Delay; - Pedestrian Amenity; - Accidents and Safety; - Hazardous Loads; - Air Pollution; and - Dust and Dirt.

	<p>The environmental effect of road traffic resulting from the proposals will be assessed upon the local and wider road network in accordance with the above IEMA guidelines. Each link will be considered in isolation to determine whether it is deemed sensitive or not and the forecast change in traffic flow resulting from the proposals will be assessed against the relevant threshold, as identified by the IEMA. If any areas on the wider network route through sensitive areas, then the 10% threshold will be applied.</p> <p>Assessments will be undertaken across a typical working day. On any link where increases in traffic flow are in excess of the threshold a detailed assessment will be undertaken in accordance with Table 2.1 of the guidelines and set out above.</p> <p>The likely links which would be used to access the site are shown in Figure 5-23. Not all of these links will be used to transport material to the site at the same time, however, those being used will be assessed in accordance with the above guidance.</p>
--	---

Potential Effect(s)	Movement of Abnormal Loads
Survey/Study Proposed to Assess Effect	<p>A full assessment of the traffic and transport implications of transporting abnormal loads will be undertaken, in consultation with the relevant Road Departments and with Transport Scotland as appropriate. This will</p> <ul style="list-style-type: none"> - provide details of proposed access routes to the site for abnormal loads such as those associated with the transportation of sub-station components; - demonstrate the ability of these routes to accommodate all large loads through the preparation of swept path analyses; and - where necessary, propose any accommodation measures which may be required in order for abnormal loads to reach the site.
Method of Impact Assessment	<p>An Abnormal Loads Study will be undertaken to determine suitable routes to the site for all abnormal loads. This will comprise of a detailed site visit along the routes to measure road geometries and to rank the available routes to determine a preferred route option. Where necessary, accommodation measures will be determined to enable abnormal routes to reach the site.</p> <p>These routes will be discussed with the relevant Road Departments and with Transport Scotland as appropriate in order to agree suitable routes for abnormal loads.</p>

Site Specific Impact Survey Methodology

All assessments will be undertaken in accordance with current guidance for assessing the environmental effects of road traffic as set out in 'Guidelines for the Environmental Assessment of Road Traffic, Guidance Note No. 1', published by the Institute of Environmental Management and Assessment (IEMA) in 1993.

Additional Information

Access and egress solutions and route options will be subject to a full swept path analysis and further discussions with Road Authorities and Transport Scotland as appropriate.

Police Authorities, Transport Scotland and Road Departments are invited to comment on this Scoping Report, and will continue to be consulted during the process.

OTHER SURVEYS TO BE USED TO IDENTIFY EFFECTS

The above methodology will not require any other surveys in order to identify any effects.

Cumulative and In-Combination Impact Assessment and Survey Methodologies

In addition to assessing any environmental effects resulting from the construction of the OSPs, offshore export cables, onshore export cables and onshore substations, an assessment of any cumulative and in-combination effects will also be undertaken using the above methodology.

Potential Mitigation Methods

The above analyses will determine the significant effects of road traffic resulting from the proposals. If any significant effects are predicted then suitable mitigation measures will be discussed with the Road Departments and Transport Scotland and implemented as appropriate.

If the Abnormal Loads Study determines that accommodation measures are required along the access routes then these will be discussed with the Road Departments and Transport Scotland and implemented as appropriate.

Contains Ordnance Survey data © Crown Copyright and database right [2014].
Moray Offshore Renewables Ltd © 2014. This document is the property of contractors and sub-contractors and shall not be reproduced nor transmitted without prior written approval.

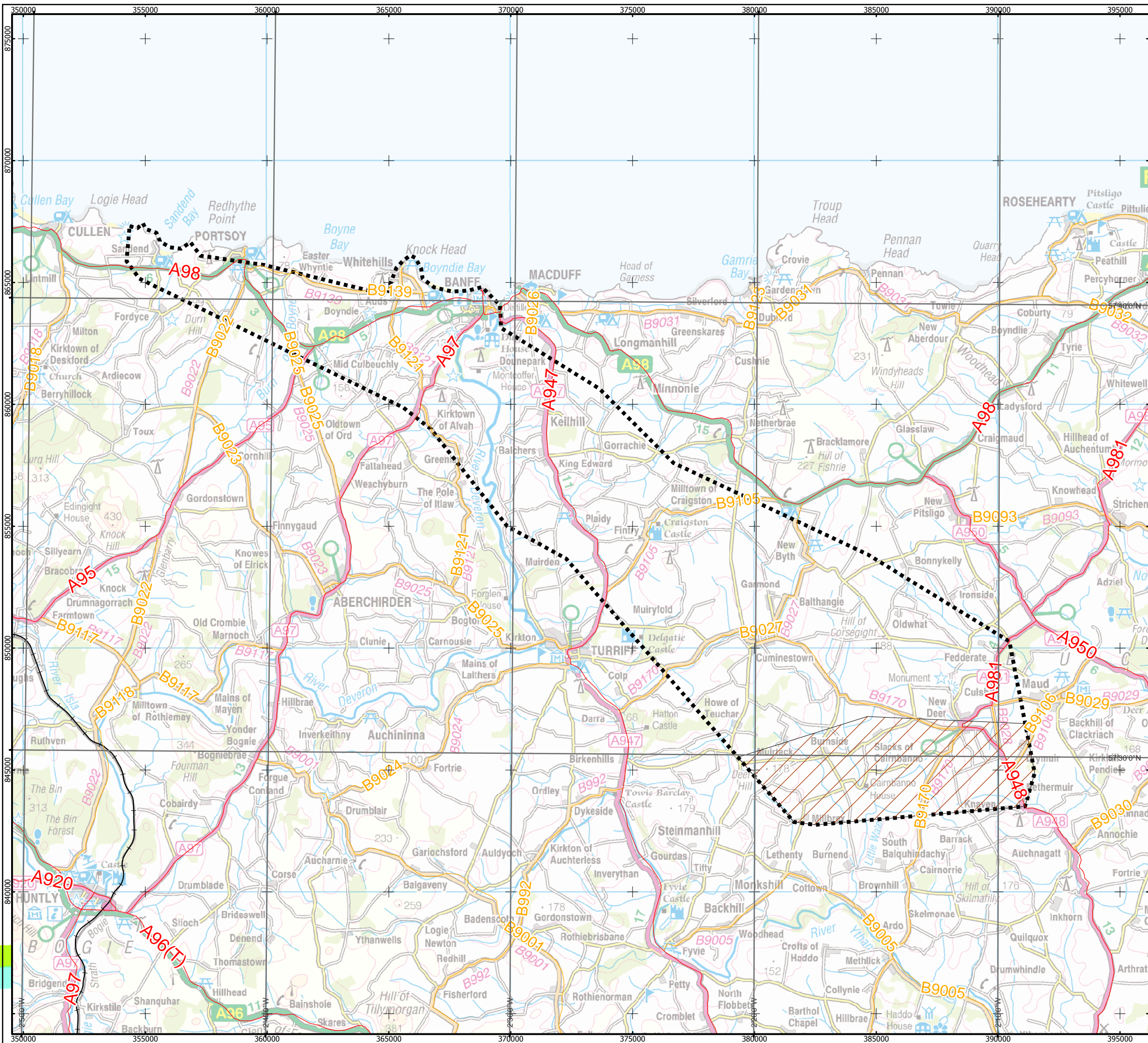

Moray Offshore Renewables Ltd

KEY

- A Road
- B Road
- Railway
- Onshore Substation Search Area
- Onshore Cable Corridor Search Area

Horizontal Scale: 1:150,000

A3 Chart

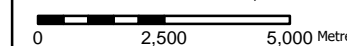

Geodetic Parameters: British National Grid

Produced: RH
Reviewed: PM
Approved: SP

Date: 02/04/2014 Revision: A
REF: 8460001-PSO0010-MOR-MAP-047

Fig 5-23 Transport Routes

Moray Offshore
Renewables Ltd

5.4 Structure of EIA

The Environmental Statement will update the current MORL ES in light of the modifications to the TI. It is likely to be presented in the following format:

Volume 1

Non Technical Summary

Volume 2

Preface

Section 1 – The Project

Chapter 1 - Project Background

- 1.1 Introduction
- 1.2 Regulatory and Policy Context
- 1.3 Environmental Impact Assessment
- 1.4 Stakeholder Consultation

Chapter 2 – Project Details

- 2.1 Assessment of Alternatives
- 2.2 Project Description

Section 2 – Description of the Environment

Chapter 3 – Physical Environment

- 3.1 Bathymetry
- 3.2 Geology
- 3.3 Wind Climate
- 3.4 Hydrodynamics (wave climate and tidal regime)
- 3.5 Sedimentary and Coastal Processes
- 3.6 Underwater Noise
- 3.7 Hydrology, Geology and Hydrogeology
- 3.8 Onshore Noise

Chapter 4 – Biological Environment

- 4.1 Designated Sites
- 4.2 Benthic Ecology
- 4.3 Fish and Shellfish Ecology
- 4.4 Marine Mammals
- 4.5 Ornithology
- 4.6 Intertidal Ecology
- 4.7 Terrestrial Ecology

Chapter 5 – Human Environment

- 5.1 Commercial Fisheries
- 5.2 Shipping and Navigation
- 5.3 Military and Civil Aviation
- 5.4 Seascape, Landscape and Visual Receptors

- 5.5 Archaeology and Visual Receptors
- 5.6 Socio-economics, Recreation and Tourism
- 5.7 Traffic and Transport
- 5.8 Other Human Activities

Volume 3

Section 3 – Transmission Infrastructure Impact Assessment

Chapter 6 – Physical Environment

- 6.1 Hydrodynamics (wave climate and tidal regime)
- 6.2 Sedimentary and Coastal Processes
- 6.3 Hydrology, Geology and Hydrogeology
- 6.4 Onshore Noise

Chapter 7 – Biological Environment

- 7.1 Benthic Ecology
- 7.2 Fish and Shellfish Ecology
- 7.3 Marine Mammals
- 7.4 Ornithology
- 7.5 Intertidal Ecology
- 7.6 Terrestrial Ecology

Chapter 8 – Human Environment

- 8.1 Commercial Fisheries
- 8.2 Shipping and Navigation
- 8.3 Military and Civil Aviation
- 8.4 Seascape, Landscape and Visual Receptors
- 8.5 Archaeology and Visual Receptors
- 8.6 Socio-economics, Recreation and Tourism
- 8.7 Traffic and Transport
- 8.8 Other Human Activities

Volume 4

Section 4 – Whole Project Impact Assessment

Chapter 9 – Whole Project Assessment

- 9.1 Whole Project Assessment
- 9.2 Habitat Regulations Appraisal Summary (if required)

Section 5 – Cumulative Impact Assessment

Chapter 10 – Physical Environment

- 10.1 Hydrodynamics (wave climate and tidal regime)
- 10.2 Sedimentary and Coastal Processes
- 10.3 Hydrology, Geology and Hydrogeology
- 10.4 Onshore Noise

Chapter 11 – Biological Environment

- 11.1 Benthic Ecology
- 11.2 Fish and Shellfish Ecology

- 11.3 Marine Mammals
- 11.4 Ornithology
- 11.5 Intertidal Ecology
- 11.6 Terrestrial Ecology

Chapter 12 – Human Environment

- 12.1 Commercial Fisheries
- 12.2 Shipping and Navigation
- 12.3 Military and Civil Aviation
- 12.4 Seascape, Landscape and Visual Receptors
- 12.5 Archaeology and Visual Receptors
- 12.6 Socio-economics, Recreation and Tourism
- 12.7 Traffic and Transport
- 12.8 Other Human Activities

Volume 6

Figures and Technical Appendices

6 References

Aberdeen City Council & Aberdeenshire Council (2009). Aberdeen City and Shire Strategic Plan. Aberdeen City and Shire Strategic Development Plan Team, Aberdeen. 32pp.

Aberdeenshire Council (2006). The Aberdeenshire Local Plan. Available from <http://www.aberdeenshire.gov.uk/planning/finalised/index.asp>.

Aberdeenshire Council (2008). Banff and Buchan Profile. Available from <http://www.aberdeenshire.gov.uk/statistics/area/index.asp>.

ANSI, S12.64, Quantities and Procedures for Description and Measurements of Underwater Sound from Ships, Acoustical Society of America, 2009.

BOWL (2012), Environmental Statement, Eastern Development Area and associated Transmission Infrastructure.

British Standards Institution. British Standard 5228: Code of practice for noise and vibration control on construction and open sites. Part 1: Noise. 2014.

British Standards Institution. British Standard 4142: Method for Rating industrial noise affecting mixed residential and industrial areas. 1997.

British Standards Institution. British Standard 8233: Sound insulation and noise reduction for buildings - Code of practice. 1999.

British Standards Institution. British Standard 7445: Description and measurement of environmental noise. Part 1: Guide to environmental quantities and procedures. 2003.

British Standards Institution. British Standard 7445: Description and measurement of environmental noise. Part 2: Guide to the acquisition of data pertinent to land use. 1991.

British Standards Institution. British Standard 7445: Description and measurement of environmental noise. Part 3: Guide to application to noise limits. 1991.

Caithness & North Sutherland Regeneration Partnership (2010). <http://www.cnsrp.org/>. Accessed 2010.

Canning, S.J. (2007). Cetacean distribution and habitat use along the east coast of Scotland. PhD Thesis. University of Aberdeen.

CNSRP (2010). <http://www.cnsrp.org/>. Accessed 2010.

COWRIE (2009) Coastal Process Modelling for Offshore Wind Farm Environmental Impact Assessment: Best Practice Guide. Lambkin, D.O., Harris, J.M., Cooper, W.S., Coates, T.

DECC (2009a). The UK Renewable Energy Strategy. HM Government. Available from: http://www.decc.gov.uk/en/content/cms/publications/lc_trans_plan/lc_trans_plan.aspx.

DECC (2009b). UK Offshore Energy Strategic Environmental Assessment. Future Leasing for Offshore Wind Farms and Licensing for Offshore Oil and Gas and Gas Storage. Environmental Report. January 2009.

DTI (2004). SEA 5: Strategic Environmental Assessment of Parts of the Northern and Central North Sea to the East of the Scottish Mainland, Orkney and Shetland. Department of Trade and Industry.

DTI (2005a). Guidance on the assessment of the impact of offshore wind farms: methodology for assessing the marine navigational safety risks of offshore wind farms. Department of Trade and Industry in association with Maritime & Coastguard Agency and Department for Transport. Available from <http://www.berr.gov.uk/files/file22888.pdf>.

DTI (2005b). Guidance on the assessment of the impact of offshore wind farms: Seascape and visual impact report. DTI/Pub 8066/0.3k/11/05/NP. Pp. 135.

Eleftheriou, A., Basford, D., & Moore, D.C. (2004). Synthesis of information on the benthos of area SEA 5. Report for the Department of Trade and Industry.

ERM (2011). Moray Firth Offshore Wind Developers Group, Cumulative Impacts Assessment Discussion Document. Prepared for Moray Offshore Renewables Ltd and Beatrice Offshore Windfarm Ltd. April 2011. For consultation.

European Commission (2007). Contribution to the interpretation of the strict protection of species (Habitats Directive article 12). A report from the Article 12 working group under the Habitats Committee with special focus on the protection of breeding sites and resting places (article 12 1 d).

Flather, R.A. (1987) Estimates of extreme conditions of tide and surge using a numerical model of the north-west European continental shelf. *Estuarine, Coastal and Shelf Science*, 24, 69-93.

Forestry Commission Scotland. Forest Operations and Red Squirrel in Scottish Forests. FCS Guidance Note 33, November 2006

Hall-Spencer, J. & Stephes, K. (2009). Background document for *Lophelia pertusa* reefs. OSPAR Commission, 423/2009, 32 pp. ISBN 978-1-906840-63-1.

Hammond, P.S., Northridge, S.P., Thompson, D., Gordon, J.C.D., Hall, A.J., Sharples, R.J., Grellier, K. & Mathiopoloulos, J. (2004). Background information on marine mammals relevant to Strategic Environmental

Assessment 5. Strategic Environmental Assessment – SEA5 Technical Report for Department of Trade & Industry.

Hastie, G.D., Wilson, B. & Thompson, P.M. (2003). Fine-scale habitat selection by coastal bottlenose dolphins: application of a new land-based video-montage technique. *Canadian Journal of Zoology*. 81: 469–478.

Health & Safety Executive Report (2002). Offshore Technology Report, Environmental Considerations. Report 2001/010, ISBN 0 7176 2379 3.

Holmes, R., Bulat, J., Henni, P., Holt, J., James, C., Kenyon, N., Leslie, A., Long, D., Morri, C., Musson, R., Pearson, S., & Stewart, H. (2004) DTI Strategic Environmental Assessment Area 5 (SEA5): Seabed and Superficial Geology and Processes. Commercial Report CR/04/064N

Jennings, S., Lancaster, J., Woolmer, A. & Cotter, J. (1999). Distribution, diversity and abundance of epibenthic fauna in the North Sea. *Journal of the Marine Biological Association of the United Kingdom*: 79, 385-399.

JNCC. (2007). Handbook for Phase 1 Habitat Survey, A Technique for Environmental Audit. Joint Nature Conservation Committee, Peterborough.

(JNCC), Natural England and Countryside Council for Wales. (2010). The protection of marine European Protected Species from injury and disturbance: Guidance for the marine area in England and Wales and the UK offshore marine area, June 2010.

JP Kenny (2011) Work Package 7 – Concept Report. Prepared for Moray Offshore Renewables Ltd. March 2011.

McConnell, B.J., Fedak, M.A., Lovell, P. & Hammond, P.S. (1999). Movements & foraging areas of grey seals in the North Sea. *Journal of Applied Ecology*. 35: 573-590.

Marine Scotland (2010). The Plan for Offshore Wind Energy in Scottish Territorial Waters (STW). Strategic Environmental Assessment Environmental Report (ER): Volume 1.

Metoc-Hyder (2011). Moray Firth Offshore Windfarm Export Cable Route Feasibility Study. Prepared for Moray Offshore Renewables Ltd. January 2011.

Moray Offshore Renewables Ltd (2010). Environmental Impact Assessment Report, Eastern Development Area. Offshore Infrastructure: Offshore Wind Turbines, Substations & Interarray Cables.

Moray Offshore Renewables Ltd (2011). Environmental Impact Assessment Report, Transmission Infrastructure: Offshore substations, Offshore export cables, onshore export cables & onshore substation.

Moray Offshore Renewables Ltd (2012) Environmental Statement, Eastern Development Area and associated Transmission Infrastructure.

Nedwell, J. R., Turnpenny, A.W.H., Lovell, J., Parvin, S.J., Workman, R., Spinks, J.A.L., Howell, D. (2007). A validation of the dBht as a measure of the behavioural and auditory effects of underwater noise. Subacoustech Report Reference: 534R1231, Published by Department for Business, Enterprise and Regulatory Reform

Oldham R.S., Keeble J., Swan M.J.S & Jeffcote M. (2000). Evaluating the suitability of habitat for the Great Crested Newt (*Triturus cristatus*). *Herpetological Journal* 10 (4), 143-155

Ratcliffe, D. A. (1977). *A Nature Conservation Review*. Cambridge University Press, Cambridge.

Rodwell, J.S (2006). National Vegetation Classification: Users' Handbook. Joint Nature Conservation Committee, Peterborough.

SCOS (2009). Scientific advice on matters related to the management of seal populations: 2009. Sea Mammal Research Unit, St Andrews, Scotland.

Scott, K.E., Anderson, C., Dunsford, H., Benson, J.F. & MacFarlane, R. (2005). An assessment of the sensitivity and capacity of the Scottish seascape in relation to offshore windfarms. Scottish Natural Heritage Commissioned Report No. 103. (ROAME No. F03AA06). Available from:
http://www.snh.org.uk/pdfs/publications/commissioned_reports/F03AA06.pdf.

Senergy (2009). Zone 1 offshore windfarm – preliminary site evaluation. Conducted for SeaEnergy Renewables. Reference No. 1502-SER-RPT-01-02. Senergy Survey and GeoEngineering.

SEPA. (2004a). Superficial Aquifer map. SEPA.

SEPA. (2004b). Bedrock Aquifer map. SEPA.

SEPA. (2004c). Groundwater Vulnerability of the Uppermost Aquifer Map of Scotland. SEPA.

SEPA. (2007). Scotland Drinking Water Protected Areas (Groundwater). SEPA.

SEPA. (2007). Scotland Drinking Water Protected Areas (Surface Water) . SEPA.

Smith, W. H. F., and D. T. Sandwell. (1997). "Global Seafloor Topography from Satellite Altimetry and Ship Depth Soundings", Science, v. 277, p. 1957-1962, 26 Sept., 1997.

Scottish Natural Heritage (SNH) (2001). Scotland's Wildlife: Badgers and Development.
<http://www.snh.org.uk/publications/on-line/wildlife/badgersanddevelopment/development.asp>

SNH (2006a). Assessing Significance of Impacts from Onshore Windfarms on Birds Outwith Designated Areas. SNH Guidance Note, SNH, Edinburgh.

SNH (2006b). Assessing Significance of Impacts from Onshore Windfarms on Birds Outwith Designated Areas: Basis for the Guidance in European and National Legislation, and Government Policy. SNH Information Paper, SNH, Edinburgh.

Scottish Natural Heritage (SNH) (2008). Otters and Development. Scottish Wildlife Series.
<http://www.snh.org.uk/publications/on-line/wildlife/otters/default.asp>

Southall, Brandon L.; Bowles, Ann E.; Ellison, William T.; Finneran, James J.; Gentry, Roger L.; Greene, Charles R.; Kastak, David; Ketten, Darlene R.; Miller, James H.; Nachtigall, Paul E.; Richardson, W. John; Thomas, Jeanette A.; Tyack, Peter L, (2007). Marine Mammal Noise Exposure Criteria Aquatic Mammals, Vol 33 (4).

The Highland Council (2010). <http://www.highland.gov.uk/>. Accessed 2010.

The Scottish Government. Planning Advice Note: PAN 1 Planning and Noise. The Scottish Office. March 2011.

The Scottish Government. Technical Advice Note: Assessment of Noise TANAN 11 The Scottish Office. March 2011.

The Scottish Government (2011).<http://www.scotland.gov.uk/news/releases/2011/05/18093247>

Thompson, P.M. & Miller, D. (1990). Summer foraging activity and movements of radio-tagged common seals (*Phoca vitulina*) in the Moray Firth, Scotland. *Journal of Applied Ecology*. 27: 492-501.

UKBAP (2010). <http://www.ukbap.org.uk/ukplans.aspx?ID=123>.

Visit Scotland (2011). <http://www.visitscotland.com/>. Accessed 2011.

Ware, S.J. & Kenny, A.J. (2011). Guidelines for the conduct of benthic studies at marine aggregate extraction sites. 2nd edition. Marine Aggregate Sustainability Fund 80pp.

Moray Offshore Renewables
EDPR UK
40 Princes Street
Edinburgh
EH2 2BY

Email: info@morayoffshorerenewables.com



moray offshore renewables ltd