

WORK IN PROGRESS
FOR INFORMATION ONLY

ISSUE/REVISION		
P01	18/02/19	First Issue
I/R	DATE	DESCRIPTION

PROJECT NUMBER
60536743

SHEET TITLE
MARINE LICENCE
MARSHALLING AREA
HEADWALL
DETAILS

SHEET NUMBER
UHRD-ACM-ZZ-GE-DR-MT-10152

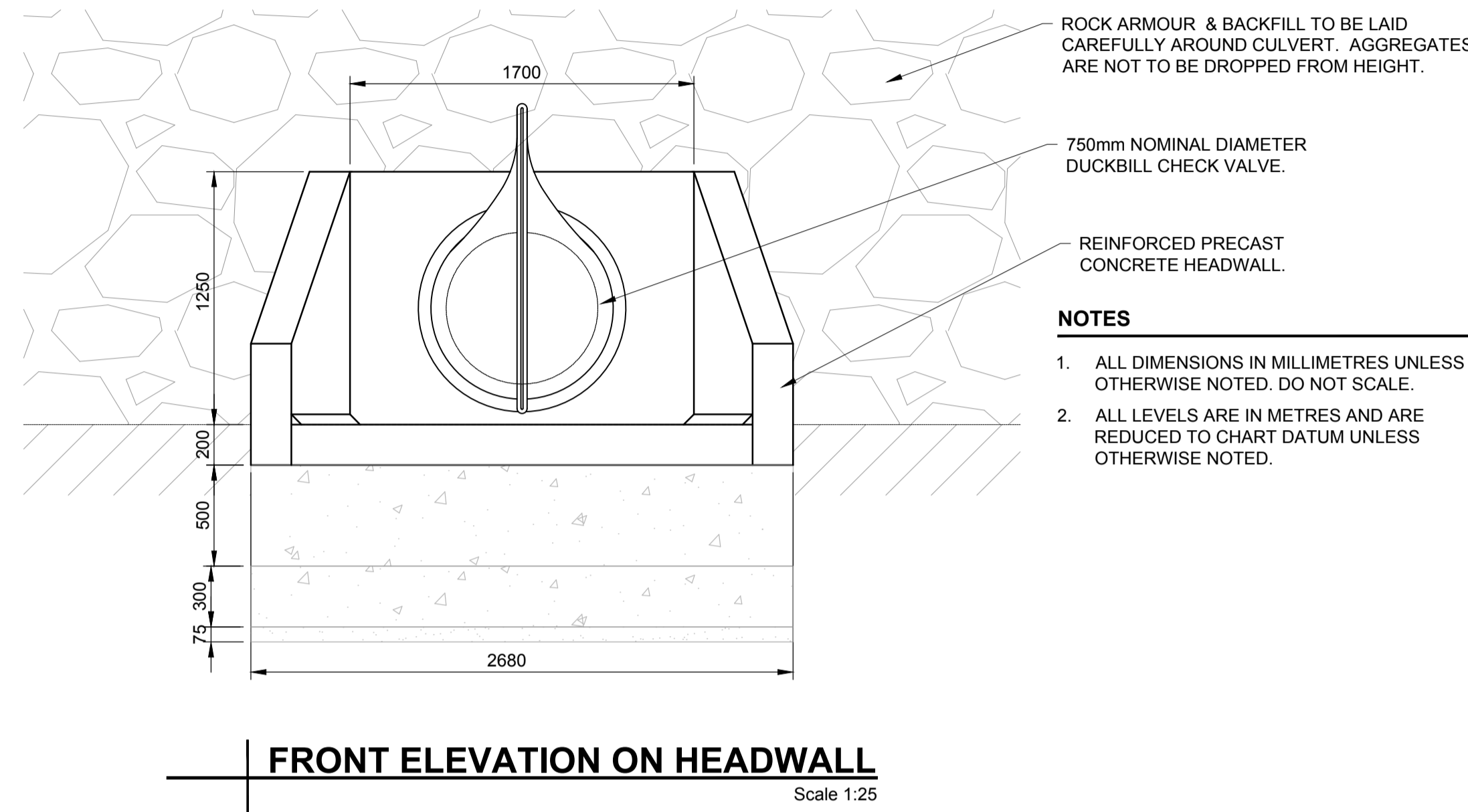
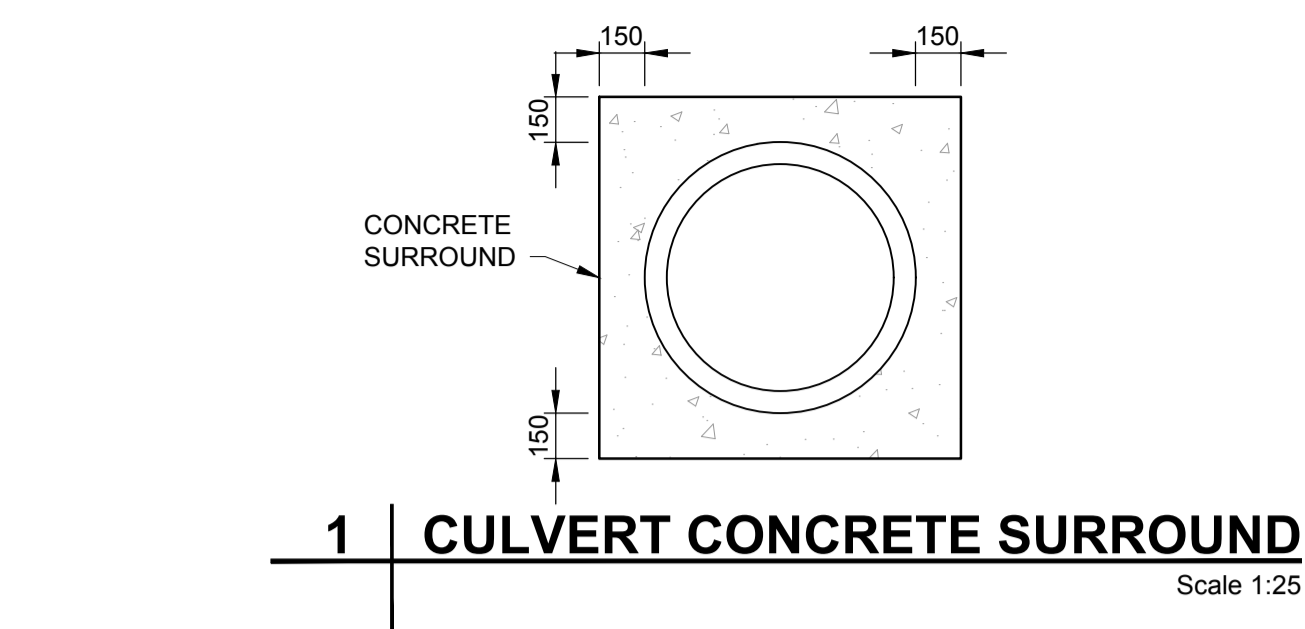

- NOTES**
1. ALL DIMENSIONS IN MILLIMETRES UNLESS OTHERWISE NOTED. DO NOT SCALE.
 2. ALL LEVELS ARE IN METRES AND ARE REDUCED TO CHART DATUM UNLESS OTHERWISE NOTED.

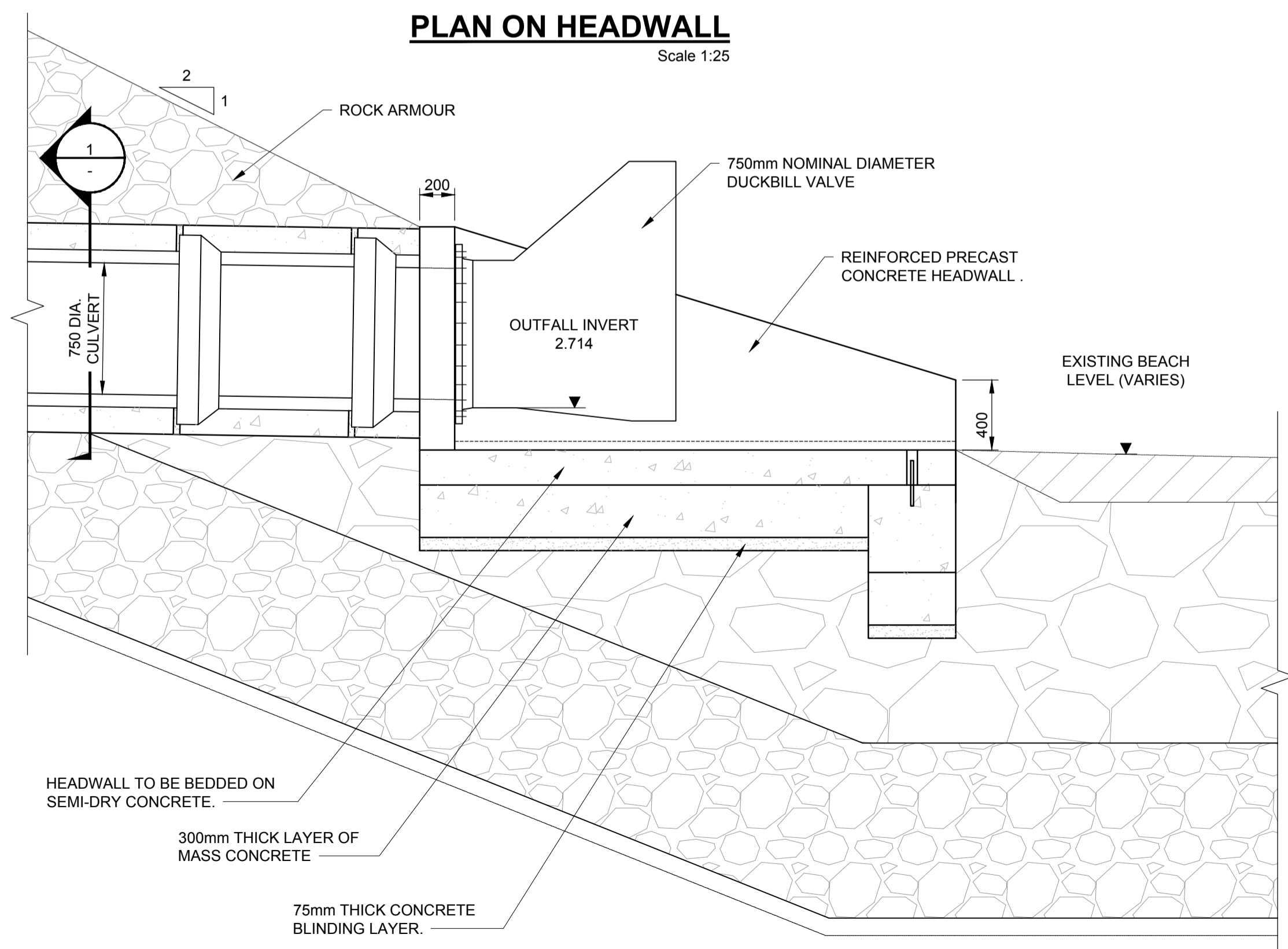
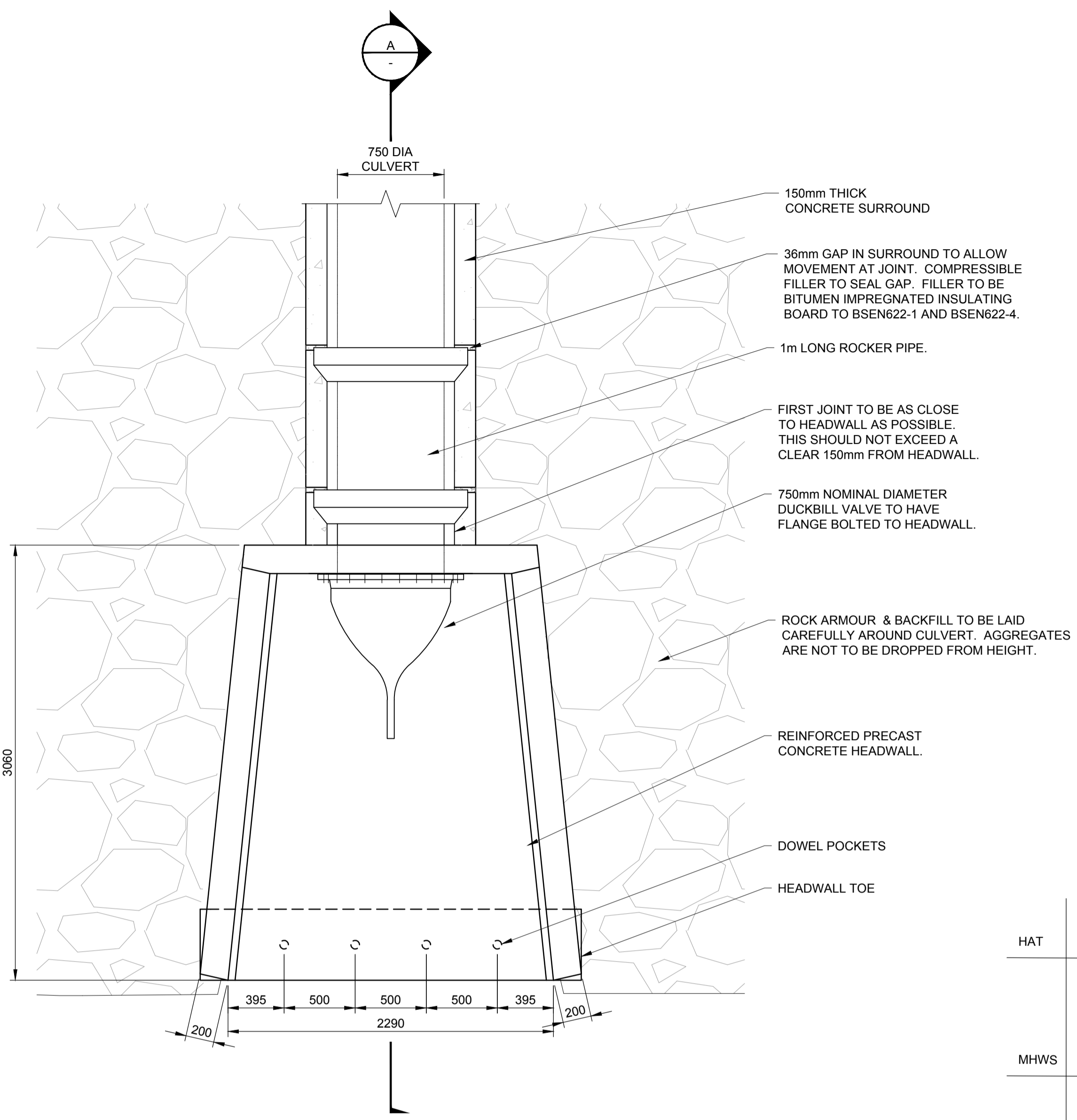

HAT	6.13m
MHWS	5.30m
MHWN	3.50m
MLWN	1.90m
MLWS	0.70m
LAT	0.10m

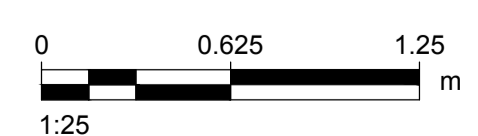

This drawing has been prepared for the use of AECOM's client. It may not be used, modified, reproduced or relied upon by third parties, except as agreed by AECOM or as required by law. AECOM accepts no responsibility and denies any liability whatsoever to any party that uses or relies on this drawing without AECOM's express written consent. Do not scale this document. All measurements must be obtained from the stated dimensions.