

**Moray Offshore Windfarm (West) Limited  
Construction Programme and Construction Method  
Statement**



8460005-DBHA03-MWW-PLN-000001

**MORAY OFFSHORE WINDFARM (WEST) LIMITED**

# **Construction Programme & Construction Method Statement**

**Document Name: 8460005-DBHA03-MWW-PLN-000001**

**Revision: 09**

**Status: Final**

**Date: 28-08-2024**

**Moray Offshore Windfarm (West) Limited**  
**Construction Programme and Construction Method**  
**Statement**



8460005-DBHA03-MWW-PLN-000001

Version Control				
Revision	Date	Status	Revision Description	Distribution List
01	20-03-22	Draft	Submission to Moray West for review	Moray West
02	17-05-22	Draft	Second Internal Review	Moray West
03	19-05-22	Final	Submission to MS-LOT	MS-LOT
04	05-07-22	Final	Second submission to MS-LOT	MS-LOT
05	03-11-22	Final	Third submission to MS-LOT	MS-LOT
06	16-11-22	Final	Fourth submission to MS-LOT	MS-LOT
07	06-09-23	Final	Fifth submission to MS-LOT	MD-LOT
08	18-12-23	Final	Sixth submission to MD-LOT	MD-LOT
09	28-08-24	Final	Seventh submission to MD-LOT	MD-LOT

Document Approval (Rev 06)				
Prepared by:	ECoW Review by:	Legal Review by:	Approved by:	Approved by:
RHDHV (Alexia Chapman)	RHDHV (Erin Snaith)	Shepherd and Wedderburn (Scott McCallum)	Catarina Rei (Senior Development Manager)	Adam Morrison (Project Director)

# Moray Offshore Windfarm (West) Limited Construction Programme and Construction Method Statement



8460005-DBHA03-MWW-PLN-000001

## Plan Overview

This Construction Programme (CoP) and Construction Method Statement (CMS) document has been prepared to address the specific requirements of the relevant conditions attached to the Section 36 (S36) consent and Marine Licences (collectively referred to as the 'offshore consents') issued to Moray Offshore Windfarm (West) Limited (Moray West). The overall objective of the CoP and CMS is to set out the intended construction programme and construction method statement, including good working practices, for the Moray West Offshore Windfarm and Offshore Transmission Infrastructure (OfTI) (collectively referred to as 'the Development').

The CoP and CMS confirms that the construction programme and procedures to be employed align with those considered in the original Application, and that construction-related mitigation measures detailed in the Application will be applied during installation.

All Moray West personnel and contractors involved in the Development must comply with this CoP and CMS.

## Scope of the Plan

In line with the requirements of the offshore consent conditions, along with industry standards and good practice, the CoP and CMS covers the following:

- the proposed dates for commencement of construction;
- the proposed details of mobilisation of plant and delivery of materials;
- the proposed dates, durations and sequencing of construction work for all key elements of the Development;
- contingency planning for poor weather or other unforeseen delays;
- the scheduled date for final commissioning of the Development;
- construction procedures in relation to piled foundations and support structures, wind turbines, offshore substation platforms, and inter-array, inter-connector, and export cables;
- good working practices to be employed during construction; and
- the roles and responsibilities of key Development personnel and contractors during construction with respect to environmental management.

# Moray Offshore Windfarm (West) Limited Construction Programme and Construction Method Statement



8460005-DBHA03-MWW-PLN-000001

## Plan Audience

The CoP and CMS is intended to be referred to by personnel involved in the construction of the Development, including Moray West personnel and contractors. All method statements produced in relation to the Development must comply with this CoP and CMS.

Compliance with this CoP and CMS will be monitored by the Moray West Development Team, Moray West's Environmental Clerk of Works (ECoW), and Marine Directorate Licensing Operations Team (MD-LOT).

## Plan Locations

The latest version of this CoP and CMS can be obtained from Moray West's document management system, Viewpoint For Projects and from the Marine Scotland Information website<sup>1</sup>. In addition, copies of this document are to be held in the following locations:

- Moray West's main project office in Edinburgh;
- With the Moray West Marine Coordinator (MC); and
- with the ECoW(s).

---

<sup>1</sup> <https://marine.gov.scot/ml/moray-west-offshore-windfarm>

# Moray Offshore Windfarm (West) Limited Construction Programme and Construction Method Statement



8460005-DBHA03-MWW-PLN-000001

## Table of Contents

1	Introduction .....	9
1.1	Background .....	9
1.2	Objectives of the Plan .....	9
1.3	Linkages with other Consent Plans .....	9
1.4	Document Structure and Control.....	11
2	Construction Programme.....	12
2.1	Key Milestone Dates .....	12
2.2	Wind Farm Site Construction Programme .....	15
2.3	Offshore Transmission Infrastructure Construction Programme .....	17
2.4	Contingency Planning.....	19
3	Construction Roles and Responsibilities .....	20
3.1	Key Contractors.....	23
4	Construction Methods and Procedures .....	25
4.1	Introduction .....	25
4.2	Pre-Construction Seabed Preparation .....	25
4.3	Scour Protection Installation .....	27
4.4	Foundation Installation .....	27
4.5	Offshore Substation Platform Topsides .....	35
4.6	Inter-Array and OSP Inter-connector Cable Installation .....	37
4.7	Wind Turbine Generator Installation.....	44
4.8	Offshore Export Cable Installation .....	48
4.9	Electrical Infrastructure Commissioning.....	53
5	Good Working Practices.....	54
5.1	Introduction .....	54
5.2	Offshore Renewable Industry Good Working Guidance.....	54
5.3	Construction Management Procedures.....	56

# Moray Offshore Windfarm (West) Limited Construction Programme and Construction Method Statement



8460005-DBHA03-MWW-PLN-000001

5.4	Environment Management Measures .....	57
5.5	Project-Specific Good Working Practices.....	57
Appendix A – Defined Terms .....		60
Appendix B – Development Background Information .....		62
B.1	Development Description .....	62
B.2	Legal Context .....	64
B.3	Sustainable Construction .....	67

**Moray Offshore Windfarm (West) Limited**  
**Construction Programme and Construction Method**  
**Statement**



8460005-DBHA03-MWW-PLN-000001

## Abbreviations and Acronyms

Acronym / Abbreviation	Description
AEZ	Archaeological Exclusion Zone
CaP	Inter Array Cable Plan
CBRA	Cable Burial Risk Assessment
CLV	Cable Lay Vessel
CMS	Construction Method Statement
CoP	Construction Programme
CPS	Cable Protection System
CTV	Crew Transfer Vessel
DS	Design Statement
DSLp	Development Specification and Layout Plan
EcoW	Ecological Clerk of Works
ECP	Export Cable Plan
EMP	Environmental Management Plan
ERCoP	Emergency Response Cooperation Plan
EPS	European Protected Species
FLO	Fisheries Liaison Officer
HDD	Horizontal Directional Drilling
HDPE	High-Density Polyethylene
HLV	Heavy Lift Vessel
HVAC	High Voltage Alternating Cables
IAC	Inter-Array Cable
IDP	Intermediate Delivery Port
JUV	Jack-Up Vessel
LAT	Lowest Astronomical Tide
LMP	Lighting and Marking Plan
MBES	Multibeam Echosounder
MC	Marine Coordinator
MHWS	Mean High Water Spring
MPCP	Marine Pollution Contingency Plan
MD-LOT	Marine Directorate Licensing Operations Team
NOTAM	Notice to Airmen
NtM	Notice to Mariners
OEC	Offshore Export Cable
OfTI	Offshore Transmission Infrastructure
OFTO	Offshore Transmission Owner
ONEC	Onshore Export Cable

# Moray Offshore Windfarm (West) Limited Construction Programme and Construction Method Statement



8460005-DBHA03-MWW-PLN-000001

Acronym / Abbreviation	Description
OSP	Offshore Substation Platform
PAD	Protocol for Archaeological Discoveries
PLGR	Pre-Lay Grapnel Run
PS	Piling Strategy
QHSE	Quality, Health, Safety and Environment
ROV	Remotely Operated Vehicle
S36	Section 36
SSS	Side Scan Sonar
TJB	Transition Joint Bay
UKHO	UK Hydrographic Office
USBL	Ultra-Short Baseline
UXO	Unexploded Ordnance
VMNSP	Vessel Management and Navigational Safety Plan
W2W	Walk-to-Work
WSI	Written Scheme of Investigation
WTG	Wind Turbine Generator



# Moray Offshore Windfarm (West) Limited Construction Programme and Construction Method Statement



8460005-DBHA03-MWW-PLN-000001

## 1 Introduction

### 1.1 Background

The Moray West Offshore Wind Farm and associated Offshore Transmission Infrastructure (OfTI) (referred to as 'the Development') is being developed by Moray Offshore Windfarm (West) Limited (known as 'Moray West'; see Appendix A for defined terms). Consent for the Development was granted on 14 June 2019 under Section 36 (S36) of the Electricity Act 1989 (as amended), Part 4 of the Marine (Scotland) Act 2010 and the Marine and Coastal Access Act 2009 from Scottish Ministers. One S36 consent was granted by Scottish Ministers for the wind farm (012/OW/MORLW-8) and two Marine Licences were granted by Scottish Ministers, one for the Wind Farm and another for the offshore transmission infrastructure (OfTI).

Variations of the S36 consent and Wind Farm Marine Licence were granted by the Scottish Ministers on 7 March 2022, and further variations were granted of the Wind Farm Marine Licence (licence number: MS-00009774) on 11 April 2022 and OfTI Marine Licence (licence number: MS-00010585) on 11 April 2022 and 8 February 2024. The revised S36 consent and associated Marine Licences are referred to collectively as 'offshore consents'.

Further details of Moray West and the Development can be found in Appendix B.

### 1.2 Objectives of the Plan

Offshore consent conditions require the production of a Construction Programme (CoP; Condition 9 of S36 and Marine Licences MS-00009774 and MS-00010585 conditions 3.2.2.6 and 3.2.2.5 respectively) and Construction Method Statement (CMS; Condition 10 of S36 and Marine Licences MS-00009774 and MS-00010585 conditions 3.2.2.7 and 3.2.2.6 respectively).

The purpose of the CoP and CMS is to set out the intended construction programme, procedures and good working practices during the construction of the Development (but excluding decommissioning). The relevant conditions setting out the requirement for the CoP and CMS for approval, and which are to be discharged by this document, are presented in full in Appendix B (Table B.1).

### 1.3 Linkages with other Consent Plans

The CoP and CMS is part of a group of approved documents that provide the framework for the construction process. The other plans named in the relevant consents clearly have a link to the CoP and CMS document in so far as they either provide additional details on the construction methodology or provide details on the control of construction to mitigate or manage potential environmental impacts and impacts on other marine users.

Table 1 lists the Consent Plans with linkages to this CoP and CMS document.

# Moray Offshore Windfarm (West) Limited Construction Programme and Construction Method Statement



8460005-DBHA03-MWW-PLN-000001

Table 1 CoP and CMS linkage with other Consent Plans	
Other Consent Plans and Documents	Linkage with CoP and CMS
Design Statement (DS)	The DS includes representative wind farm visualisations from key viewpoints as agreed with the Scottish Ministers. This is based upon the final Development Specification and Layout Plan (DSLPL) as approved by the Scottish Ministers.
Development Specification and Layout Plan (DSLPL)	The DSLPL provides information about the Moray West Site including a detailed plan of WTG layout, seabed information, details on WTG dimensions, generating output of each WTG, as well as details on inter-array cabling.
Wind Farm Cable Plan (CaP)	The Wind Farm CaP and ECP provide details on the specification, location and installation techniques of the inter array, OSP inter-connect and export cables. This includes the results of surveys to inform cable routing, a burial risk assessment, methodologies for survey and monitoring of the cables during the operational phase and reporting requirements to Marine Directorate Licensing Operations Team (MD-LOT).
Export Cable Plan (ECP)	
Environmental Management Plan (EMP)	The EMP sets out the environmental framework for the construction and operation of the Wind Farm and OfTI infrastructure. It also contains the Marine Pollution Contingency Plan (MPCP) which sets out the procedure should an oil spill occur during construction. The installation and construction described within this CoP and CMS will be undertaken in line with the environmental management measures as described in the EMP.
Emergency Response Cooperation Plan (ERCoP)	The ERCoP describes the agreed measures for emergency response with the MCA.
Lighting and Marking Plan (LMP)	The LMP provides details of the aviation and navigational lighting and marking arrangements for the Development during construction and operation phases.
Piling Strategy (PS)	Piling methods and programme are detailed and includes the mitigation of the effects on noise sensitive species.
Vessel Management and Navigational Safety Plan (VMNSP)	Provides the management and coordination of vessels to mitigate the impact of vessels.
Fisheries Management and Mitigation Strategy (FMMS)	The FMMS provide information on mitigation measures to be followed during construction, including a Code of Good Practice for Contracted Vessels and Commercial Fishing Interaction Standard Operating Procedures

# Moray Offshore Windfarm (West) Limited Construction Programme and Construction Method Statement



8460005-DBHA03-MWW-PLN-000001

## 1.4 Document Structure and Control

The structure of this CoP and CMS is provided in Table 2.

Table 2 CoP and CMS document structure		
Section	Title	Summary of Content
1	Introduction	An overview of the Development and its associated consent requirements, and an introduction to this CoP and CMS.
2	Construction Programme	Provides an overview of the key milestone dates during the construction of the offshore aspects of the Moray West Development.
3	Construction Roles and Responsibilities	Defines the roles, responsibilities and communications of the Development's external and internal teams.
4	Construction Methods and Procedures	Provides further details on each step of the installation process for the offshore aspects of the Development.
5	Good Working Practices	Sets out the good working practices that will be applied during the installation process of the Development.
Appendix A	Defined Terms	Defines the terms to be used throughout this document.
Appendix B	Project Background Information	Detailed information of the Development. Including the construction programme, key stakeholders and legal context associated with the Development.

### 1.4.1 Document Control

This CoP and CMS is a 'live document' and will be revised as relevant to ensure the information is kept up to date with any revisions being notified to the Scottish Ministers as soon as practicable and any proposed material revisions being subject to prior approval by the Scottish Ministers.

Linkages exist between a number of offshore consent plans as highlighted in Section 1.3 within Table 1. As plans are updated, there will be a review of inter-linkages with other consent plans to ensure these are also updated as relevant. The document is controlled via Viewpoint For Projects, an electronic document management system.

# Moray Offshore Windfarm (West) Limited Construction Programme and Construction Method Statement



8460005-DBHA03-MWW-PLN-000001

## 2 Construction Programme

This section sets out the proposed programme for construction of the Wind Farm and OfTI and presents the key milestone dates for the commencement of the Development construction works, the main construction activities and the commissioning of the Development.

### 2.1 Key Milestone Dates

The key milestone dates associated with the construction activities are presented in Table 3 and Figure 2-1. Dates presented in this section may be subject to some changes to take account of delivery of Wind Farm and OfTI components, vessel availability, and minor operational refinements. Any changes to the dates presented in this CoP will be notified to MD-LOT and incorporated into future revisions of this CoP as required.

Offshore construction works will be carried out year-round and on a 24-hour, 7-day per week basis unless otherwise stated.

Table 3 Key Milestones Dates	
Milestone	Anticipated Programme
First commissioning	August 2024
Final commissioning complete	February 2025
Wind Farm	
Commencement of Wind Farm construction	June 2023
Mobilisation of plant, delivery of materials to onshore laydown areas (where required)	To match installation timings as set out below.
Timing and sequencing of construction works	Scour protection installation: <ul style="list-style-type: none"> <li>June 2023 – September 2023</li> </ul> Monopile foundation installation: <ul style="list-style-type: none"> <li>October 2023 – May 2024</li> </ul> WTG Transition Piece installation: <ul style="list-style-type: none"> <li>December 2023 – June 2024</li> </ul> Wind turbine pre-assembly: <ul style="list-style-type: none"> <li>January 2024 – October 2024</li> </ul> Wind turbine Installation: <ul style="list-style-type: none"> <li>April 2024 – December 2024</li> </ul> Pre-lay grapnel run (PLGR): <ul style="list-style-type: none"> <li>August 2023– March 2024</li> </ul> Inter-array cable installation:

# Moray Offshore Windfarm (West) Limited Construction Programme and Construction Method Statement



8460005-DBHA03-MWW-PLN-000001

Table 3 Key Milestones Dates	
	<ul style="list-style-type: none"> <li>February 2024 - June 2024</li> </ul> OSP inter-connector cable installation: <ul style="list-style-type: none"> <li>March 2024</li> </ul> Commissioning: <ul style="list-style-type: none"> <li>August 2024 – February 2025</li> </ul>
OfTI	
Commencement of OfTI construction	December 2022
Mobilisation of plant, delivery of materials to onshore laydown areas (where required)	To match installation timings as set out below.
Timing and sequencing of construction works	Horizontal directional drilling (HDD): <ul style="list-style-type: none"> <li>December 2022 – April 2023</li> </ul> Offshore substation platform (OSP) monopile foundation and transition piece installation: <ul style="list-style-type: none"> <li>October 2023 - December 2023</li> </ul> OSP topsides installation: <ul style="list-style-type: none"> <li>October 2023 – December 2023</li> </ul> PLGR: <ul style="list-style-type: none"> <li>January 2023 – July 2023</li> </ul> Offshore export cables (OEC) installation: <ul style="list-style-type: none"> <li>Campaign 1: September 2023 - January 2024</li> <li>Campaign 2: October 2023 – January 2024</li> </ul>



# Moray Offshore Windfarm (West) Limited Construction Programme and Construction Method Statement



8460005-DBHA03-MWW-PLN-000001

## 2.2 Wind Farm Site Construction Programme

The Moray West Wind Farm ('the Wind Farm') construction programme is presented in Figure 2-1 above. With reference to Figure 2-1, and in line with the requirements of the S36 Consent and Wind Farm Marine Licence conditions, the sections below provide details on the following:

- date of the commencement of construction of the Wind Farm;
- timing for the mobilisation of plant and delivery of materials, including details of onshore lay-down areas (where required);
- timing and sequencing of construction works for all elements of the Wind Farm infrastructure;
- contingency planning for poor weather or other unforeseen delays; and
- schedule date for the final commissioning of the Wind Farm.

### 2.2.1 Commencement of Wind Farm Site Construction

The S36 Consent defines the commencement of the construction of the Wind Farm Site as:

*'The date on which the first construction activity occurs in accordance with the EIA Report submitted by the Company on 5 July 2018'*

The Wind Farm Site construction commences with the WTG monopile foundation scour protection installation; this is currently scheduled to commence in June 2023. Therefore, the defined commencement of the construction of the Wind Farm Site is in June 2023.

The delivery and stockpiling of materials and the onshore fabrication activities to facilitate construction of the Wind Farm will commence at a suitable date prior to commencement of Wind Farm construction.

### 2.2.2 Mobilisation of Plant and Delivery of Materials

The key components of the Wind Farm are:

- WTGs monopile foundations;
- WTGs transition pieces;
- WTGs;
- inter-array cabling; and
- OSP inter-connector cable.

Delivery of the Wind Farm components will either be directly delivered to the Wind Farm Site from the location of fabrication, or they will be delivered to an Intermediate Delivery Port (IDP) from the manufacturing facilities for storage in onshore laydown areas and pre-assembly.

The arrival of the plant required to install the Wind Farm components will be timed to coincide with the timing of the main installation activities, as set out in section 2.2.3 below.

#### 2.2.2.1 Monopile Foundations

The monopile foundations will be transported from the fabrication yards to the IDP where they will be stored in an onshore laydown area prior to loadout and delivery to the Wind Farm Site from the IDP.

#### **2.2.2.2 Transition Pieces**

The transition pieces will be transported from the fabrication yards to the IDP where they will be stored in an onshore laydown area prior to loadout and delivery to the Moray West Site from the IDP.

#### **2.2.2.3 Wind Turbine Generators**

The WTG components will be delivered to the IDP where they will be stored at an onshore laydown area for pre-assembly prior to load-out for installation.

WTG components are anticipated to be transported to IDP from the manufacturing facilities for pre-assembly between January and October 2024.

#### **2.2.2.4 Inter-Array Cables**

Delivery of the cables will be phased to match installation requirements. The cables are expected to be loaded onto the cable lay vessel (CLV) at the manufacturing facility and transported directly to the Moray West Site but may be held in interim storage at a quayside.

Where required, cable protection material will likely be mobilised onto the CLV at the point of cable load out and transported directly to the Moray West Site.

#### **2.2.2.5 OSP Inter-connector Cable**

Delivery of the OSP inter-connector cable will be phased to match installation requirements. The cables are expected to be transported directly to Moray West Site from the manufacturing facility.

### **2.2.3 Timing and Sequencing of Construction Works**

This section details the proposed timings and sequencing of construction for all components of the Wind Farm Site and relate it to the construction programme provided in Figure 2-4.

Monopile foundation installation is planned to commence in October 2023 and the programme extends into May 2024 to allow for contingency. The installation of transition pieces is anticipated to commence in December 2023 and to be completed in June 2024.

It is expected that all monopile foundations will have been installed prior to the WTG installation campaign. WTG installation is scheduled to be completed over an approximately 8-month period between April and December 2024. It is likely that WTG installation will proceed at a rate of approximately 2.3 WTGs per week.

Inter-array cable (IAC) installation will take place in a single campaign, anticipated to take place between February and June 2024. During this time, IACs will be laid, buried and terminated at WTG and OSP locations. The IAC installation campaign will also include the installation of the OSP inter-connector cable between the two OSP locations.

### **2.2.4 Final Commissioning of the Wind Farm**

Annex 2 of the S36 Consent defines Final Commissioning as:



# Moray Offshore Windfarm (West) Limited

## Construction Programme and Construction Method Statement



8460005-DBHA03-MWW-PLN-000001

*'The date on which the last wind turbine generator constructed forming the Development has supplied electricity on a commercial basis to the National Grid, or such earlier date as the Scottish Ministers deem the Development to be complete'*

It is anticipated that the Wind Farm will be commissioned over a 7-month period, scheduled for August 2024 – February 2025. As each WTG is fully commissioned it will commence operating and will supply electricity to the National Grid.

The anticipated date of Final Commissioning of the Wind Farm is scheduled to be February 2025, however there is the potential for snagging works to continue beyond this date. As described in Section 2.1, any changes to the dates presented in this CoP will be notified to MD-LOT and incorporated into future revisions of this CoP as required.

### **2.3 Offshore Transmission Infrastructure Construction Programme**

The Moray West OfTI construction programme is presented in Figure 2-1. With reference to Figure 2-1, and in line with the requirements of OfTI Marine Licence condition, the sections below provide details on the following:

- date of the commencement of construction of the OfTI;
- timing for the mobilization of plant and delivery of materials, including details of onshore lay-down areas (if required);
- timing and sequencing of construction works for all elements of the OfTI;
- contingency planning for poor weather or other unforeseen delays; and
- schedule date for the final commissioning of the OfTI.

#### **2.3.1 Commencement of OfTI Construction**

The OfTI Marine Licence defines the commencement of the OfTI construction works as:

*'the date on which the first vessel arrives on Site to begin carrying on any Licensed Activities in connection with the construction of the Works [OfTI]'*

OfTI construction will commence with the start of the HDD at landfall, which is planned to take place in December 2022. Therefore, the commencement of OfTI construction is December 2022.

#### **2.3.2 Mobilisation of Plant and Delivery of Materials**

The Key components of the OfTI are:

- two OSP monopile foundations;
- two OSP transition pieces;
- two cable decks;
- two OSP topsides; and
- two offshore export cable circuits, and cable protection material (if required).

The arrival of the plant required to install the OfTI components will be timed to coincide with the timing of installation activities.

All main elements of the OfTI, other than the OSP monopile foundations and OSP transition pieces (which are expected to be delivered to an IDP in the same manner as the WTG monopiles and transition pieces described in Sections 2.2.2.1 and 2.2.2.2), will be delivered directly to the Development site from the location of fabrication, as required. The OSP topsides will be delivered directly to the Moray West Site or will be transported to the IDP (and stored alongside on the transport barge) until suitable conditions for installation. Some minor ancillary components may be delivered to local ports prior to being transported to the Development site.

#### **2.3.2.1 OSPs Monopile Foundations**

The OSP monopile foundations will be fabricated and delivered during the same time period as the WTG monopile foundations.

#### **2.3.2.2 OSP Transition Piece**

The OSP transition pieces will be fabricated and delivered during the same time period as the WTG transition pieces.

#### **2.3.2.3 OSPs Topside**

The OSP topsides will be transported from the fabrication yard to the IDP, or Moray West Site should operations weather conditions allow, between August to October 2023 in order to meet the installation programme.

#### **2.3.2.4 Offshore Export Cables**

Delivery of the OEC will be phased to match installation requirements. The cables will be transported to the Development site directly from the manufacturing facility.

Where required cable protection material will be transported directly to site from the manufacturing facilities.

### **2.3.3 Timing and Sequencing of Construction Works**

This section details the proposed timings and sequencing of construction for all components of the OfTI and relate to the construction programme provided in Figure 2-1.

At landfall, where the OECs are brought ashore and connected to the onshore export cable, the OEC circuits will be installed using HDD. HDD works and installation of the HDD ducts is anticipated to commence in December 2022 and will be completed by April 2023.

The monopile foundations for the OSP will be installed during the monopile installation campaign as referenced in section 2.2.3 and will take place between October and December 2023. The transition pieces for the OSP will be installed following on monopile foundations installation, between October – December 2023.

# Moray Offshore Windfarm (West) Limited Construction Programme and Construction Method Statement



8460005-DBHA03-MWW-PLN-000001

The two OSP topsides installation is anticipated to take place between October and December 2023 following on from the installation of the OSP foundations.

The two OECs will be installed in two separate campaigns, anticipated to take place between September 2023 and January 2024.

## **2.3.4 Final Commissioning of the OfTI**

The OfTI Marine Licence defines Completion of the OfTI Works as:

*'the date on which Works have been installed in full, or the Works have been deemed complete by the Licensing Authority, whichever occurs first'*

All OECs are scheduled to be installed by January 2024, and the first generation of power is planned for May 2024.

The proposed date for the completion of the OfTI Works is December 2024, which coincides with the final commissioning of the Wind Farm, as this is the date that electricity will be exported from all WTGs. There is the potential for snagging works to continue beyond this date. As described in Section 2.1, any changes to the dates presented in this CoP will be notified to MD-LOT and incorporated into future revisions of this CoP as required.

## **2.4 Contingency Planning**

Given the nature and scale of the offshore construction activities the potential exists for unforeseen delays, including from periods of unsuitable weather and equipment failure which are out of Moray West's control.

Moray West has undertaken weather analysis and assessed programme risks based on offshore construction experience. The Moray West key construction dates set out in this CoP have been designed with reasonable contingency included.

### 3 Construction Roles and Responsibilities

This section sets out the roles and responsibilities of all relevant personnel involved in the construction and installation process of the Development, in relation to the delivery of this CoP and CMS. All Moray West personnel have a responsibility to comply with the requirements of the CMS; however, Figure 3-1 shows the key roles and linkages between the different roles and teams with respect to delivery of the Development. Table 4 details the roles and responsibilities with respect to delivering this CMS.

The chain of command on site comes from Moray West personnel and down through the contractors to any sub-contractors onboard. Masters remain in command of their own vessels but will be directed by Moray West where appropriate. The hierarchy of compliance cascades from Moray West down through the contracting/sub-contracting organisations. Each is responsible for verifying the level of compliance of the one below in the hierarchy.

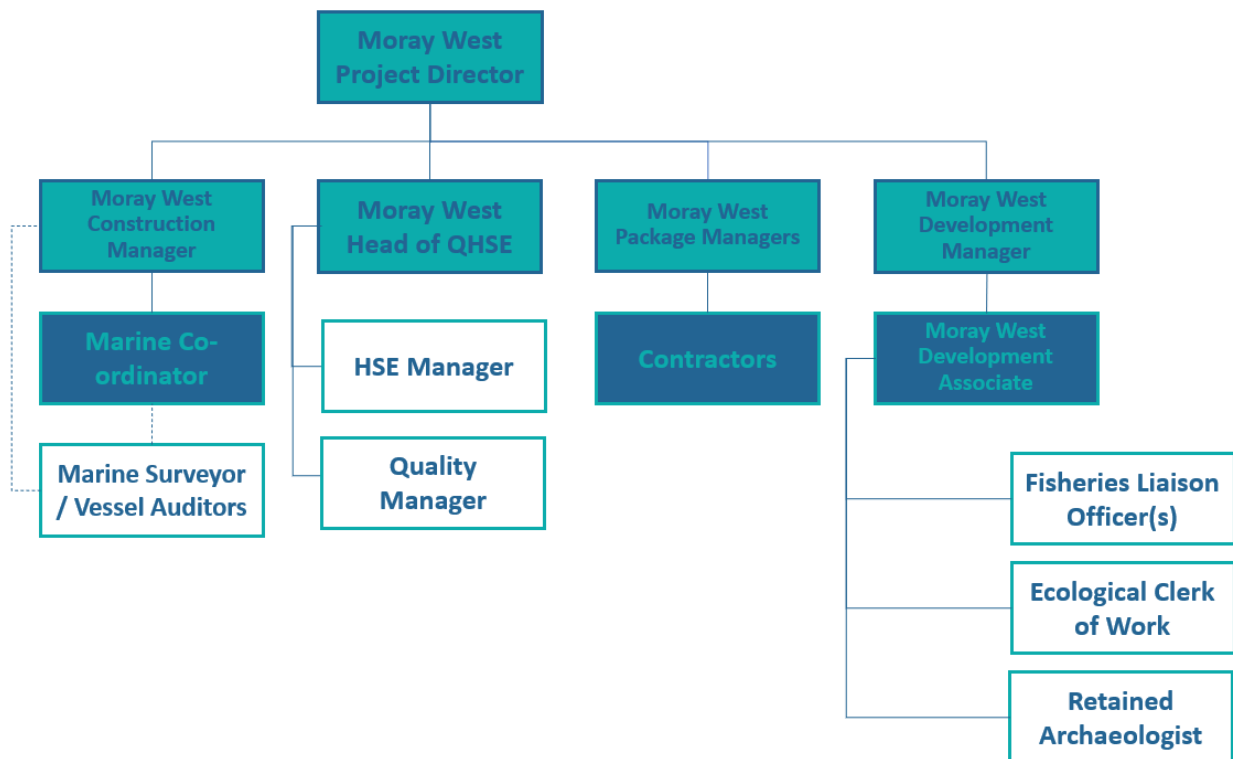

Figure 3-1: Organogram showing the roles and responsibilities of the Moray West personnel, and interface with contractors and other parties involved in the construction and installation process.

**Moray Offshore Windfarm (West) Limited**  
**Construction Programme and Construction Method**  
**Statement**



8460005-DBHA03-MWW-PLN-000001

Table 4 Key responsibilities of personnel relevant to this CoP and CMS	
<b>Moray West Project Director</b>	
Responsibilities:	The Moray West Project Director has overall responsibility for requiring that the Moray West Development is constructed in accordance with the CoP and CMS and associated consent plans. The Moray West Project Director has overall responsibility for the Development’s delivery and governance.
<b>Moray West Head of QHSE</b>	
Responsibilities:	<p>The Moray West Head of QHSE reports to the Project Director. Their responsibilities include the following:</p> <ul style="list-style-type: none"> <li>• Day-to-day contact with contractors.</li> <li>• Collation of performance data.</li> <li>• Inspection and audit.</li> <li>• Incident investigation.</li> <li>• Moray East focal point for deposits, chemicals, transport, waste, and equipment.</li> <li>• Emergency response Liaison with the Moray West Marine Coordinator.</li> </ul>
<b>Moray West Health, Safety &amp; Environment (HSE) Manager</b>	
Responsibilities:	The Moray West HSE Manager reports to the Head of QHSE and is responsible for providing support, advice and guidance on all aspects of HSE management on the Development.
<b>Moray West Quality Manager</b>	
Responsibilities:	The Moray West Quality Manager reports to the Head of QHSE and is responsible for providing support, advice and guidance on all aspects of quality management on the Development.
<b>Moray West Construction Manager</b>	
Responsibilities:	The Moray West Construction Manager will oversee the management of construction activities of the whole Development ensuring that the package managers have the necessary resources to implement environmental management measures detailed within this CMS.
<b>Moray West Package Managers</b>	
Responsibilities:	The role of the Moray West Package Managers is to oversee the delivery of discreet construction work packages and to establish contractual obligations for contractors (and their sub-contractors) in relation to the CMS, and to requiring compliance with these contracts.

**Moray Offshore Windfarm (West) Limited**  
**Construction Programme and Construction Method**  
**Statement**



8460005-DBHA03-MWW-PLN-000001

<b>Moray West Development Manager</b>	
Responsibilities:	Ensuring ongoing consent compliance of the Development is ultimately the responsibility of the Moray West Development Manager, supported by the Development Associate and the ECoW.
<b>Moray West Development Associate</b>	
Responsibilities:	Ensuring ongoing compliance with the CoP and CMS is ultimately the responsibility of the Moray West Development Associate, supported by the ECoW. The Moray West Development Associate will be responsible for all other reporting, returns and notifications to MD-LOT and relevant stakeholders as required by the Development consents.
<b>Moray West Environmental Advisor</b>	
Responsibilities:	The Environmental Advisor will support the HSE Manager with undertaking the day-to-day contact with contractors with matters relating to environmental management, collation of performance data, incident investigations, managing inspections and audits, and emergency response liaison with the MC. They are also the main focal point for deposits, chemicals, transport, waste, and equipment.
<b>Marine Coordinator</b>	
Responsibilities:	The Marine Coordinator is responsible for the monitoring of people, vessels, and offshore structures with regards to the safe preparation and execution of offshore construction activities.
<b>Moray West Environmental Clerk of Works (ECoW)</b>	
Responsibilities:	<p>The ECoW is a role required by the marine licences and they work in conjunction with the Moray West Development Manager and Associates. Responsibilities of the ECoW in relation to the CoP and CMS include:</p> <ul style="list-style-type: none"> <li>• quality assurance of this CMS;</li> <li>• providing advice to Moray West on compliance with the CMS;</li> <li>• monitoring compliance with the CMS and associated consent plans;</li> <li>• reporting on compliance with the CMS to Moray West and to MD-LOT;</li> <li>• ensuring appropriate training is provided in relation to construction-related environmental measures and consent compliance; and</li> <li>• ensuring delivery of toolbox talks as appropriate.</li> </ul>
<b>Fisheries Liaison Officer (FLO)</b>	
Responsibilities:	Responsible for establishing and maintaining effective communications between Moray West, contractors, fishermen and other users of the sea during the construction phase. The Company FLO will provide information relating to the safe operation of fishing in the vicinity of the Development during construction.

# Moray Offshore Windfarm (West) Limited Construction Programme and Construction Method Statement



8460005-DBHA03-MWW-PLN-000001

<b>Moray West Retained Archaeologist</b>	
Responsibilities:	<p>The Retained Archaeologist will be responsible for advising Moray West on all archaeological matters relating to the Development that might impact upon archaeological and cultural heritage resources. The Retained Archaeologist has the following responsibilities:</p> <ul style="list-style-type: none"> <li>• Assume clear role of interface between Moray West and Historic Environment Scotland in the event of a potential find or an infringement of an Archaeological Exclusion Zone (AEZ), as detailed in the Offshore Written Scheme of Investigation and Protocol for Archaeological Discoveries (WSI &amp; PAD).</li> <li>• Liaise with Moray West’s ECoW in the event of a potential find or an infringement of an AEZ.</li> <li>• Liaise with Moray West’s ECoW regarding compliance with the WSI &amp; PAD.</li> <li>• Develop and deliver training on relevant aspects of the WSI &amp; PAD to Moray West personnel including input to inductions, presentations, and production of awareness materials.</li> </ul>
<b>Marine Warranty Surveyor / Vessel Auditors</b>	
Responsibilities:	Assessment of vessel biosecurity arrangements and ensures vessels meet the standards required and are appropriate for the purpose of their prescribed roles.
<b>Contractors</b>	
Responsibilities:	<p>All contractors shall ensure that their own procedures encompass and fully discharge the mitigation and management measures and commitments presented in this CoP and CMS. This CoP and CMS forms the framework and the minimum standards for all construction personnel and contractors to comply with. Adherence to the Moray West CoP and CMS will be a contractual requirement.</p> <p>All contractors will liaise with the Moray West ECoW and FLO, including securing compliance with halt notices or amendments to the CMS where approved by the Moray West Project Director.</p>

### 3.1 Key Contractors

Moray West is in the process of appointing key Contractors for the construction of the main components outlined within this CoP and CMS. The key responsibilities and scope of work of each key Contractor are set out below in Table 5. Once all the Contractors have been appointed, table 3-2 will be updated.

The key Contractors will be responsible for identifying and contracting subcontractors such as may be required to provide services for the completion of the construction works.

# Moray Offshore Windfarm (West) Limited Construction Programme and Construction Method Statement



8460005-DBHA03-MWW-PLN-000001

Table 5 Key Contractor roles and responsibilities / scope of work	
Scope of Works	Key Contractor(s)
Supply, transport, and installation of WTGs	Siemens Gamesa Renewable Energy
Supply, transport, and installation of inter-array cables	Seaway7
Supply, transport, and installation of offshore export cables	Nexans Norway AS
Supply and installation of foundations	Boskalis and DEME
Supply and installation of OSP topsides	Boskalis

Moray West will collate key personnel contact details into a Project Contact Register. This will be provided to MD-LOT separately once available and prior to Construction.



## 4 Construction Methods and Procedures

### 4.1 Introduction

This section presents the construction methods and procedures for each pre-construction (seabed preparation) and construction component of the Development. The main pre-construction and construction components are as follows:

- Pre-construction seabed preparation
  - Unexploded ordnance (UXO) removal
  - Boulder clearance
- Scour protection installation
- Monopile foundations installation – WTG and OSP
- OSP topsides
- Inter-array cabling and OSP inter-connector installation
- WTG installation
- Offshore export cable installation
- Electrical infrastructure commissioning

Good working practices to be applied during construction are described separately under Section 5.

### 4.2 Pre-Construction Seabed Preparation

Prior to the commencement of construction of the Development, a series of seabed preparatory works will be carried out to facilitate the successful installation of the construction components, including cabling works and monopile foundations.

#### 4.2.1 Unexploded Ordnance

The requirements for UXO clearance will fall under a separate Marine Licence; however, an overview of the works is provided here for completeness.

A detailed geophysical survey will be carried out in order to identify potential UXO targets on the seabed. The surveys comprise an array of magnetometers and high frequency imaging sonar equipment which are towed over the seabed in order to identify any anomalies that may potentially be UXOs. The survey data will then be analysed by a UXO specialised who will review the potential UXO anomalies that may be a threat to the installation of the Development components, with avoidance being the primary risk mitigation.

Where potential UXO items cannot be avoided, they will be individually inspected by ROV and, if confirmed to be a UXO, measures will be put in place to remove the UXO. These measures involve calculating the charge required to detonate the UXO. UXO removal will be carried out by specialist contractors.

UXO removal operations will be carried out in daylight hours and will comply with all mitigation measures identified within the risk assessment prepared for the European Protected Species (EPS) Licence application, prepared to support the UXO clearance.

#### 4.2.2 Boulder Clearance

In areas where boulders are present that may inhibit cable, foundation or WTG installation, a boulder clearance campaign will be carried out ahead of cable or foundation installation activities. Boulders may be relocated by grab or plough methods where they will be moved onto a patch of seabed adjacent to the cable route, depending on the size and quantity of boulders.

For areas with a large number of boulders, i.e., a boulder field, a towed plough unit might be used to clear the route (see Figure 4-1). The plough is deployed from an anchor handling vessel over a stern roller, towed over the seabed and pushed boulders or debris to either side of the cable route. Following deployment of the boulder plough, a remotely operated vehicle (ROV) will be used to survey the cleared path and identify any remaining boulders. Any remaining boulders will be removed using a grab.

For areas with fewer, or individual boulders, a boulder grab is used instead of a plough (Figure 4-1). The boulder grabbing method involves picking up boulders, one by one or multiple boulders together, and moving them outside of a defined area.

Boulder clearance works will be covered under a separate Marine Licence.



Figure 4-1: Example of a boulder grab system (left) and scar plough (right).

### 4.3 Scour Protection Installation

It is currently envisaged that the first Wind Farm Site construction activity will be the installation of scour protection around the base of the pile, which will be required at all 62 locations (60 WTG and 2 OSP). Scour protection is required to ensure that the seabed remains stable during the operational life of the wind farm. It is possible that local scour can occur round the edge of the monopiles. This could become a structural problem for the monopiles, but especially for the cables as these require a solid foundation at the points where they touch down on the seabed.

A subsea rock installation vessel will install scour protection on the seabed at the base of the foundation. It will transport rock from the quarry direct or from a storage yard to the site, where it will discharge it. This will be done either using a vertical or inclined fall pipe.



Figure 4-2: An example of a typical subsea rock installation vessel

The scour protection may be installed either prior to or after the monopile installation, between June and September 2023, as described in Table 2-1. Figure 4-2 shows a typical subsea rock installation vessel.

### 4.4 Foundation Installation

#### 4.4.1 Components to be Installed

The main components to be installed are summarised in Table 6. The WTG and OSP foundations are shown in Figure 4-3 and Figure 4-4.

# Moray Offshore Windfarm (West) Limited Construction Programme and Construction Method Statement

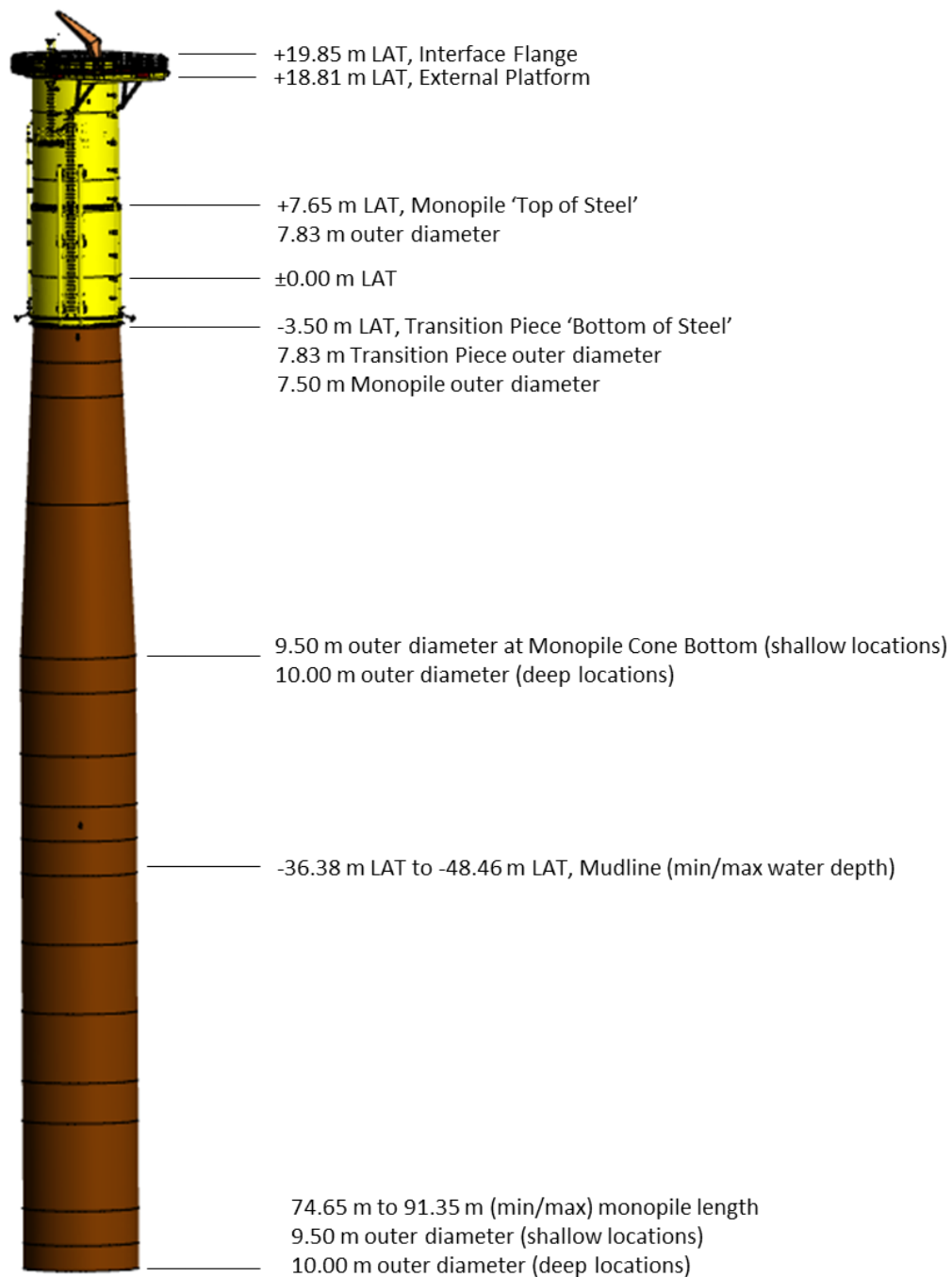

Figure 4-3: Example of the WTG and OSP foundation and transition piece.

Moray Offshore Windfarm (West) Limited  
 Construction Programme and Construction Method  
 Statement

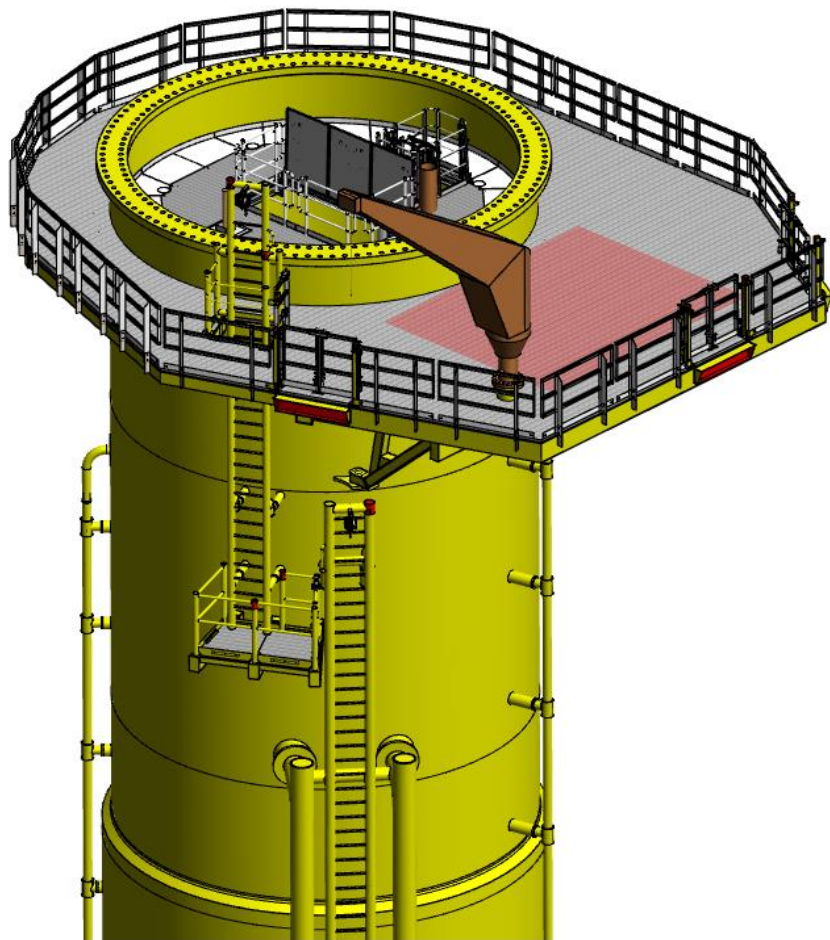

Figure 4-4: Drawing of WTG and OSP transition piece.

Table 6 Summary of WTG and OSP foundation and support components to be installed		
Component	Number	Key Dimensions
WTG monopile foundation	60	Pile diameter: up to 10 m Pile Length: up to 90 m
WTG transition piece	60	TP diameter: up to 8 m TP Length: up to 24 m
OSP monopile foundation	2	Pile diameter: up to 9.5 m Pile Length: up to 86 m

Table 6 Summary of WTG and OSP foundation and support components to be installed		
Component	Number	Key Dimensions
OSP J-tube cage	2	Overall cage height: ~38m Outer diameter cage: Ø11m Outer diameter bottom J-tube exit: Ø12.6m
OSP transition piece	2	Overall OSP TP Height: ~27m. Outer diameter: Ø7.8m

#### 4.4.2 Delivery to the Development Site

The various components that make up the foundations and support structures shall be delivered from their port of origin to the selected IDP ready to be shipped out to the Moray West Site as required.

The contractor will load up the components at the IDP using a suitable vessel, which will either be a jack-up vessel (JUV) or a heavy lift vessel (HLV; Figure 4-5).



Figure 4-5: Example of a HLV, the 'Orion', which may be used to transport the monopiles from the IDP to the Moray West Site. Such a vessel will be able to install six monopiles per trip.

#### 4.4.3 Methods and Process of Installation

The sequence of events and indicative durations for the installation of foundation and supporting components are illustrated in Figure 4-6 and Figure 4-7.

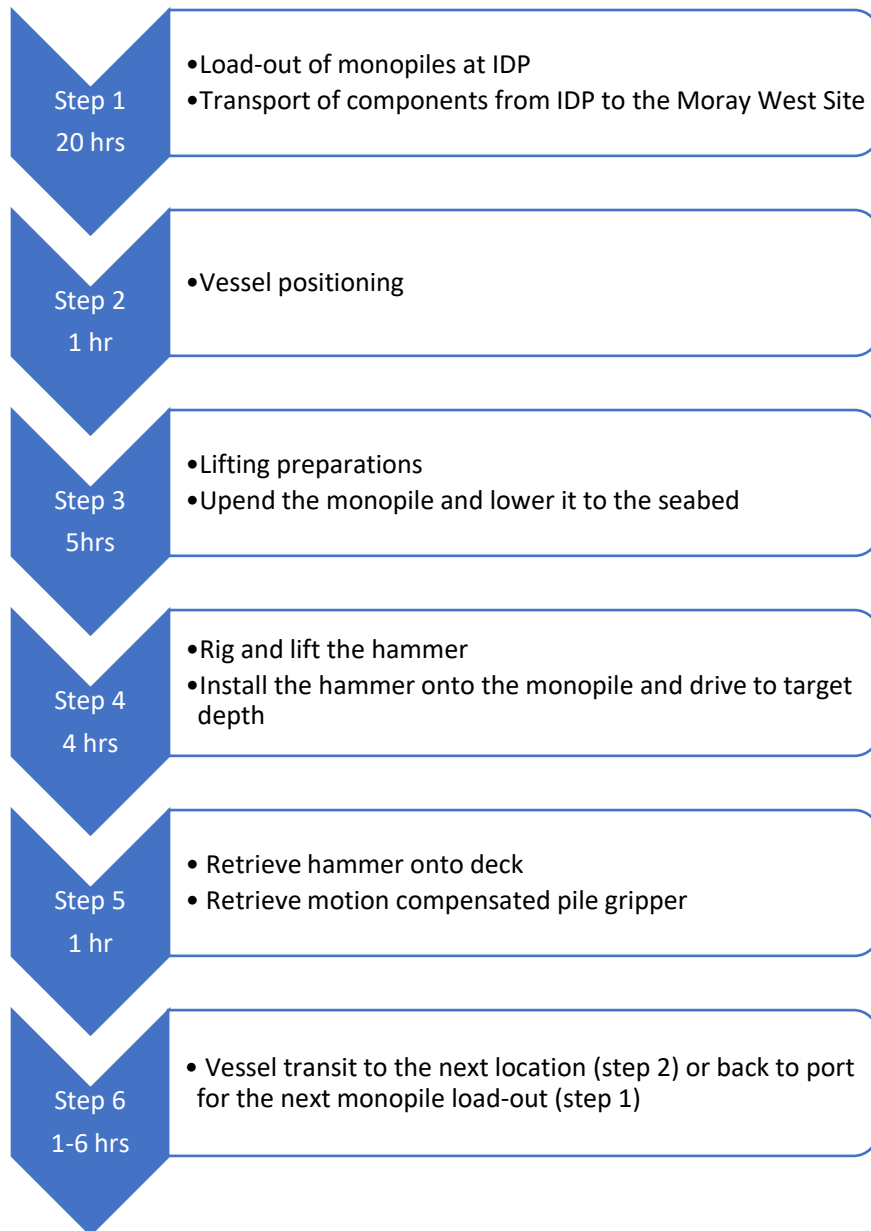

Figure 4-6: Overview of the WTG and OSP piled foundation transport and installation

# Moray Offshore Windfarm (West) Limited Construction Programme and Construction Method Statement

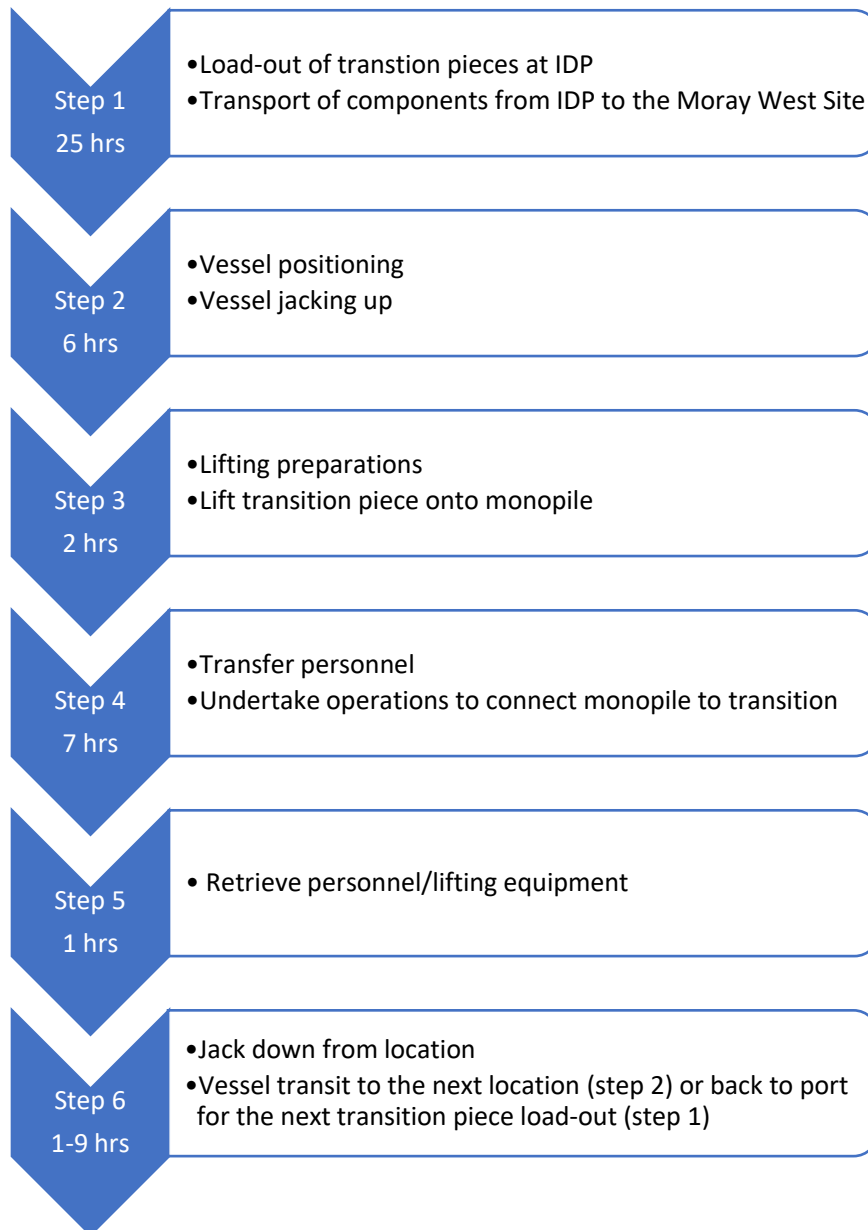

Figure 4-7 - Overview of the WTG and OSP transition piece transport and installation



#### 4.4.3.1 Pile Installation Works

Once the vessel has reached the target location, the vessel will position itself using dynamic positioning in readiness for the foundation installation works. A visual survey may be carried out to confirm the seabed conditions prior to pile installation.

The monopile will then be upended and lowered to the proposed WTG location by means of a flanged monopile upending tool, designed in such a way so as to prevent the monopile from sliding during the upending process. Once the monopile is vertical, the gripper on the upending tool will be closed and the monopile will be lowered and stabbed onto the seabed. Rollers found in the gripper will guide the monopile, thus allowing for a degree of freedom when lowering to ensure the correct location is targeted.

After the monopile has been positioned vertically on the seabed, the hydraulic hammer is lifted from the vessel deck and onto the top of the monopile. Figure 4-8 shows a typical example of the hydraulic hammer being installed on top of the monopile and the gripper in action.



Figure 4-8: Example of the hammer being installed onto the top of the monopile.

Once the self-penetration and vertical positioning of the monopile are checked, the piling process can begin. The piling process will use a soft-start method for a set amount of time before ramping up to full energy. Full details of the piling methods and associated mitigation can be found in the PS.

Once the pile has been driven to target depth, a final check will be carried out using onboard cameras and survey equipment, and a visual check will be performed from the gripper claws. The final monopile

inclination and elevation will be measured and logged. In addition, a temporary monopile cover with appropriate navigation lights will be fitted onto the monopile (see Figure 4-9 for an example of a monopile cover installation).



Figure 4-9: Example of a monopile cover installation.

Once the monopile installation is complete, the vessel will move to the next location and repeat the above steps for the installation of the next foundation or sail back to port to load the vessel with the next set of monopiles.

#### **4.4.3.2 Transition Piece Installation Works**

Once the vessel has reached the target position, it will jack-up to operational height (if using a JUV) or position on Dynamic Positioning (if using a HLV) and prepare for the installation of the transition piece. The first operation will be to remove the monopile cover and deploy the monopile cleaning tool. This will clean the upper section of the monopile to remove any marine growth that has accumulated since monopile installation. After cleaning is complete, the transition piece will be rigged into the main crane and lifted. It will be slewed outboard and lowered over the monopile – making use of the installation guides provided on the bottom of the transition piece skirt. Once landed, the gangway of the JUV or HLV will be deployed onto the external platform and personnel will enter the transition piece and conduct the bolting operations. As soon as sufficient bolts are installed to ensure the stability of the transition piece, the rigging will be removed. Bolting will continue as grouting operations are started also. Once both have been completed, the transition piece will be removed of all waste materials, personnel will relocate back to the installation vessel and the gangway will be raised. The installation vessel will then move on to the next foundation or sail back to port to load the vessel with the next set of transition pieces.

**4.4.3.3 As Built Survey**

After approximately half the monopile foundations are installed, an intermediate survey will be carried out. A final, as built survey and report will be carried out once all monopile foundations are installed. Such surveys will typically consist of a multibeam echosounder (MBES) and side scan sonar (SSS) surveys.

**4.5 Offshore Substation Platform Topsides**

**4.5.1 Components to be Installed**

The Moray West Development will include two OSPs. The main purpose of an OSP is to house the electrical high voltage equipment for the transformation of power produced by the WTGs for onward export to the onshore substation. Each OSP will consist of a topside module installed onto a monopile foundation. The OSP foundation will include a cable deck and J-tube conduits for the accommodation of the IAC and OEC connections. The main components to be deposited or installed are summarised in Table 7.

Table 7: OSP topside specification		
Component	Description	Key Dimensions
OSP topside	Two OSP topsides	36.4 x 31.01 x 15 m
Grout		8 m <sup>3</sup> of grout per location (16 m <sup>3</sup> grout total)

**4.5.2 Delivery to the Development Site**

The OSP topsides will be delivered to the IDP from the fabrication yard at Wallsend, UK before being delivered to the Moray West Site on a cargo barge. There is also the option to deliver the OSP topsides straight from the fabrication yard to the site, should operations and weather allow.

**4.5.3 Method and Process of Installation**

The OSP installation sequence is presented in Figure 4-10 below. Installation of the OSP topsides will be using the same HLV or JUV used for installing the foundations. The first OSP topside is expected to be installed at the same time as the monopile foundation campaign with the second OSP topside installation approximately one month after.

# Moray Offshore Windfarm (West) Limited Construction Programme and Construction Method Statement

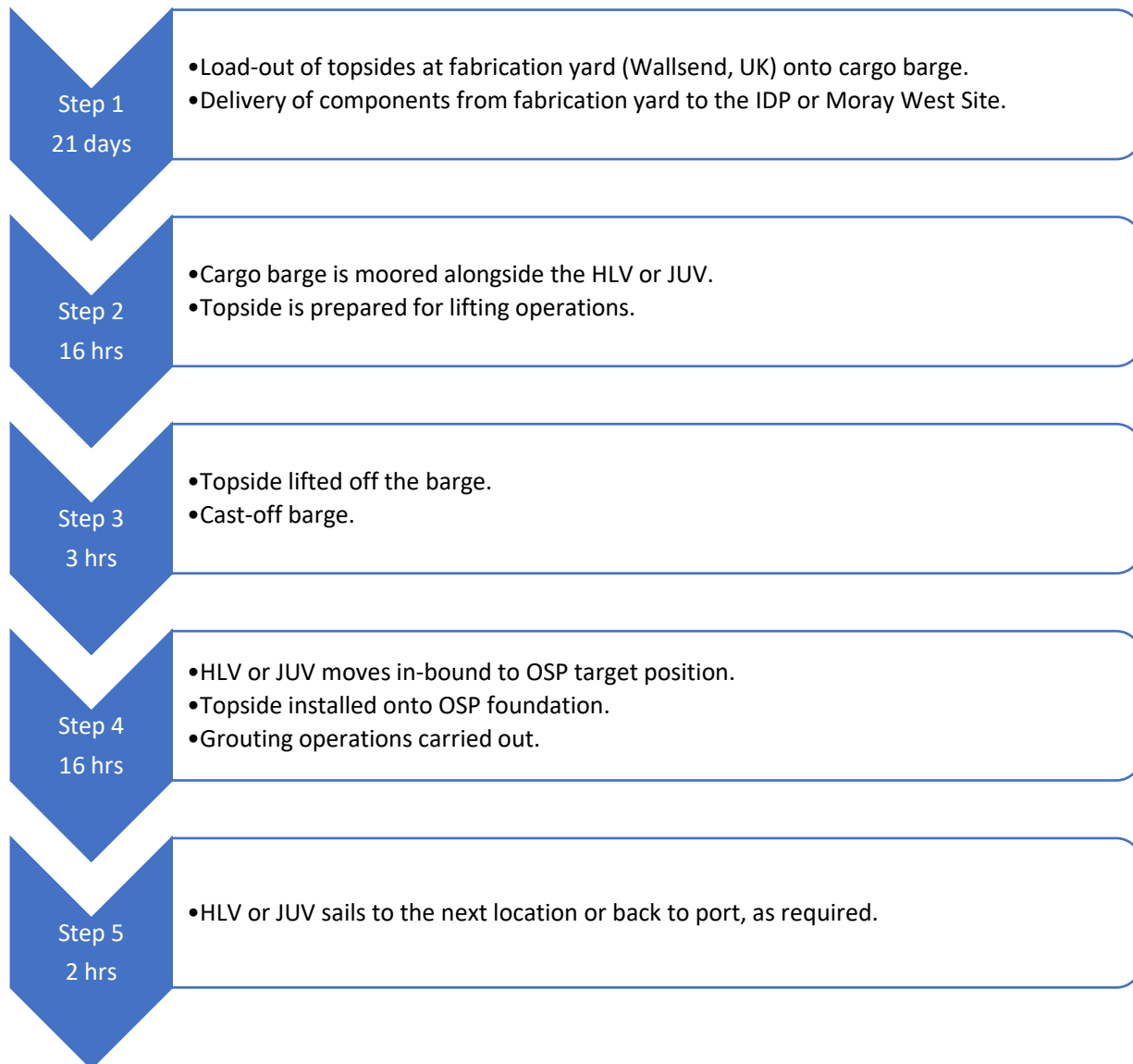

Figure 4-10: Overview of the OSP topside installation

Each OSP topside module, which includes the transformer and associated switchgear, will be assembled as a single unit prior to being loaded onto a cargo barge at the fabrication yard at Wallsend, UK, and transported directly to the IDP or Moray West Site, should operations weather conditions allow. Once on Site, the cargo barge will moor up alongside the HLV or JUV, which will carry out the topside installation.

Once a sufficient weather window is available, the lift will commence using the HLV or JUV and the topside will be lowered onto the monopile foundation transition piece. The topside module will be secured into position by using a grouted connection.

The installation, testing and termination of the OEC onto the OSP is described in Section 4.8.6, and for the inter-array and OPS inter-connector cables in Section 4.6.4.

## 4.6 Inter-Array and OSP Inter-connector Cable Installation

### 4.6.1 Components to be installed

The IAC connect the WTGs in a series of arrays or ‘strings’ and also provide the connection from the WTGs to the OSP. The OSP inter-connector cable connects the two OSPs together. The full cable arrangement is provided in the DSLP.

The main components to be installed are summarised in Table 8 below. Full details of IAC installation can be found in the Wind Farm CaP.

Table 8: Inter-array and OSP inter-connector cable specifications		
Component	Description	Key Dimensions
Inter-array cabling	3 core 66 kV armoured XLPE AC cable with 300 mm <sup>2</sup> or 800 mm <sup>2</sup> cross sectional area (CSA) aluminium conductors	Approximately 150 km in total length.
Inter-connector cable	3 core 66 kV armoured XLPE AC cable with 800 mm <sup>2</sup> CSA aluminium conductor	Approximately 14 km in total length
Cable protection including rock, concrete mattresses, and CPS	Exact volumes and quantities are dependent on cable burial success; therefore, will be determined post cable installation.	As required

A detailed route engineering exercise and burial assessment study will be carried out in order to design the optimal cable routes across the site. The route engineering shall account for the following:

- soils and shallow geology to evaluate burial performance or burial risks;
- seabed topography, mobile features and potential free span;
- maintaining clearance from debris, wrecks, and potential UXOs;
- minimise the level of boulder clearance; and
- installation limitations and cable approaches to structures.

#### **4.6.2 Delivery to the Development Site**

The IAC and OSP inter-connector cables will be loaded onto the CLV at either the port of cable manufacture or transported from the cable manufacturing facility to an interim marshalling port in the UK for load-out to the CLV.

#### **4.6.3 Method and Process of Installation**

The sequence of events and indicative durations for the installation of the inter-array and OSP inter-connector cables are illustrated in Figure 4-111. For the purposes of presenting the process and durations of each key activity, it should be noted that the sequence and durations described are for a typical indicative inter-array cable length between two WTGs. As there are expected to be 60 such cable lengths, plus the OSP interconnector cable, the durations shown are not intended to describe the overall duration of the inter-array and OSP interconnector cables installation works, which is shown in Section 2.

Whilst the activities illustrated in Figure 4-11 are sequential for each cable section, because the cycle is repeated for each cable section, there may be works underway on more than one cable section within the Development site simultaneously (e.g. survey works may be underway on one cable section at the same time as cable lay or pull in works are underway on another cable section). It should also be noted that although the activities illustrated in Figure 4-11 will be completed in the sequence shown, the total duration from the first to the final activity may be longer than the cumulative total of the individual activities, because there will be periods of time between each activity when works are not taking place.

# Moray Offshore Windfarm (West) Limited Construction Programme and Construction Method Statement



Figure 4-111: Overview of the inter-array and OSP inter-connector installation

#### **4.6.3.1 Pre-Installation Survey**

The pre-installation survey will collect geophysical site information using MBES and/or SSS in order to update the route engineering design studies and trenching assessment study. This scope of works is typically undertaken not less than 8 months prior to offshore installation in order to have adequate time to update plans and documentation. The work will be carried out by a dedicated geophysical survey vessel.

#### **4.6.3.2 Pre-Lay Grapnel Run and Boulder Clearance**

A PLGR vessel will be mobilised together with the required survey and positioning equipment, grapnel anchor(s) and towing winch with the required rendering capacities to remove any debris, such as fishing gear, from the cable route.

If required, a boulder clearance campaign will be carried out prior to the installation of the cable where boulders will be picked up using a boulder grab and relocated to outside the cable route. For full details on boulder clearance see Section 4.2.1.

A PLGR will be conducted to remove linear seabed surface debris along all cable routes, i.e., OEC, IAC, and OSP inter-connector cable routes. Surface debris can include items such as fishing gear, wires, and ropes located along the routes. A 'train' of grapnel hooks (see Figure 4-12 and Figure 4-13) will be towed by a standard offshore anchor handling vessel, maintaining a speed of approximately 1-2 knots, along the centreline of each route prior to cable installation procedures. The grapnel assembly is capable of penetrating 0.5 m into the seabed. The position of the PLGR on the seabed will be monitored using ultra-short baseline (USBL) subsea positioning (or similar) to ensure that the grapnel stays within the above defined corridor.

Practical limitations apply with respect to approach to existing and planned structures, crossings and landfall approaches, for example no PLGR is typically allowable within 500 m of an existing structure; therefore, PLGR is preferred to be done prior to the installation of the foundations. Any debris found will be recovered, where safe and practical to do so, and taken on board the vessel before being taken to port and properly disposed of.





Figure 4-12: Example of a typical PLGR train on board the vessel.

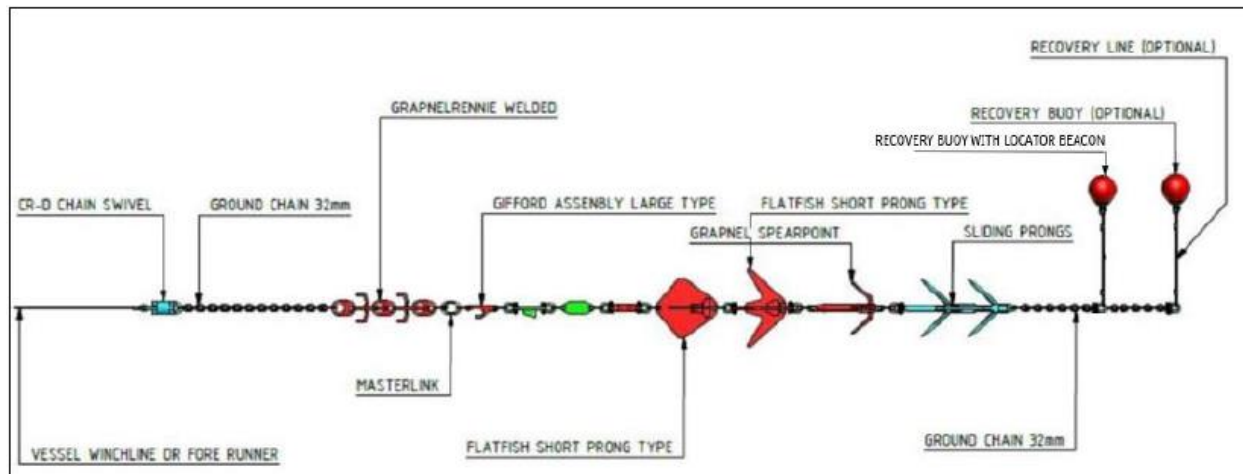

Figure 4-13: Schematic of a typical PLGR chain assembly.

#### 4.6.3.3 Pre-Lay Route Inspection

This inspection will be undertaken by the CLV ROV in order to verify the positions of the foundations including positions of bellmouth and/or entry holes. The extent of the scour protection will be confirmed, and the cable route is visually inspected to confirm it is free from any obvious surface debris just prior to cable installation.

#### **4.6.3.4 Cable Installation**

Cable installation will be undertaken by a single CLV which will have been pre-loaded with the subsea cable lengths and stored on cable carousels. The installation of the inter-array and OSP inter-connector cables will be completed on a string by string basis. The installation support vessel will work ahead of the CLV, and the pull-in teams will set up the pull-in equipment and prepare each structure for cable installation. Each team will be transferred to the asset using the walk-to-work (W2W) system or by crew transfer vessels (CTVs).

Prior to cable pull-in, a dedicated preparations teams will be deployed to carry out the following works:

- Using the offshore crane, the cable pull-in spread is transferred to the external platform of the foundation.
- The assembled Cable Protection System (CPS) will be arranged on the deck of the CLV, and the sealed end of the cable will be pulled from the carousel and through the CPS on the back deck of the CLV.
- The pull-in team will deploy a mini ROV to install the messenger wire through the monopile aperture for the WTG foundations and through the J-tube for the OSPs . It will then be connected to the front of the cable on the CLV.
- The pull-in team will then prepare the winch wire and rigging arrangement for pull-in, ensuring the rigged up lines are inspected for any snags, twists or obstructions. Once this is done, the pull-in team will confirm to the offshore installation manager and vessel captain on the bridge of the CLV that pull-in preparations are complete.

Once the pull-in preparations are complete, the IAC contractor will execute the cable pull-in using either a conventional or traction winch, which will be set-up on the transition piece cover connected to the transition piece bolting flange. After the cable is pulled-in to the correct length a temporary hang-off is installed and the excess of cable removed.

Following the first end pull-in of the cable at the OSP or WTG, the dynamically positioned CLV will commence laying along the planned cable route towards the subsequent WTG pull-in location. Personnel will undertake preparatory works on the WTG or OSP prior to the arrival of the CLV as detailed prior to first end cable pull-in.

A work-class ROV (class of ROV with additional tooling and sensor capabilities) will follow at the touch down point of the cable on the seabed to monitor the lay-down position of cable. The CLV offset will be adjusted to the design route if necessary and the as-laid survey data will be used at a later stage for the post-lay trenching operations.

During cable lay, when the CLV is at a pre-determined distance from the second end pull-in structure, a cable marker shall be placed on the cable. At a determined position, the cable shall be cut and sealed. The CPS for the second end is then fitted to the cable. Simultaneously, using the work-class ROV, the

messenger wire shall be recovered on board the CLV and hauled in until the winch wire has been recovered on board.

The connection between the pull-in wire and the cable end shall be established and pull-in of the cable shall commence, with the work-class ROV monitoring the cable and CPS entering the entry hole of the WTG foundation or J-tube on the OSPs. After the second end of the cable is pulled-in to the structure such that no bight is left on the seabed, a temporary hang-off shall be installed and any excess of cable length not needed for cable routing shall be removed.

#### 4.6.3.4.1 Third-Party Crossings

Six crossings are expected to occur along the proposed IAC routes; two pipelines and four cables. At each third-party crossing, the first step is to install separation layers using mattresses/rock over the cable or pipeline to be crossed. Deposit volumes shall be confirmed following design completion of the crossing. The Moray West cables are then laid over this along with the use of cable abrasion and impact protection along its length. Remedial rock protection is then protected by a protection system/Urduct and covered by a rock berm for completion.

#### 4.6.3.5 Post Lay Trenching

Once cables are installed on the seabed, cable burial will be carried out using a jet-trencher or mechanical trencher as determined by the Cable Burial Risk Assessment (CBRA) Study. Prior to the burial of the cable, a trenching wet trial shall first be undertaken in one location with the proposed trencher over a distance of 200 m parallel to the cable route. This test is to ensure that the trenching tool is fully operational, prior to trenching operations and properly set up for the site conditions. No cable shall be used for the trencher wet trial.

Once the trenching trial is complete and successful, cable burial with the trencher shall proceed. In the case of jet-trenching, the cable is centralised and the jet legs are gradually lowered as the jet trenching tool moves slowly forward and the seabed becomes fluidised beneath the jetting tool. The cable guide is then also lowered and engaged on the cable such that the trenching depth is in accordance with the required trenching specification.

In the case of mechanical trenching, the cable is picked up and loaded into a trough within the tracked trenching tool. The chain cutter is graded down to the design depth of cutting to achieve the required depth of lowering (DoL) of the cable and the cable is laid back down into the cut trench. The depth of lowering is determined by use of the calibrated depressor which positively locates the cable at depth immediately behind the cut trench.

#### 4.6.3.6 Remedial Rock Protection Installation

Following cable burial, a post-trench cable tracker survey of the cables will be completed to determine the depth of lowering. Where the target depth of lowering has not been reached additional cable protection measures may be required which will be limited to the use of rock or concrete mattresses.

#### 4.6.4 Testing and Termination

After the cable protection operations are completed, the overlength of cable pulled into the structure will be stripped back. The three individual cable power cores and the fibre optic bundle are split out. The permanent hang-off assembly is fitted to the J-tube top flange and cable armour wires are secured to the structure to support the cable weight.

The individual cable cores are then routed through the internal foundation/topside structures on the cable management system and terminated with a connector into the electrical switchgear. All accessories and cable elements which require it are electrically earthed to the foundation. After termination, post installation electrical and fibre optical testing will be carried out to verify there are no defects or damage in the cable system. The completed IAC system is then handed over for energisation of the cable network.

Any excess armour wiring and cable fillers shall be taken back on the vessel for appropriate disposal onshore.

### 4.7 Wind Turbine Generator Installation

#### 4.7.1 Components to be Installed

This section covers the loading, transport, pre-assembly, and installation of WTG components. Major components include the tower, which is installed on top of the transition piece, the nacelle, which supports the rotor, and the three individual blades which form the rotor.

WTG installation will follow on from the installation of the piled foundations and will take between April to December 2024. The main WTG components that will be installed are summarised in Table 9.

Table 9: Summary of WTG components to be installed		
Component	Number	Key Dimensions
Wind turbine tower sections	4 sections per WTG	Tower length: 126 m Max diameter : 7.5 m
Wind turbine nacelles (housing the generator, etc.)	60	
Wind turbine blades	180 (3 per WTG)	Length : 108 m Max chord: 6.3 m Root diameter: 4.5 m

#### 4.7.2 Delivery to the Development Site

The various components that make up the WTG shall be delivered from their port of origin to the selected IDP for assembly before being transported to the Moray West Site as required.

# Moray Offshore Windfarm (West) Limited Construction Programme and Construction Method Statement



8460005-DBHA03-MWW-PLN-000001

Table 10: Origin of each WTG Component			
Component	Origin (presumed)	IDP (presumed)	Estimated no. of components per trip to IDP
Wind turbine tower sections	Europe (Denmark and Spain)	TBC (likely to be Port of Nigg)	4 per trip
Wind turbine nacelles (housing the generator, etc.)	Cuxhaven, Germany		2-6 per trip
Wind turbine blades	Hull, UK		3 per trip

### 4.7.3 Method and Process of Installation

An indicative WTG pre-assembly and installation sequence is presented in Figure 4-12 below. Greater detail on each of the stages in the installation process is then provided in the subsequent sections. Installation of the WTG components onto the transition piece substructure will be completed by the installation heavy-lift JUV Pacific Orca, or similar, from Cadeler.

The WTG components will be loaded onto the installation vessel and fastened for transport to the Moray West Site. It is anticipated that a total of two complete WTGs will be loaded on for a single trip from the IDP to the Moray West Site.

# Moray Offshore Windfarm (West) Limited Construction Programme and Construction Method Statement

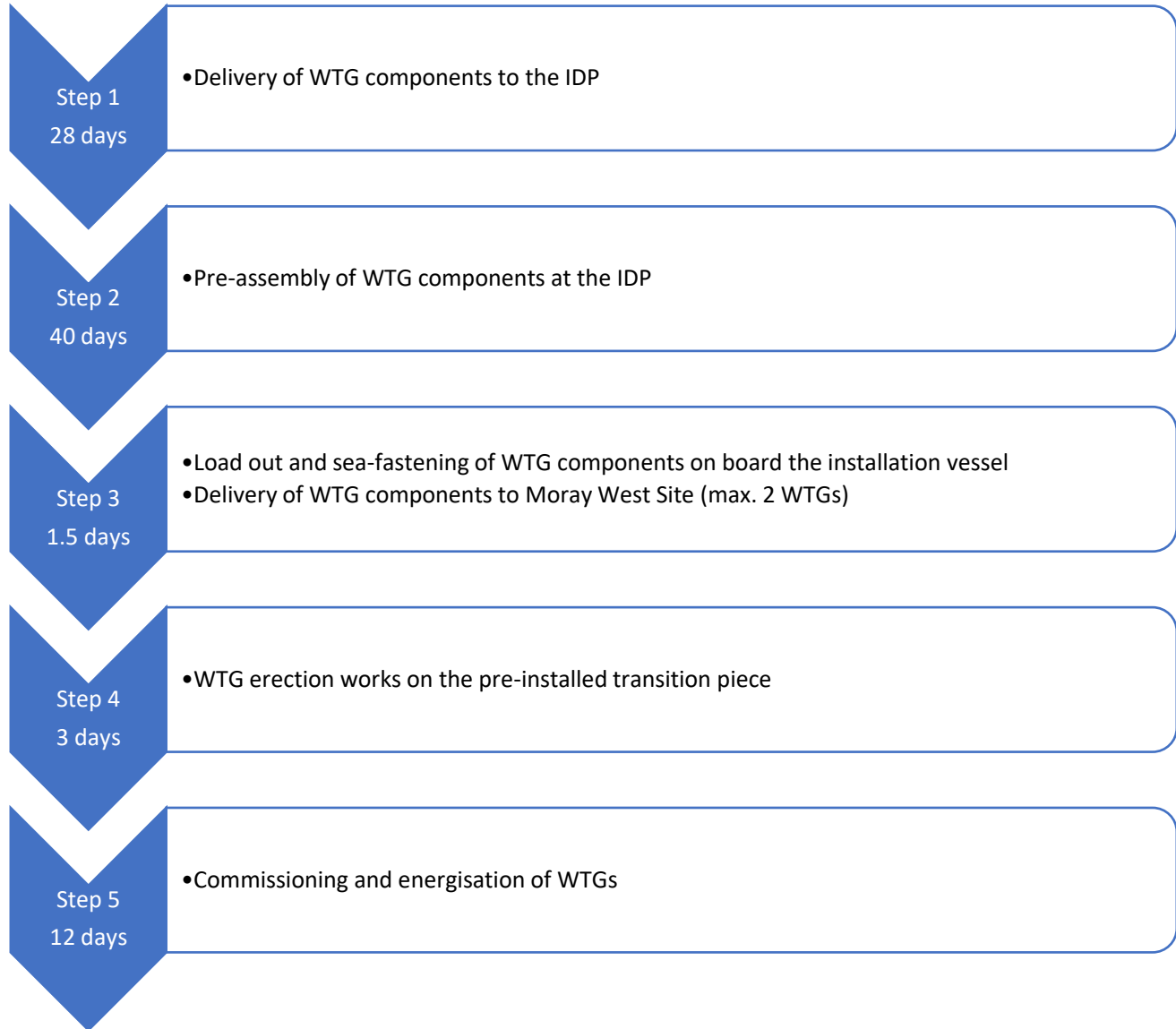

Figure 4-12: Overview of the WTG assembly and installation activities

#### **4.7.3.1 Pre-Assembly Works**

Prior to WTG installation, the IDP will store up to 13 full WTG components to ensure there is sufficient buffer to allow the installation activities to continue with the incoming shipment rate of WTG components. The breakdown of pre-assembly activities at the IDP consist of:

- pre-assembly of the tower sections (four sections in total) into a single tower including position for loadout;
- nacelle – storage and positioning for loadout (nacelle assembly is carried out at the contractor’s production location in Germany); and
- inspection and re-stacking of blades followed by positioning for loadout.

#### **4.7.3.2 WTG Installation**

##### **4.7.3.2.1 Tower Installation**

Once the installation vessel is in position, the installation of the pre-assembled tower will proceed as follows:

- The transition piece cover is removed, and the transition piece is cleaned.
- The full tower is unfastened from the grillage on board the installation vessel and lifted by the vessel’s main crane using the tower gripper.
- The tower gripper is attached to the tower top flange and the full tower is lifted and guided onto the transition piece.
- Once the correct tower position is confirmed, the tower is secured in place.
- The lifting gear is disconnected from the tower and recovered to the installation vessel.

##### **4.7.3.2.2 Nacelle Installation**

The following process will be repeated for each nacelle installation:

- A lifting yoke will be connected to the main crane of the installation vessel and the crane will manoeuvre over the first nacelle to be installed. The nacelle will then be connected to the nacelle lifting yoke through the dedicated lifting points within the main nacelle frame. A tag line system will be used to control the orientation of the nacelle during lifting.
- Sea-fastenings will be released, and the nacelle will be lifted from the installation vessel deck and manoeuvred over the installed tower using the tag line system before being lowered into position.
- The nacelle will be mechanically connected to the tower flange with bolts and fastened according to the contractor’s specifications.

##### **4.7.3.2.3 Blade Installation**

The following process will be repeated for each WTG rotor installation:

- Each blade will be lifted individually using the single blade lifting yoke method (see Figure 4-13). The lifting yoke will be attached to the crane hook and a tag line system will be used to control the orientation of the blade during lifting.

- The hub will be positioned with the blade to be mounted in a horizontal position and the nacelle orientated to allow free access with the blade yoke perpendicular to the boom.
- The blade is then released from its sea fastenings and lifted into position by remote controlling of the yoke. The blade is manoeuvred into position and bolted onto the hub, after which the yoke will be released remotely.
- The blade will be mechanically connected to the hub bearing flange with stud bolts and nuts and then tensioned according to the contractor's specifications.

This procedure is then repeated for the next two blades with the hub being rotated 120 degrees each time so that each blade is mounted from a horizontal position. When all three blades are installed, the blade lifting yoke will be returned to the deck of the installation vessel.

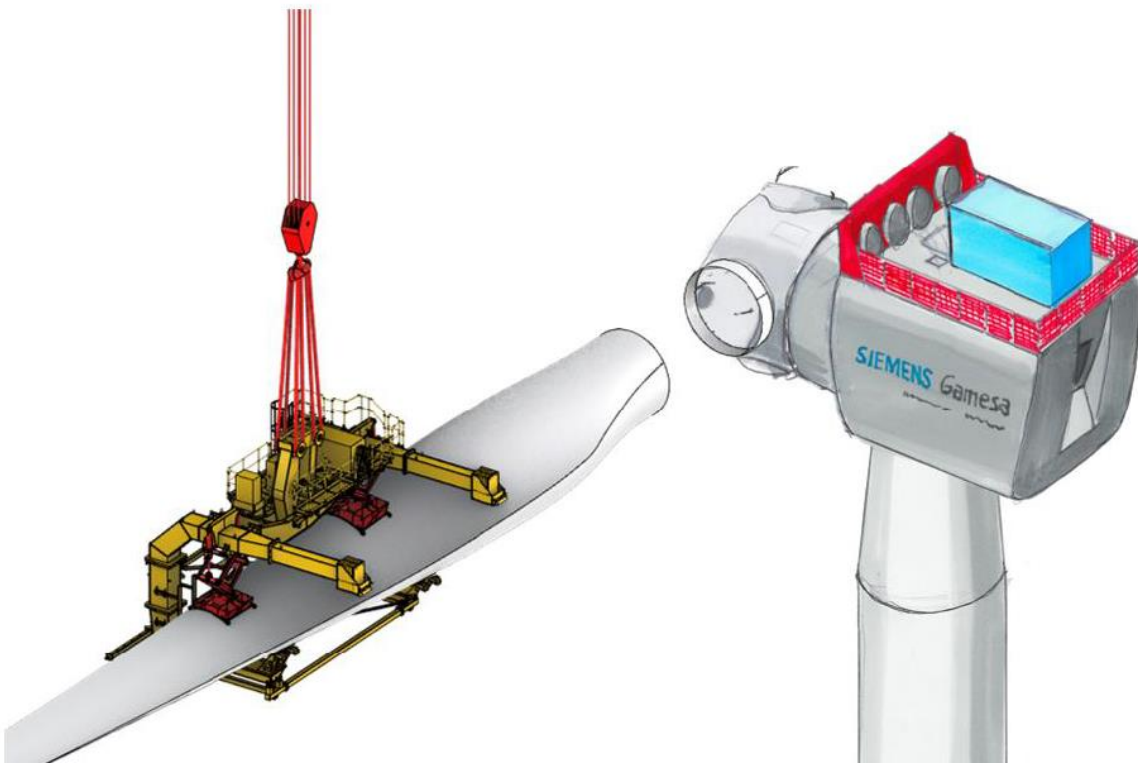

Figure 4-13: Example of the blade lifting yoke method and mounting.

## 4.8 Offshore Export Cable Installation

### 4.8.1 Components to be Installed

This section provides a summary of the main activities of OEC installation. Full details of the OEC installation can be found in the ECP.



The main components that will be deposited or installed are summarised in Table 11.

Table 11 Summary of OfTI components to be installed		
Component	Number	Key Dimensions
HDD ducts	2 HDD ducts	Approx. 500 – 600 m in length Outer diameter approx. 560 mm
Bellmouths, messenger wire and end plugs	Installed on the ends of the HDD ducts in preparation for export cable pull-in	See Figure 4-14 below.
Export cables	2 high voltage alternating current cables (HVAC)	Export cable no. 1 – approx. 50 km Export cable no. 2 – approx. 52 km Outer diameter approx... 255-270 mm
Cable protection including rock, concrete mattresses, and CPS	Exact volumes and quantities are dependent on cable burial success; therefore, will be determined post cable installation.	As required.

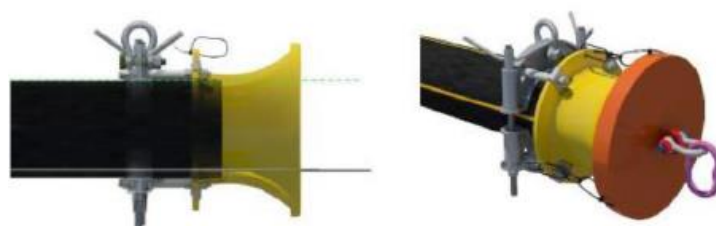

Figure 4-14: Example of a typical bellmouth solution

#### 4.8.2 Delivery to the Development Site

Load-out of the cables onto the CLV will be performed at Nexans factories located either in Charleston, USA or Halden, Norway. Once the cable is loaded, the CLV will transit to the Development. Delivery of the landfall components and equipment e.g., HDD pipes and HDD drilling rig will mostly be delivered by road to the HDD construction site. An access road will be constructed to facilitate access to the landfall site at Broad Craig from the existing local trunk road (A98).

#### 4.8.3 Method and Process of Installation

The sequence of events and indicative durations for the installation of the OEC are illustrated in Figure 4-15.

# Moray Offshore Windfarm (West) Limited Construction Programme and Construction Method Statement

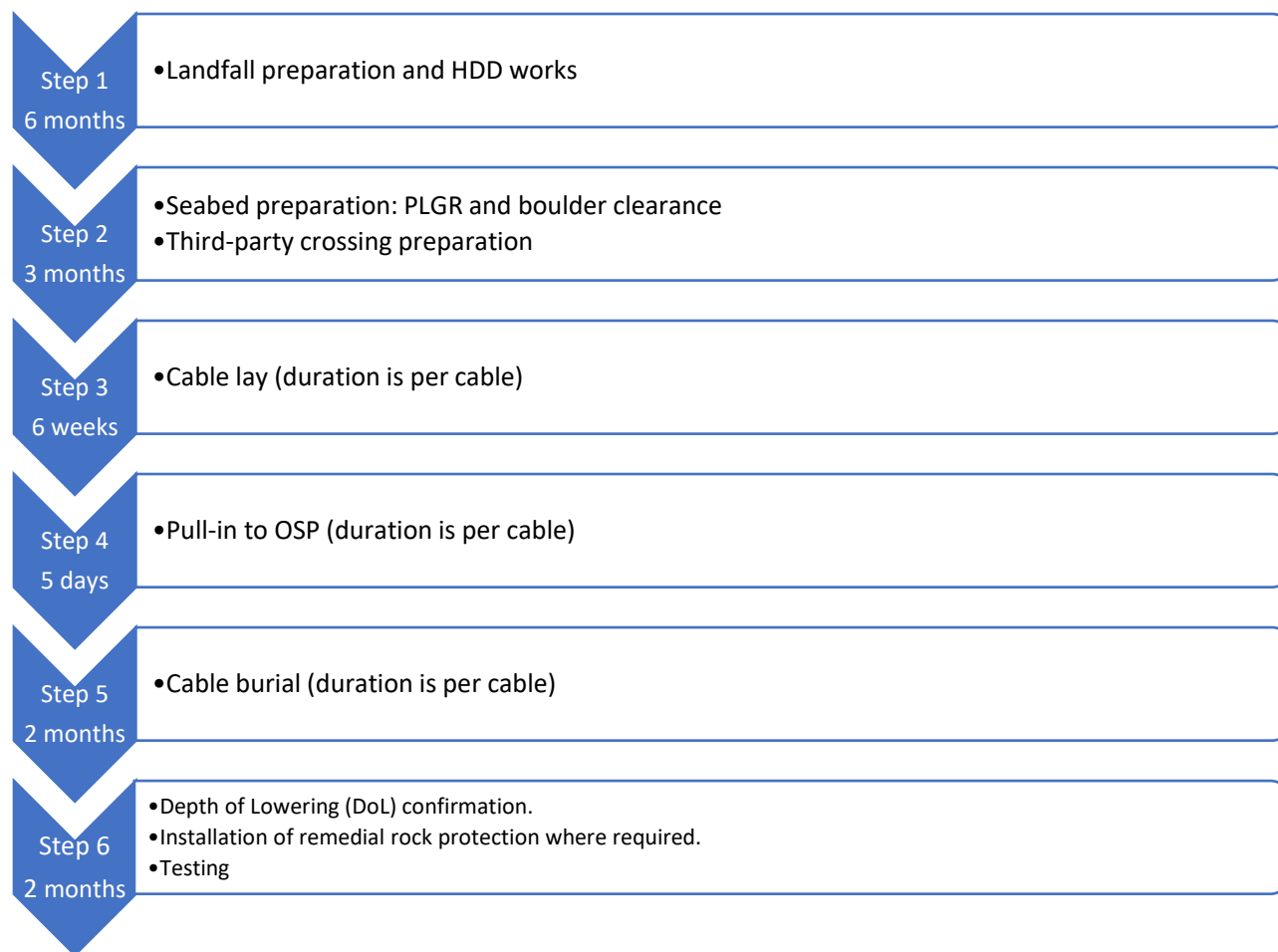

Figure 4-15: Overview of the OEC installation

## 4.8.4 Pre-Installation Preparatory Works

### 4.8.4.1 Landfall Preparation and HDD Works

The ‘landfall’ is the location where the OECs are brought ashore and connected to the onshore export cable within transition joint bays (TJBs). The TJBs comprise buried underground chambers, cofferdams or similar that are installed at a location above mean high water springs (MHWS) to allow the jointing of the onshore and offshore sections of the export cables. HDD works to construct the ducts are expected to take place between December 2022 and April 2023 with further preparation works performed ahead of the OEC pull-ins.

Two HDD ducts shall be established at the landfall location at Broad Craig, located approximately between Portsoy and Red Haven Cliff on the Aberdeenshire coast. The HDDs and ducts will be approximately 600 m in length and installed one at a time. The HDD exit location is expected to extend offshore by

approximately 400 m. The HDD involves drilling a bore underground between two points, into which ducting for the OEC can be installed. To achieve this, an onshore drill rig will commence drilling at the onshore end of the construction at the Broad Craig. This method seeks to ensure that there is minimal disruption to the cliff area, under which the HDD ducts will be installed, and the export cables routed.

The HDD works will be undertaken in such a way as to cause minimum disruption to local communities. The working area will be fenced off and access through the works will be restricted for health and safety reasons.

The HDD process will comprise the following stages:

1. A small diameter pilot hole will be drilled from the onshore drill site, for the purpose of defining the path of the channel into which the ducts and later the cable is to be installed.
2. The pilot hole will be enlarged using a reamer to accommodate a duct approximately twice larger than the diameter of the export cable.
3. Once the drilling is completed, a duct will be pushed in from the land side to offshore exit point, using pipe thruster and assisted by divers.

Once duct installation is complete, the duct exit will be prepared with a bellmouth and a messenger wire will be installed through the duct. The duct exit will also be sealed and protected in preparation for cable pull-in activities.

#### **4.8.4.2 Seabed preparations**

A PLGR vessel will be mobilised together with the required survey and positioning equipment, grapnel train and towing winch with the required rendering capacities to remove any debris, such as fishing gear, from the cable route. See Section 4.6.3.2 for details on how a PLGR is executed.

It is expected that a boulder clearance campaign will be carried out prior the installation of the cable where boulders will be picked up using a boulder grab and relocated to outside the cable lay and trench corridor route approximately 10 to 15 m from their current location. For full details on boulder clearance see Section 4.2.2.

#### **4.8.4.3 Third-Party Crossing Preparation**

A total of four third-party crossings have been identified; one crossing OEC route 2 (OEC-2) and three crossings identified for OEC route 1 (OEC-1). Depending on the as-found condition of the seabed at that location, it may be required to install measures to guarantee the separation between the third-party asset and the Moray West OEC. Typically, this would comprise rock bags, grout bags, and, or concrete mattresses.

#### **4.8.5 Cable Installation**

OEC installation is expected to be carried out in two campaigns: Campaign 1 is expected to proceed between September 2023 and January 2024, and Campaign 2 between October 2023 and January 2024.

#### **4.8.5.1 Cable Lay**

Cable installation will commence at the landfall with cable pull-in through the installed ducts. A messenger wire is used to pull out the winch wire which gets connected to the pull-head on the cable onboard the CLV. The cables are then pulled into the ducts using a suitably sized winch located onshore. At the offshore end of the HDD, a dive team will be mobilized to do the necessary preparations of the HDD duct exit. The dive team will also perform necessary route clearance of rock debris which can potentially damage the cables in the vicinity of the HDD.

The cable laying operation for the OECs will proceed by laying the cable directly onto the seabed from the CLV, using a navigation system set up in such a way so that the vessel will travel along a pre-defined route (barge track) and lay the cable accordingly. The cable-lay operations will be monitored using an ROV to ensure that the cable is accurately laid, specifically across the third-party crossings and to avoid laying the cable on parts of the seabed that could cause damage the cable, e.g., avoiding creation of free-spans, sharp protrusions, etc. The as-laid position of the cable is determined by touchdown monitoring (TDM) during cable lay from CLV.

When the CLV approaches the OSP during the cable lay operations, the required cable length is calculated, and the cable is cut to length. Depending on the situation at the time of operation, there are three possible methods for preparation of cable pull-in at the OSP:

- the cable is laid onto the seabed just outside the J-tube and will remain in wet storage until pull-in operations are carried out (J-tubes will be capped until OSP pull-in operations are planned to begin);
- the cable is laid outside the 500 m zone of the OSP and will remain in wet storage until pull-in operations are ready to commence; or
- the cable is directly pulled into the OSP from the CLV.

The preferred method for OSP pull-in is through the use of a quadrant from the deck of the CLV, whereby a “bight” of cable will be supported from deck to seabed during the pull in. The cable end will be pulled into the OSP using a platform-mounted winch, and cable protection will be attached to the export cable on board the CLV prior to the pulling operation. Upon completion of the pull-in operation, the cable will be secured with the temporary hang-off clamps above the J-tube flange.

#### **4.8.5.2 Cable Burial**

The OEC routes feature a variety of soils along the routes, representative of the various geological and bathymetric conditions. The most appropriate tool will be selected at the time to achieve the most suitable possible cable burial.

A CBRA has been carried out to identify potential threats to the OECs and proposes burial depths to minimise risk from these threats and to protect the integrity of the installed cables.

The final position of the cable (after trenching) will be determined by means of a post-installation survey, carried out by using an ROV, moving along the cable route and recording the horizontal and vertical position of the cable relative to the seabed.

Where the minimum Depth of Lowering cannot be achieved, additional means of protection such as the use of rock berms or concrete mattresses will be employed.

The final details of the planned rock placement e.g., crossings and any remedial protection works and their locations along each of the cable routes will be confirmed following completion of the burial works.

#### **4.8.6 Terminations and Testing**

Following cable pull-in, the cable will be routed within the OSP structure and connected to the cable end terminations.

Similarly onshore at the TJB, the OEC and onshore export cable (ONEC) will be jointed together once each circuit is completed. The electrical cables and their associated fibre optic cable will be tested between the onshore substation and the respective OSP prior to first energisation.

#### **4.9 Electrical Infrastructure Commissioning**

Following completion of the physical installation of the components that make up the Development, the OfTI will be commissioned and energised, allowing the Wind Farm to be commissioned and brought into commercial operation.

Commissioning and energisation of electrical infrastructure will involve the following principal activities:

- energisation of the onshore infrastructure associated with the Development;
- energisation of each of the offshore export cables;
- energisation and commissioning of electrical equipment on the OSPs;
- energisation of the IAC network; and
- energisation and commissioning of electrical equipment on the WTGs.

As the OfTI utilises equipment operating at voltages up to 220 kV, electrical infrastructure commissioning will be undertaken in accordance with high voltage safety rules that will be put in place by Moray West in line with industry practice.

The offshore commissioning works will be undertaken by personnel who will transfer on a daily basis to the Development site from a local commissioning port base using CTV. An offshore accommodation vessel may be deployed at peak times.

## 5 Good Working Practices

### 5.1 Introduction

Good working practice is considered to reach or exceed the requirements of the offshore consents (S36 and Marine Licences; see Appendix B). For the purposes of complying with this requirement, Moray West have taken the requirement to imply the following:

*The reasonable application of methods of working that have been shown to achieve the best outcomes or that reach or exceed relevant legislative standards.*

In the context of the construction of the Development, this has been taken to apply to those standards, guidance or examples of good practice working that will act to:

- manage the construction process so as to avoid harm to construction personnel or third parties; and,
- ensure effects on the environment and other users of the marine environment are minimised as far as reasonably practicable (and in line with the commitments made by Moray West or the requirements of the offshore consents as described in Section 1.1).

The following sections set out the areas of good working practices that will be applied during the construction process described by this CoP and CMS. They address the following specific areas:

- offshore renewable industry good practice guidance;
- health and safety procedures;
- construction management procedures;
- environmental management procedures; and
- specific good working practices in relation to aspects of the construction process (as set out in Section 5.5 of this CoP and CMS) that, for example, act to avoid or reduce environmental impacts or impacts on other users.

Cross reference is made to other relevant consent plans (as described under Section 1.3 of this CoP and CMS).

### 5.2 Offshore Renewable Industry Good Working Guidance

There are a number of good practice guidance documents that have been produced for or in relation to the offshore renewables industry in recent years. Where relevant, Moray West will require that such good practice is reflected in the detailed method statements produced by the key contractors and sub-contractors. Industry guidance documents are listed in Table 12 below.

Moray Offshore Windfarm (West) Limited  
 Construction Programme and Construction Method  
 Statement



8460005-DBHA03-MWW-PLN-000001

Table 12: Industry guidance documents for good working practice		
Produced by	Title	Scope
The G9, published through the Energy Institute	Working at height in the offshore wind industry (published November 2014)	Covering design, construction, commissioning, and operation; designed to reduce the need for work at height; topic guidance sheets, covering common hazards, personal protective equipment, training and competence, fitness requirements, and the responsibilities of those procuring, supervising and undertaking work; with supporting information, such as regulatory requirements in selected EU countries and technical standards.
	The safe management of small service vessels used in the offshore wind industry (2 <sup>nd</sup> Edition) (published January 2018)	Cover working with vessels that have a gross tonnage of less than 500, such as crew transfer vessels, guard vessels, survey vessels and construction support vessels. The guidelines cover audit and inspection regimes for Wind Farm service vessels, operating procedures for routine marine operations, training and competence of crew and passengers, and safety equipment.
The Crown Estate	Sharing lessons learned and good practice in offshore transmission (published June 2014)	Presents the findings from a study commissioned to understand experience and lessons learned in the development, construction and operation of offshore transmission infrastructure.
	Construction vessel guideline for the offshore renewables industry (Published September 2014)	This guideline is designed to follow on from Vessel safety guide 'Guidance for offshore renewable energy developers (Vessel safety guide)' published by RenewableUK in January 2012 and is intended to assist by providing guidance to developers and the supply chain for the construction of an UK offshore Wind Farm project.
RenewableUK	Offshore Wind and Marine Energy Health and Safety (H&S) Guidelines (published March 2014)	H&S guidelines for the offshore wind sector covering all phases of development and identifying risks and significant safety hazards and activities.
	Integrated Offshore Emergency Response – Renewables (IOER-R) – Good Practice Guidelines for Offshore Renewable Energy Developments (Published 2016)	Sets out a recommended approach for managing and responding to emergencies taking account of existing and emerging industry good practice within the framework of UK health and safety legislation.

# Moray Offshore Windfarm (West) Limited Construction Programme and Construction Method Statement



8460005-DBHA03-MWW-PLN-000001

Table 12: Industry guidance documents for good working practice		
Produced by	Title	Scope
	Safety Circular: Notices to Mariners. Guidance for Offshore Wind & Marine Projects (Published 2013)	This Circular provides a short summary of the accepted scope and format for issuing Notice to Mariners (NtMs).
	FLOWW Best Practice Guidance for Offshore Renewables Developments: Recommendations for Fisheries Liaison (Published January 2014)	Sets out best practice guidance on liaison between the offshore wind industry and the fishing industry.
	Guidelines for Selection and Operation of Jack-ups in Marine Renewable Energy Industry (Published February 2013)	Industry guidance aimed at jack-up owners, operators, developers and contractors engaged in site-investigation, construction, operation and maintenance of offshore wind and marine energy installations.
	H&S First Aid Needs Assessment (Published August 2013)	Provide basic information on how duty holders can assess the provision of adequate and appropriate equipment, facilities and personnel to ensure employees receive proper attention if they are injured or taken ill at work.
	Vessel Safety Guide Guidance for Offshore Renewable Energy Developers (2015)	Provides guidance and insight on the selection of vessels through all phases of Wind Farm development.

### 5.3 Construction Management Procedures

Moray West will ensure a range of project management procedures are in place during the construction process that will, alongside the relevant approved consent plans, act to ensure the safe, compliant installation of the major project components as described in this CoP and CMS, including but not limited to:

- a dedicated marine coordination centre to coordinate all activities on site including all vessel and personnel movements, electrical switching and site surveillance;
- detailed construction method statements and risk assessments prepared by each of the main contractors;
- appropriate interface management procedures;
- a detailed integrated construction programme maintained regularly with input from the main contractors;



- clear roles and responsibilities allocated to all parties (see also Section 3 above);
- appropriate and regular communications between all contracted parties and with relevant third parties;
- marine warranty survey involved in the review of documentation and present at certain key construction activities where required under the terms of the project's insurances;
- independent verification of key elements of design; and
- a clear process of reporting, recording and auditing of the construction process, contractor performance and methods for managing shortfalls in performance.

#### **5.4 Environment Management Measures**

The environmental management measures that will be applied by Moray West personnel and contractors incorporate a variety of good working practice and legislative standards in relation to the control of waste, dropped objects, pollution prevention, chemical usage, control of invasive non-native species, etc. Environmental management measures are set out in the EMP and will be applied when undertaking the proposed construction works set out in this CoP and CMS.

#### **5.5 Project-Specific Good Working Practices**

There are a number of specific good working practices that will be applied to certain aspects of the construction process as set out in this CoP and CMS and that will seek to minimise the environmental effects arising from the construction. The following sections set out the good working practices related to:

- grouting operations;
- seabed preparation and jack-up usage;
- cable and scour protection;
- piling operations;
- drilling muds;
- cable installation; and
- minimising effects on other sea users.

##### **5.5.1 Grouting**

Grout will be used to connect the OSP topside to the transition piece as well as to seal the annulus between the monopile external wall and transition piece skirt internal wall. The volumes of grout required will be minimised as far as possible through design. Grout loss will be minimised by the monitoring and control of grout volumes being injected into each joint. Any spilt grout will be collected on the OSP cable deck/TP air tight platform and be removed at the end of the operations.

### 5.5.2 Seabed Preparation and Anchor / Jack-up Movements

Where a JUV is to be used, its movements and leg re-positioning will be minimised through the design of installation process so as to avoid unnecessary disturbance to seabed habitats. Similarly, anchor movements will be minimised.

### 5.5.3 Piling Operations

Soft start piling procedures will be applied at the start of piling operations as part of the marine mammal mitigation protocol. Full details of the piling approach and wider marine mammal mitigation is set out in the PS.

### 5.5.4 Cable Installation

Where possible during cable installation, cable burial will be completed by the use of a jet trenching tool. These tools use a high-pressure water jet to fluidise the seabed soils allowing the cable to sink under its own weight to the target burial depth. They rely on the disturbed sediment settling back into the cable trench to create cover / backfill on top of the cable as the trenching tool passes.

### 5.5.5 Minimising Effects on Other Sea Users

Moray West recognises that the Development represents a major infrastructure construction project in the waters of the Moray Firth that are also used by a variety of other marine users including other commercial shipping, the commercial fishing industry, and recreational sailors.

In order to ensure that effects on these other marine users are minimised, standard good working practices will be employed to ensure effective communication to minimise interactions and communicate risks arising from construction works to others in the vicinity of the construction site. A number of these are specific requirements of the consents but also represent good working practice, including:

- the regular issuing of NtMs and Weekly Notices of Operations;
- the issuing of Vessel Reports (detailing the vessels involved in construction works) on the Moray West project website ([www.moraywest.com](http://www.moraywest.com));
- the issuing of Notice to Airmen (NOTAM) for movements of vessels with structures or equipment above 60 m;
- charting on nautical and aviation charts in line with regulatory requirements (provision of information to the United Kingdom Hydrographic Office (UKHO));
- lighting of temporary and partially installed structures during construction;
- establishment of safety zones during construction;
- use of radio navigation warnings;
- appointment of a suitably qualified FLO;
- notification of commencement and completion of the works to local mariners, fishermen's organisations and HM Coastguard and Buckie Harbour Master by use of NtMs;

# Moray Offshore Windfarm (West) Limited Construction Programme and Construction Method Statement



8460005-DBHA03-MWW-PLN-000001

- notification of details of the works through Kingfisher and provision of information to the SeaFish industry on vessel routes, timings and location of the works and relevant operations;
- provision of details on the location of the Development for inclusion in the Clyde Cruising Club Sailing Directions and Anchorages; and
- direct engagement and regular communication with other stakeholders such as owners of existing infrastructure in the Moray Firth.

**Moray Offshore Windfarm (West) Limited**  
**Construction Programme and Construction Method**  
**Statement**



8460005-DBHA03-MWW-PLN-000001

**Appendix A – Defined Terms**

<b>Term</b>	<b>Description</b>
Design Envelope	The range of design parameters used to inform the assessment of impacts.
Marine Licence for the Generating Station	Marine Licence for the Moray West Offshore Wind Farm - Licence Number: MS-00008731 - granted under the Marine and Coastal Access Act 2009, Part 4 Marine Licensing for marine renewables construction works and deposits of substances or objects in the Scottish Marine Area and the UK Marine Licensing Area granted to Moray West on 14 June 2019 and varied on 7 March 2022 and 11 April 2022 (as MS-00009774).
Marine Licence for the Transmission Works	Marine Licence for the Offshore Transmission Infrastructure – Licence Number MS-06764/19/0 – granted under the Marine and Coastal Access Act 2009, & Marine (Scotland) Act 2010, Part 4 Marine Licensing for marine renewables construction works and deposits of substances or objects in the Scottish Marine Area and the UK Marine Licensing Area (referred to as the “OfTI Marine Licence”), granted to Moray West on 14 June 2019 and varied on 11 April 2022 (as MS-00009813) and 8 February 2024 (as MS-00010585).
Moray Offshore Windfarm (West) Limited	The legal entity submitting this Construction Programme and Construction Method Statement (CoP & CMS).
Moray West EIA Report	The Environmental Impact Assessment Report for the Moray West Offshore Wind Farm and Associated Transmission Infrastructure, submitted July 2018. Additional information was provided in the Moray West Report to Inform an Appropriate Assessment (RIAA) July 2018 and Moray West Application Addendum Document November 2018.
Moray West Offshore Wind Farm	The wind farm to be developed in the Moray West site (also referred as the Wind Farm).
Offshore Consents	Collective term for the two Marine Licences and the Section 36 consent
Offshore Consent Conditions	Collective term for the conditions attached to the Section 36 Consent and Marine Licences
Offshore Transmission Infrastructure (OfTI)	The offshore elements of the transmission infrastructure.
OfTI Corridor	The export cable route corridor, i.e., the OfTI area excluding the Moray West site.
Section 36 Consent	Section 36 consent under Section 36 of the Electricity Act 1989 for the construction and operation of the Moray West Offshore Wind Farm was granted on 14 June 2019 and varied on 7 March 2022.
The Development	The Moray West Offshore Wind Farm and OfTI.
The Development Site	The area outlined in Figure 1 attached to the Section 36 Consent Annex 1, Figure 1 attached to the two Marine Licences, and Figure B.1 of this CoP & CMS.

**Moray Offshore Windfarm (West) Limited**  
**Construction Programme and Construction Method**  
**Statement**



8460005-DBHA03-MWW-PLN-000001

The Moray West Site	The area in which the Moray West Offshore Wind Farm will be located. Section 36 Consents and associated Marine Licence to construct and operate generating stations on the Moray West site were granted in June 2019 and varied in March 2022.
The Works	The construction and O&M activities undertaken for the Development.
Transmission Infrastructure (TI)	Includes both offshore and onshore electricity transmission infrastructure for the consented wind farm. Includes connection to the national electricity transmission system near Broad Craig in Aberdeenshire encompassing Alternating Current (AC) Offshore Substation Platforms (OSPs), AC export cables offshore to landfall point at Broad Craig, near Sandend in Aberdeenshire continuing onshore to the AC collector station (onshore substation) at Whitehillock and the additional regional Transmission Operator substation at Blackhillock near Keith. A Marine Licence for the OfTI was granted in June 2019 and varied on 11 April 2022 and 8 February 2024.

## Appendix B – Development Background Information

### B.1 Development Description

Moray West Offshore Wind Farm is being developed by Moray Offshore Windfarm (West) Limited (Moray West; Company Number 10515140) which is registered at Octagon Point, 5 Cheapside, London, England, EC2V 6AA. Moray Offshore Windfarm (West) Limited is a wholly owned subsidiary of Moray West Holdings Limited which in turn is owned by Moray Offshore Renewable Power Limited, Delphis Holdings Limited, EDP Renewables Europe, S.L.U and UAB Ignitis Renewables.

The Moray West Site covers an area of approximately 225 km<sup>2</sup> on the Smith Bank in the Outer Moray Firth approximately 22 km from the Caithness coastline.

The Moray West Offshore Wind Farm will comprise 60 wind turbine generators (WTGs), associated substructures and seabed foundations, IACs, one OSP inter-connector cable and any scour protection around substructures or cable protection. The OfTI comprises two offshore substation platforms (OSPs) which will be located within the Moray West Site and two offshore export cable circuits which will be located within the OfTI Corridor and will be used to transmit the electricity generated by the offshore wind farm to shore.

The offshore export cable circuits will come ashore at Sandend Bay, which is located on the Aberdeenshire Coast at Broad Craig, approximately 65 km south of the Moray West Site. There will be two underground circuits from landfall at Sandend Bay to Whitehillock where the onshore substation will be located. There will also be further underground cabling between Whitehillock substation and Blackhillock substation. Moray West will transfer ownership of the transmission asset to an Offshore Transmission Owner (OFTO) who will manage the transmission infrastructure.

Figure B.1 displays a map of the Moray West Site and OfTI Corridor.

The development is aiming to be fully operational in 2024/25 with an operational life of 25 years from the date of final commissioning of the Development.

# Moray Offshore Windfarm (West) Limited Construction Programme and Construction Method Statement



8460005-DBHA03-MWW-PLN-000001

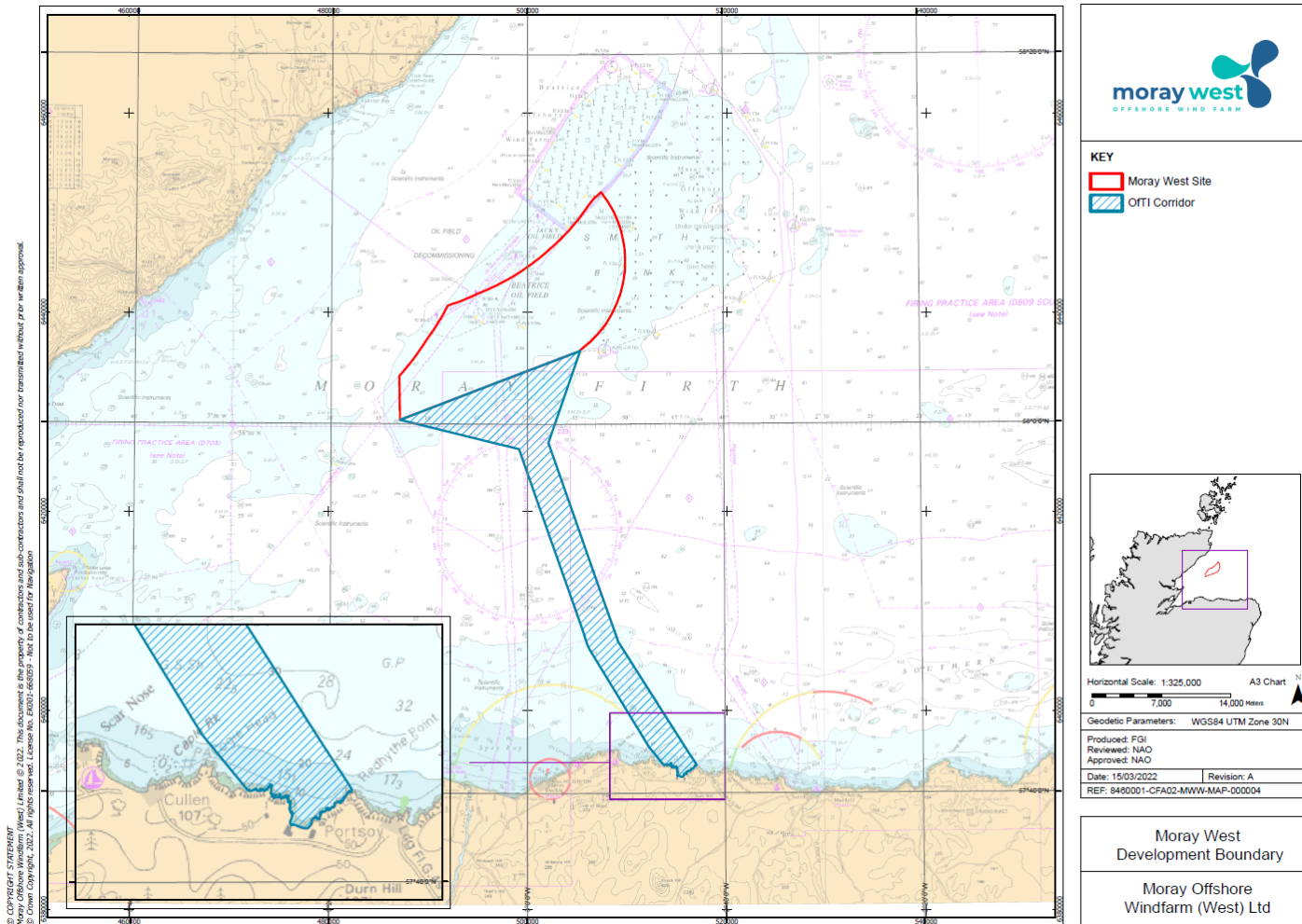

Figure B.1 Geographical location of the Moray West Site and OfTI Corridor

# Moray Offshore Windfarm (West) Limited Construction Programme and Construction Method Statement



8460005-DBHA03-MWW-PLN-000001

## B.2 Legal Context

Table B.1 provides a list of S36 and marine licence consent conditions relevant to this CoP and CMS and how they are addressed within it.

Table B.1. Consent conditions to be discharged by this CoP and CMS		
Consent Condition Reference	Condition	Addressed
S36 consent Condition 9 Wind Farm Marine Licence MS- 00009774 Condition 3.2.2.6 OfTI Marine Licence MS-00010585 Condition 3.2.2.5	The Company must, no later than six months prior to the Commencement of the Development, submit a Construction Programme (“CoP”), in writing, to the Scottish Ministers for their written approval. Such approval may only be granted following consultation by the Scottish Ministers with Scottish Natural Heritage (“SNH”), Aberdeenshire Council, Scottish Fishermen’s Federation (“SFF”) and any such other advisors or organisations as may be required at the discretion of the Scottish Ministers. Commencement of the Development cannot take place until such approval is granted.	This document sets out the CoP for approval by the Scottish Ministers. Consultation to be undertaken by the Scottish Ministers.
	The CoP must set out:	
	a) The proposed date for Commencement of the Development;	Section 2.2.1
	b) The proposed timings for mobilisation of plant and delivery of materials, including details of onshore lay-down areas;	Section 4
	c) The proposed timings and sequencing of construction work for all elements of the Development infrastructure;	Section 2
	d) Contingency planning for poor weather or other unforeseen delays; and	Section 2.4
	e) The scheduled date for Final Commissioning of the Development.	Section 2.2.4
The final CoP must be sent to Aberdeenshire Council, Maritime and Coastguard Agency (“MCA”), Northern Lighthouse Board (“NLB”), Moray Council and the Highland Council for information only.	The Final CoP and CMS will be sent to Aberdeenshire Council, MCA, NLB, Moray Council and the Highland Council for information only	



Moray Offshore Windfarm (West) Limited  
Construction Programme and Construction Method  
Statement



8460005-DBHA03-MWW-PLN-000001

Table B.1. Consent conditions to be discharged by this CoP and CMS		
Consent Condition Reference	Condition	Addressed
S36 consent Condition 10 Wind Farm Marine Licence MS- 00009774 Condition 3.2.2.7 OfTI Marine Licence MS-00010585 Condition 3.2.2.6	The Company/Licencee must, no later than six months prior to the Commencement of the Development submit a Construction Method Statement (“CMS”), in writing, to the Scottish Ministers for their written approval. Such approval may only be granted following consultation by the Scottish Ministers with SNH, MCA, NLB, SFF, Aberdeenshire Council, <b>RSPB Scotland (Wind Farm Marine Licence only)</b> , <b>SEPA, Mountaineering Scotland (OfTI Marine Licence only)</b> and any such other advisors or organisations as may be required at the discretion of the Scottish Ministers. Commencement of the Development cannot take place until such approval is granted. The CMS must include, but not be limited to:	This document sets out the CMS for approval by the Scottish Ministers. Consultation to be undertaken by the Scottish Ministers.
	a) Methods of construction as they relate to all aspects of the Development. <b>(S36 and OfTI marine licence only)</b>	Section 4
	b) Details of the commencement dates, duration and phasing for the key elements of construction, the working areas, the construction procedures and good working practices for installing the Development.	Section 2 and Section 4
	c) Details of the roles and responsibilities, chain of command and contact details of company personnel, any contractors or sub-contractors involved during the construction of the Development.	Section 3 Contact details are not detailed within Section 3. Moray West will collate key personnel contact details into a Project Contact Register. This will be provided to MD-LOT separately once available and prior to Construction.
d) Details of the manner in which the construction related mitigation steps proposed in the Application are to be delivered.	Various sections throughout this document and	

Moray Offshore Windfarm (West) Limited  
 Construction Programme and Construction Method  
 Statement



8460005-DBHA03-MWW-PLN-000001

Table B.1. Consent conditions to be discharged by this CoP and CMS		
Consent Condition Reference	Condition	Addressed
		<p>other consent plans.</p> <p>Detailed method statements and associated mitigation measures (as relevant) with regards to piling activities, cable laying and management of construction activities are covered in other plans such as the DS, DSLP, EMP, VMNSP, PS, ECP and the LMP. This CoP and CMS document provides an overview of the construction activities, which will be aligned with more detailed information as set out in these plans.</p>
	<p>The CMS must adhere to the construction methods assessed in the Application. The CMS also must, so far as is reasonably practicable, be consistent with the Design Statement (“DS”), the Environmental Management Plan (“EMP”), the Vessel Management Plan (“VMP”), the Navigational Safety Plan (“NSP”), the Piling Strategy (“PS”), the Cable Plan (“CaP”) and the Lighting and Marking Plan (“LMP”).</p>	<p>The CMS has been written to, as far as is reasonably practicable, be consistent with the DS, EMP, VMNSP, PS, Cable Plans and LMP</p>
	<p>The final CMS must be sent to Moray Council and the Highland Council for information only.</p>	<p>The Final CoP will be sent to Moray Council and the</p>

Table B.1. Consent conditions to be discharged by this CoP and CMS		
Consent Condition Reference	Condition	Addressed
		Highland Council for information only

### B.3 Sustainable Construction

The Institute of Environmental Management and Assessment (IEMA) state “Sustainable Construction” as *“application of sustainable development to the construction industry, whereby the construction and management of a development is based on principles of resource efficiency and the protection/enhancement of natural and built heritage. Sustainable construction comprises such matters as site planning and design, material selection, resource and energy use, recycling and waste minimisation”*. (Institute of Environmental Management and Assessment, Environmental Management Plans Practitioner, Volume 12, December 2008).

Moray West is fully committed to ensuring that the Development staff and stakeholder needs and expectations are met and exceeded, achieving the ultimate goal of delivering the Development to the highest standard of quality, with a Zero Harm approach to the health and safety of individuals and to the environment as a whole. Moray West have developed an overarching QHSE Policy, which includes the following objectives:

- To reduce our carbon footprint by conserving natural resources and reducing energy use and waste generated by our operations; and
- To support and maintain our commitment to the protection of the environment, including prevention of pollution and other specific commitment(s) relevant to the context of the organisation’s undertakings.

This EMP provides a framework, supported by Moray West’s QSHE Policy, the organisational context, the EIA and associated documents, the consent plans (including the WMP and MPCP) and the output of hazard identification processes, to aid Moray West in achieving its own environmental objectives:

- Zero spills to sea.
- Zero high potential incidents.
- All personnel working on the Development shall have a risk assessment for every task, which also addresses environmental impact.

# Moray Offshore Windfarm (West) Limited Construction Programme and Construction Method Statement



8460005-DBHA03-MWW-PLN-000001

- Responsible construction and compliance with all applicable legislation, licences and conditions and best practice guidance.
- Consideration of local supply chain and use of sustainable materials where possible.
- Use of the waste hierarchy of reduce, reuse and recycle wherever possible.
- Incorporation of 'lessons learnt' into ongoing works for continued HSE improvement