



# **Nova Innovation | OCEANSTAR Project**

## **Navigational Risk Assessment Addendum**

### **EMEC Fall of Warness**

**December 2023**



*Copyright © EMEC 2023*

---

## Document History

Revision	Date	Description	Originated by	Approved by
1.0	21/12/23	Final draft for issue to MD-LOT	Kate Smith	Gavin McPherson

---

## Disclaimer

This document entitled Nova Innovation OCEANSTAR Project Navigational Risk Assessment Addendum EMEC Fall of Warness has been prepared by Nova Innovation Ltd. This document in whole or in part may not be used by any person for any purpose other than that specified, without the express written permission of Nova Innovation.

Any liability arising out of use by a third party of this document for purposes not wholly connected with the above shall be the responsibility of that party who shall indemnify Nova Innovation against all claims costs damages and losses arising out of such use.

## Purpose

This document is provided as an addendum to, and should be read in conjunction with, the document 'Fall of Warness Tidal Site Navigational Risk Assessment (NRA) – REP315'. It describes the key project-specific navigational risks to be addressed in relation to the proposed activities associated with the OCEANSTAR Project at the Fall of Warness site, European Marine Energy Centre, Orkney Islands, together with proposed mitigation for reduction/elimination of these risks. Site location navigational risks are covered in the site-wide Fall of Warness NRA produced by EMEC.

This document has been prepared to support a marine licence application for Nova Innovation's OCEANSTAR Project. For further information regarding the project, please refer to the Project Information Document<sup>1</sup>.

---

<sup>1</sup> OCEANSTAR Project Information Document, EMEC Fall of Warness. December 2023.

---

## Contents

1	Introduction .....	6
2	Project overview.....	6
3	Deployment location .....	7
4	Asset information .....	9
4.1	Tidal turbines .....	9
4.2	Offshore electrical hub .....	11
4.3	Intra-array cables.....	11
4.4	Export cable.....	11
4.5	Third party verification.....	11
5	Project schedule .....	12
5.1	Overview.....	12
5.2	Site preparation .....	12
5.3	Installation .....	12
5.4	Operation and maintenance.....	14
5.5	Removal and decommissioning .....	15
5.6	Vessels .....	15
6	Consultation.....	16
7	Key navigational themes.....	16
7.1	Vessel routing .....	16
7.2	Contact / allision risk.....	17
7.3	Under keel clearance .....	18
7.4	Collision risk and visual navigation.....	19
7.5	Communication, radar and positioning system.....	19
7.6	Moorings and buoys.....	19
7.7	Station keeping .....	20
7.8	Fishing activity .....	20
7.9	Recreational activity.....	20
7.10	Subsea cables .....	20
7.11	Search and rescue.....	21
7.12	Cumulative and in-combination.....	21
8	Risk controls .....	21
8.1	Site-wide risk controls .....	21

---

8.2	Project-specific risk controls.....	23
9	Summary and conclusion.....	24

---

## 1 Introduction

Nova is one of the world's leading players in driving forward the development of the nascent tidal stream energy industry. Nova was the first in the world to deploy an offshore array of tidal stream turbines (in 2016 in Bluemull Sound, Shetland). Of approximately fifteen offshore tidal stream turbines that are currently deployed around the world, three are Nova's: designed and manufactured in Scotland. Headquartered in Edinburgh, Nova currently employs more than 30 staff.

Nova's 10 MW OCEANSTAR Project will involve the deployment of up to nineteen of Nova's next generation M-series direct drive seabed-based turbines in the Fall of Warness site at EMEC, Orkney Islands.

The OCEANSTAR Project will be implemented under EMEC's site-wide licence issued by Marine Scotland (operational name) on behalf of Scottish Ministers under Section 36 of the Electricity Act 1989 for the Fall of Warness. **EMEC and Nova will work together to manage installation of OCEANSTAR Project offshore infrastructure and associated activity to ensure that the project is installed and operates in accordance with site-wide consents. The total number of devices (or any other parameter) will not breach any limit in the overarching section 36 consent for Fall of Warness.**

This Navigational Risk Assessment (NRA) has been produced as an addendum to the site-wide NRA for the Fall of Warness site (REP315) to support Nova's project-specific marine licence application to Scottish Government's Marine Directorate for the OCEANSTAR Project under the Marine (Scotland) Act 2010. All project-specific navigational risks are identified and assessed. The proposed control measures to be implemented to reduce any navigational risk associated with the project are detailed.

## 2 Project overview

The OCEANSTAR Project will have a total installed capacity of 10 MW and will involve the deployment of up to nineteen of Nova's next generation M-series direct drive Oceanstar tidal turbines at the Fall of Warness site at EMEC, Orkney Islands. The total number of devices (or any other parameter) will not breach any limit in the overarching section 36 consent for Fall of Warness. An offshore electrical hub, intra-array cabling and a remote observation platform for environmental monitoring will also be installed as part of the OCEANSTAR Project.

The OCEANSTAR Project will be installed and commissioned in two phases. Phase 1 will comprise the installation, commissioning and monitoring of a single Oceanstar turbine in Q3/Q4 2025. All remaining turbines will be installed in Phase 2 in 2027. The OCEANSTAR Project will be operated at the Fall of Warness site for 25 years, following which decommissioning will take place in 2052.

Nova's next generation M-series Oceanstar turbine is a seabed-based horizontal axis direct drive tidal turbine. It is the culmination of 12 years of technology development, demonstration and refinement and will closely resemble the three Nova M100-D turbines currently deployed in the Shetland Tidal Array, Bluemull Sound, shown in Figure 1.

The Oceanstar turbine has been designed by Nova for operation in tidal sites of depths from 23 m to 53 m with maximum spring tide flow speeds of up to 4.5 m/s. The device consists of a gravity moored base structure, with a detachable steel nacelle containing the drive train, and two bladed horizontal axis rotor, designed for bi-directional operation, eliminating the need for a yaw

mechanism. The base consists of a 13 m high steel structure with concrete/steel ballast positioned on three feet.

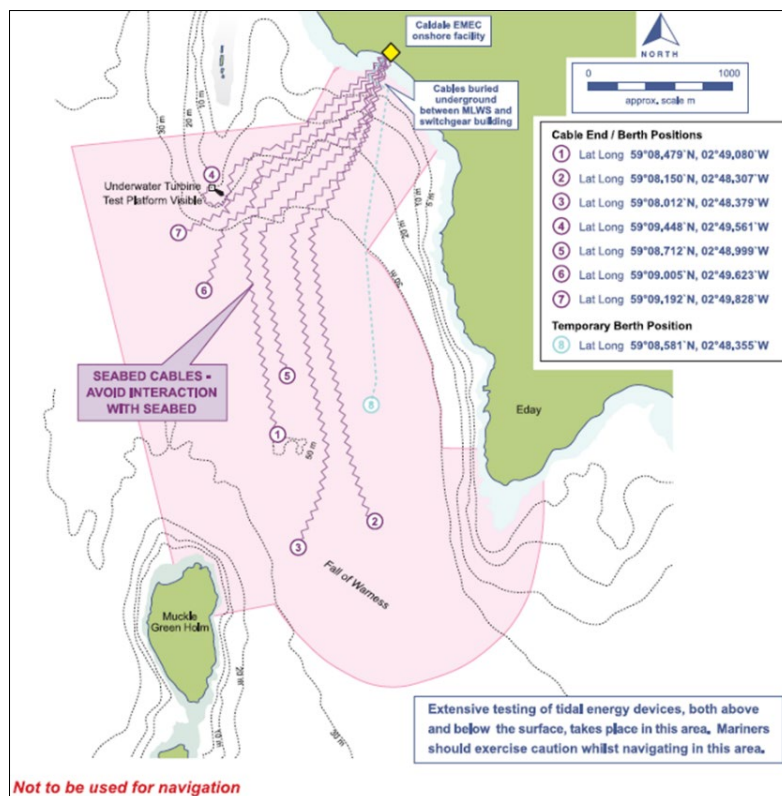

**Figure 1. Nova's M100-D turbine with its substructure being prepared for deployment at the Shetland Tidal Array, Bluemull Sound.** *Copyright © Nova Innovation 2020*

Details of the Oceanstar turbines and associated offshore infrastructure for the OCEANSTAR Project are provided in the following sections.

### 3 Deployment location

The turbines in the OCEANSTAR Project will be installed at EMEC's Fall of Warness site west of Eday, Orkney Islands, shown in Figure 2.



**Figure 2. EMEC Fall of Warness site.**

*Source: EMEC 2023*

Table 1 provides coordinates for the OCEANSTAR Project area at the Fall of Warness site. The array will be located within this area.

**Table 1. Coordinates of the OCEANSTAR Project area at the Fall of Warness.**

Location Description	Latitude and longitude (WGS 84)	UTM Eastings	UTM Northings
Array centre point	59° 08' 48.516" N 2° 49' 49.587" W	509700	6556411
OCEANSTAR Project area boundary points	59° 08' 58.524" N 2° 50' 26.736" W	509109	6556720
	59° 09' 12.611" N 2° 49' 29.143" W	510023	6557158
	59° 08' 11.029" N 2° 49' 59.275" W	509549	6555252
	59° 08' 10.975" N 2° 49' 18.196" W	510202	6555252

Source: Nova Innovation and EMEC 2023

The red quadrilateral box in Figure 3 shows the OCEANSTAR Project area at the Fall of Warness site. The precise location and layout of the turbines within this area will be finalised during the project development phase. The total number of devices deployed will not breach the limit in the overarching section 36 consent for Fall of Warness. A proposed location and layout for the array to the north of this Project area, based on a preliminary assessment are provided in Section 4.1. The coordinates of the central point of the proposed array location is provided in Table 1.

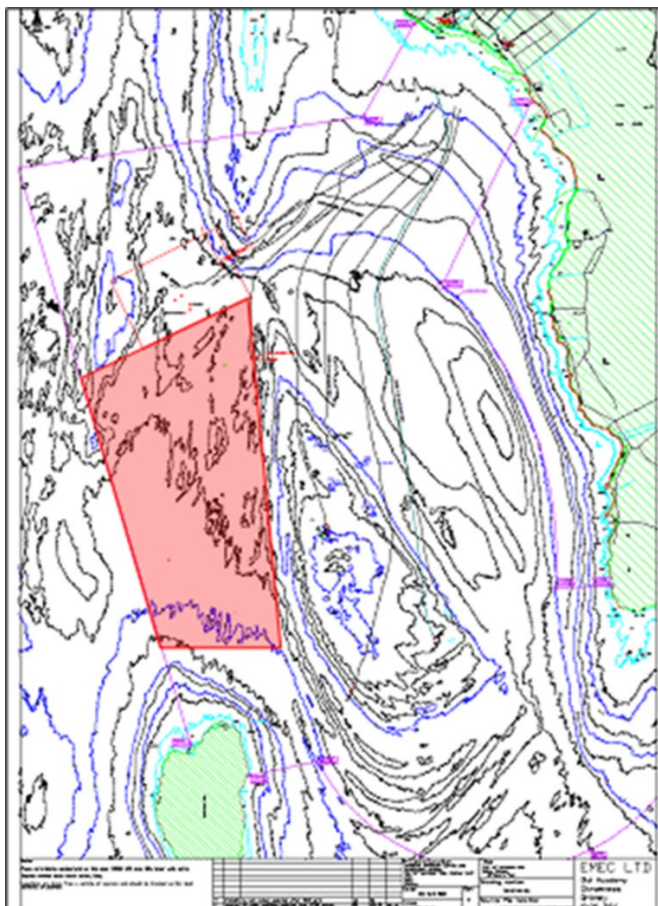

**Figure 3. Location of OCEANSTAR Project area at the Fall of Warness.**

Source: Nova Innovation and EMEC 2023

The OCEANSTAR Project offshore electrical hub will be located within the existing EMEC site boundary in a suitable site that complies with EMEC's site-wide Navigation Risk Assessment for the Fall of Warness. If the hub is a floating structure, it will likely be sited in a sheltered location,



agreed with EMEC and identified as being suitable for surface piercing devices. Careful micro-siting will be used for all project infrastructure, informed by discussions with navigational stakeholders, including Orkney Ferries, to ensure safe navigable channels. The hub will connect to export cable(s) that are connected to EMEC's onshore substation.

## 4 Asset information

### 4.1 Tidal turbines

Nova's Oceanstar turbine has a rotor diameter of 13.5 m, and a rotor hub height of 13 m. The total height from the bottom of feet to the tip of the blades is 19.75 m. The devices will be located at depths that ensure that during operation all parts of the turbine are at least 10 m below Lowest Astronomical Tide (LAT) to allow ample draft clearance for shipping (see also Section 7).

Each device uses a ballasted gravity foundation and therefore requires no other mooring system. Dimensions of the turbines are provided in Table 2 and Figure 4.

**Table 2. Key dimensions and weights of Nova's Oceanstar turbine.**

Parameter	Value
Nacelle weight	46 tonnes steel 7 tonnes other materials
Steel substructure weight (inc. cable attachment)	50 tonnes
Concrete ballast blocks (each)	9.5 tonnes (35 per turbine)
Total weight	435.5 tonnes
Rotor hub height	13 m
Rotor diameter	13.5 m
Blade tip height	19.75 m
Substructure plan view footprint	22m x 25m
Points of contact with seabed	3

Copyright © Nova Innovation 2023

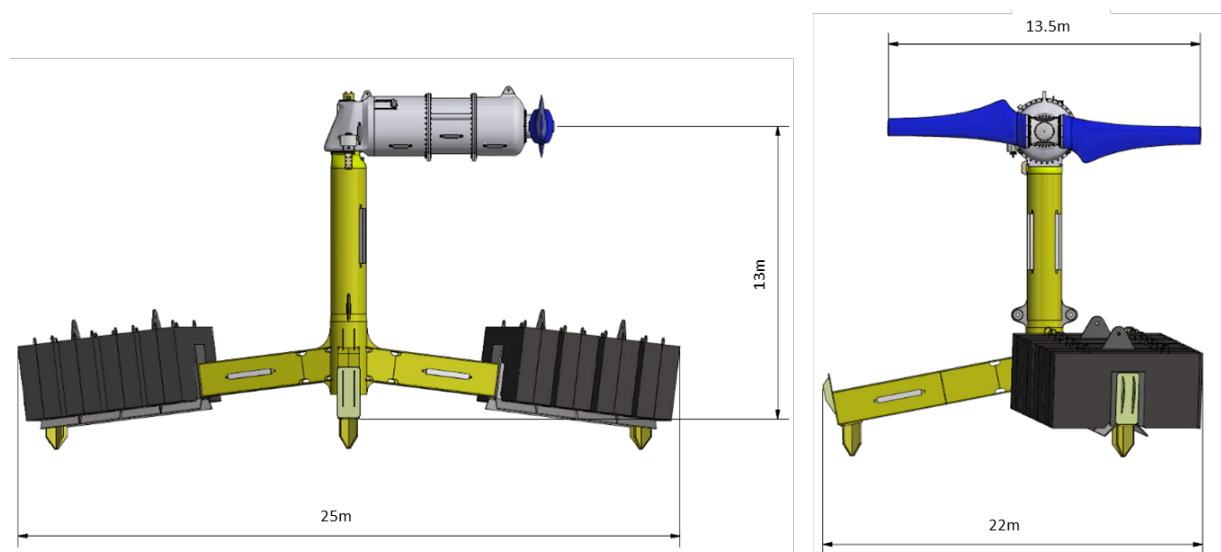

**Figure 4. Dimensions of Nova's Oceanstar turbine.**

Copyright © Nova Innovation 2023

The precise location and layout of the Oceanstar turbines in the array will be finalised during the project development phase. The total number of devices deployed will not breach the limit in the overarching section 36 consent for Fall of Warness. Figure 5 shows the currently proposed location and layout of the turbine array to the north of the OCEANSTAR Project area detailed in Section 3. The purple line shows the array boundary, with the proposed array layout of the turbines shown as one row of up to 10 turbines and one row of up to 9 turbines, delineated by the red rectangle. The turbines will be aligned such that their rotors are perpendicular to the primary flow. The central coordinates of this proposed array is provided in Table 1 above.

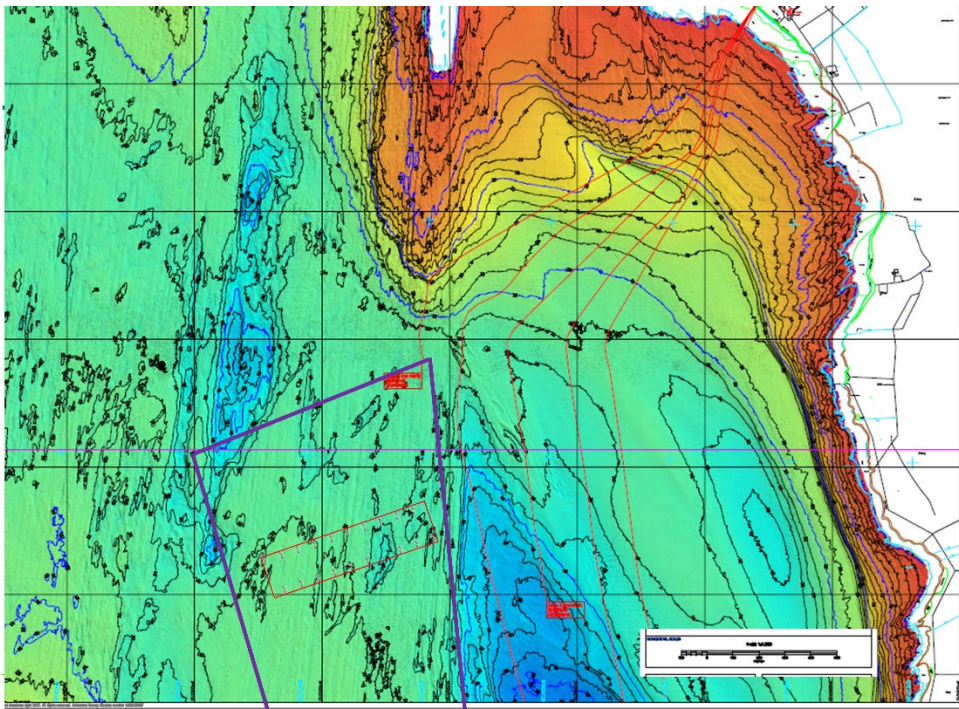

**Figure 5. Proposed layout of the turbines in the OCEANSTAR Project.**

Copyright © Nova Innovation 2023

Figure 6 shows the front elevation profile of the array, viewed from the north in the direction of flow.

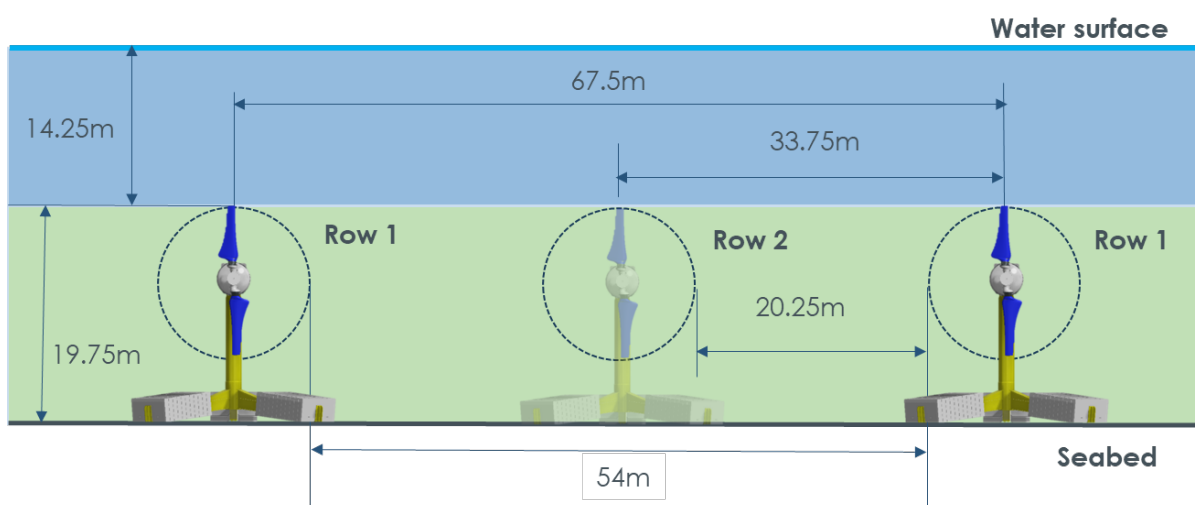

**Figure 6. Front elevation profile of the array viewed from the north.** Copyright © Nova Innovation 2023

---

Turbines within each row will be spaced 67.5 m apart (between rotor centres). The two rows of 10 turbines will be separated by 135 m. The total maximum array area will be approximately 175 m by 660 m. This proposed layout leaves ample room for navigation by vessels above the array – just as vessels have passed over Nova’s turbines in Bluemull Sound since 2014 without incident. This means there is no risk of interaction between the array turbines and navigation, including during poor weather when inter-island ferries may traverse this area.

## **4.2 Offshore electrical hub**

The OCEANSTAR Project will utilise an offshore electrical hub connected to the turbines via intra-array cables. The hub will connect to export cable(s) that are connected to EMEC’s onshore substation.

The hub will either be floating, fixed in place using an appropriate mooring system, or gravity-based on the seabed, but with the ability to be easily raised to the surface using temporary flotation. It will be marked with appropriate marking and lighting that complies with the relevant aspects of the International Regulations for Preventing Collisions at Sea COLREGS<sup>2</sup>, and the requirements of the Northern Lighthouse Board and the International Association of Marine Aids to Navigation and Lighthouse Authorities (IALA) to alert other mariners to the asset. Any floating or surface piercing component of the hub will be painted yellow and any Aids to Navigation will be visible to the mariner from all relevant directions in the horizontal plane, by day and night.

The hub will be located within the existing EMEC site boundary in a suitable site that complies with EMEC’s site-wide Navigation Risk Assessment for the Fall of Warness. If the hub is a floating structure, it will likely be sited in a sheltered location, agreed with EMEC and identified as being suitable for surface piercing devices. Careful micro-siting will be used for all project infrastructure, informed by discussions with navigational stakeholders, including Orkney Ferries, to ensure safe navigable channels. The hub will connect to export cable(s) that are connected to EMEC’s onshore substation.

## **4.3 Intra-array cables**

Intra-array cables will connect the turbines with the offshore electrical hub. They will carry both power and communication. All cables will consist of a number of copper conductors and optical fibres, protected by a double armour layer and HDPE sheath. The intra-array cables will be laid directly on the seabed, without the need for any additional protection (e.g., concrete mattresses). They are sufficiently heavy to remain in position without additional securing. The same cable specification has been successfully used at Bluemull Sound.

## **4.4 Export cable**

The OCEANSTAR Project will utilise export cables at EMEC that are connected to its onshore station.

## **4.5 Third party verification**

Details of the third party verification process are provided in the OCEANSTAR Project Information Document.

---

<sup>2</sup> Convention on the International Regulations for Preventing Collisions at Sea, 1972.

## 5 Project schedule

### 5.1 Overview

Prior to any installation works commencing, site investigations and preparation to inform OCEANSTAR Project development will be carried out. The OCEANSTAR Project will be installed and commissioned in two phases. Phase 1 will comprise the installation, commissioning and monitoring of a single Oceanstar turbine in Q3/Q4 2025. All remaining turbines will be installed in Phase 2 in 2027. The total number of devices (or any other parameter) will not breach any limit in the overarching section 36 consent for Fall of Warness. The OCEANSTAR Project will be operated at the site for 25 years, following which decommissioning of all offshore infrastructure will take place in 2052. The proposed OCEANSTAR Project schedule is outlined in Table 3.

**Table 3. Proposed OCEANSTAR Project schedule.**

STAGE	Year											
	2023	2024	2025	2026	2027	2028	...	2049	2050	2051	2052	
DEVELOPMENT												
PHASE 1 INSTALLATION												
PHASE 2 INSTALLATION												
OPERATIONAL PHASE												
DECOMMISSIONING												

The installation and commissioning of Phase 2 will take approximately 12 months, following which the array will be operated for up to 25 years. Decommissioning will take place over 28 weeks during 14 neap tides in the summer of 2052.

### 5.2 Site preparation

Site preparation will be minimal, consisting of existing cable inspection, and seabed and tidal current (ADCP) surveys.

### 5.3 Installation

The OCEANSTAR Project will be installed and commissioned in two phases. Phase 1 will comprise the installation of a single Oceanstar turbine in Q3/Q4 2025. All remaining turbines will be installed in Phase 2 in 2027. The total number of devices (or any other parameter) will not breach any limit in the overarching section 36 consent for Fall of Warness.

Tidal turbines and offshore infrastructure associated with the OCEANSTAR Project will be installed using methodologies developed, refined and demonstrated by Nova in the successful deployment of six devices in the Shetland Tidal Array. As with operations conducted by Nova in Shetland, a Multicat vessel will be used, with either a 4-point mooring or dynamic positioning system for positioning when required.

A detailed Construction Method Statement will be supplied post-consent. All installation methods will be within the project envelope specified for the Section 36 licence for the Fall of Warness. The total number of devices deployed will not breach the limit in the overarching section 36 consent for Fall of Warness.

Offshore infrastructure installation will take place in the following sequence:

1. **Load-out turbine substructure and ballast.**  
The turbine substructure and concrete ballast units will be assembled at a nearby facility or barged to load-out location. A crane will transfer the steel substructure into the water.
2. **Ballast turbine substructure.**  
The substructure will be picked up with a Multicat and transported to a sheltered local position near to the deployment site. The Multicat will pick up the ballast units and lower them onto the relevant locations on the turbine substructure.
3. **Deploy turbine substructure.**  
The ballasted substructure will be picked up and transited the short distance to the deployment location. Once on site, the ballasted substructure will be lowered to the seabed with equipment used to control the position and orientation of this once deployed. Remaining ballast will be deployed on-site, as demonstrated at the Shetland Tidal Array.
4. **Deploy offshore electrical hub and carry out shore cable connection.**  
The offshore electrical hub will be transported by Multicat vessel from Kirkwall harbour. The Multicat will recover the export cable and connect it to the offshore hub. The hub will be made secure at its final location and marked using buoys and lights as required.
5. **Deploy intra-array cables.**  
Intra-array cables will be installed using a Multicat vessel from a nearby pier. Using 4-point mooring or DP control, the Multicat will lower the turbine-end of each cable (known as a backpack) onto the corresponding substructure. The cable will then be laid until clear of the substructure area. Once released from the moorings (if used), the cable will be laid along a predetermined course (avoiding other array components) to the offshore hub, where it will be connected. This process will be repeated for all intra-array cables. No additional deposits are expected to be required to secure the cables.
6. **Deploy nacelle.**  
The Multicat vessel will collect the turbine nacelle from Kirkwall Harbour and carry it to the installation location. The nacelle will be lowered from the vessel to the substructure, to which it will be mechanically locked. The electrical connection is made by a remotely actuated wet-mate connector.

Installation operations will typically take place during neap tides and, when possible, will be scheduled during the summer months for improved weather and daylight conditions. However Nova has experience in Shetland deploying, recovering and decommissioning devices in all seasons and during neap and spring tides.

Offshore operations will be carried out during appropriately slack tides with suitable wave and weather conditions. The installation will be managed by Nova Innovation staff who will be resident in Orkney for the project. All work will be accompanied by the relevant notifications.

## 5.4 Operation and maintenance

Once installed, Nova will carefully manage and control turbine commissioning using a stepwise procedure implemented over a three to four week period, during daylight hours and encompassing a full neap-spring tidal cycle. The initial stages of turbine commissioning are externally powered (motoring mode). Active blade rotation powered by tidal flow (generating mode) is only introduced in later stages. Following successful commissioning of the turbines the array will operate for a period of 25 years to 2052.

Throughout the operational phase, performance monitoring of the turbines will be undertaken remotely via a fibre optic cable. This will allow the devices to be monitored either from the shore or remotely via a secure internet connection in the EMEC substation on Eday.

The fibre optic cable is embedded in the power cables for each turbine and can be accessed by a secure ISDN/broadband communications link, allowing each individual turbine to be accessed remotely over the internet. It is also therefore possible to control and monitor the turbines locally and remotely from Nova's Edinburgh office.

All important or emergency signals are sent automatically via internet and SMS to Nova engineers who can log on and monitor the devices.

Scheduled maintenance will take place in summer every 5 years, with each turbine being recovered to Kirkwall for maintenance before being redeployed at the site. All turbines will be serviced in a single operation every 5 years. Unscheduled turbine maintenance is anticipated to be required up to 2-3 times per year. The stages involved in this process are set out below.

1. **Nacelle retrieval.**

A release mechanism is activated by the service vessel using a Launch and Recovery System (LARS) recovery tool which is lowered vertically. This releases the nacelle from the base from where it is lifted to the surface, secured to the vessel and removed to Kirkwall for servicing. Temporary marker buoys may be used.

2. **Redeployment.**

On completion of servicing, the nacelle is returned to the site; the device is lowered onto the base using the LARS and the structural connection is completed. The LARS is then recovered.

Maintenance operations will be scheduled during the summer months for improved weather and daylight conditions. However Nova has experience in Shetland deploying, recovering and decommissioning devices in all seasons and during neap and spring tides, should maintenance be necessary outside of this planned schedule. Maintenance operations will be carried out during appropriately slack tides with suitable wave and weather conditions. The installation will be managed by Nova Innovation staff who will be resident in Orkney for the project. All work will be accompanied by the relevant notifications.

Nova will work with EMEC to produce a project-specific Emergency Response Cooperation Plan (ERCoP) for incorporation as an Annex to the site-wide ERCoP. This will be produced in consultation with the MCA Coastguard Operations Centre (CGOC) and SAR bodies. The ERCoP will cover the operation and maintenance phase of the OCEANSTAR Project and will include scenarios of planned and unplanned maintenance.

## 5.5 Removal and decommissioning

Following a period of 25 years, the OCEANSTAR Project will be fully decommissioned, within a 28 week period during 14 neap tides in the summer of 2052.

Once a marine licence for the OCEANSTAR Project has been issued, Marine Directorate will issue a 's.105 notice' to Nova under Section 105 of the Energy Act 2004, requiring the submission of a detailed plan for the decommissioning works accompanied by details of costs and proposed financial securities. Nova will consult on the plan with an approved set of stakeholders and make the plan available to the public. Marine Directorate will also consult on the plan before seeking ministerial approval on the scheme.

An interim Decommissioning Programme<sup>3</sup> has been produced describing the measures to decommission the OCEANSTAR Project based on best available evidence at the time of writing. This includes Nova's recent experience successfully decommissioning the three original turbines in the Shetland Tidal Array, Bluemull Sound. The level of detail provided is likely to be improved upon over time. A comprehensive Decommissioning Method Statement will be produced in support of a Marine License to decommission the OCEANSTAR at the end of the project lifetime. This will be based on best available evidence and best practice at the time.

## 5.6 Vessels

The vessels to be used for offshore operations will be determined in advance of the operation depending on availability. Only vessels on EMEC's approved list of operators will be used for offshore operations. The size and operational capability of vessels will be as follows:

1. Surveying: small local boat or Multicat vessel (see below).
2. Deployment and retrieval: Multicat vessel.

The small scale and modularity of Nova's Oceanstar turbines mean that only one multicat workboat vessel is required to carry out offshore works. Typical workboats or multicat workboats such as MV C-Odyssey as shown in Figure 7, or similar, with lengths no greater than 28m and draught up to 4m, will be used.



**Figure 7. Representative vessel that will be utilised throughout the OCEANSTAR Project (Leask Marine C-Odyssey).**

*Source: Leask Marine*

---

<sup>3</sup> Nova Innovation (2023). OCEANSTAR Project, EMEC Fall of Warness. Decommissioning Programme. December 2023.

Only one vessel will be on any work-site at any given time during the OCEANSTAR Project. A maximum of two vessels may be present in the project area, but they will be working in different areas e.g. the temporary ballast zone and the final deployment zone. The equipment deployment and recovery tasks to be carried out are of the same type that Nova has been carrying out routinely in Shetland since 2014. The local harbour master and other vessels that frequent the Fall of Warness site are familiar with these or similar operations, as are the identified vessel providers. No special vessel management arrangements are required, beyond the standard EMEC protocols.

The harbour master, Orkney Islands Council Harbour Authority and Shetland CGOC (which covers both Orkney and Shetland) will be advised in advance of all operations. All quayside and harbour works will be undertaken in compliance with the direction of the harbour master.

All vessels involved in the installation, maintenance and decommissioning of the device will comply with all aspects of the International Regulations for Preventing Collisions at Sea (COLREGS). All vessels used will carry all equipment as required under the vessels' registration, e.g. the Code of practice for the safety of small workboats and pilot boats. Notices to Mariners will be used to inform stakeholders of offshore operations.

Nova does not plan to use any ROVs or divers during operations throughout the OCEANSTAR Project. Operations are designed not to require divers or ROVs and have been conducted accordingly, on multiple occasions by Nova at the Shetland Tidal Array. Equipment deployment and recoveries will be carried out using a combination of the main vessel winch and the vessel HIAB crane, plus vertically lowered and surface-actuated recovery tools.

## 6 Consultation

EMEC carried out comprehensive consultation with navigational stakeholders, including Marine Directorate, NatureScot, Maritime and Coastguard Agency, Northern Lighthouse Board, Orkney Islands Council and the local community to inform the site-wide NRA for the Fall of Warness site (REP315) required to support the application for the Section 36 consent. EMEC conducts ongoing regular stakeholder engagement to ensure the pipeline of activity at the Fall of Warness site is well communicated and any new navigational concerns/issues are addressed as soon as possible.

Project-specific consultation for OCEANSTAR is not required since the navigational risk is low (see Section 4) and the project will be installed in line with the site-wide Section 36 consent.

## 7 Key navigational themes

In order to complete this project-specific assessment, a comprehensive review of the site-wide NRA for EMEC's Fall of Warness site was conducted. The following navigational themes have been considered during the assessment.

### 7.1 Vessel routing

The Oceanstar turbines will be located in an area identified by EMEC as suitable for non-surface piercing devices. It is anticipated that there will be limited need for vessel restrictions around the turbines, once installed, since the entire turbine structure is non-surface piercing, with a minimum surface clearance of 10 m at Lowest Astronomical Tide (LAT).



---

Nova does not anticipate that there will be any requirement for surface markers since the 10 m clearance will allow local traffic to pass over the array. In the Draft Orkney Harbours Masterplan<sup>4</sup>, Orkney Islands Council identified 10 m below Chart Datum as the depth required at harbour facilities to accommodate a range of vessels including ferries, the largest cruise ships, renewable energy, oil and gas vessels and cargo/livestock vessels. A minimum surface clearance of 10 m for turbines will therefore also allow such vessels to freely pass the array of Oceanstar turbines.

The as-installed position of the turbines will be confirmed with the UK Hydrographic Office (UKHO) so that its charts and digital products can be updated and provide accurate information to sea users. Careful micro-siting of turbines will be used, informed by discussions with navigational stakeholders, including Orkney Ferries, to ensure safe navigable channels, including during periods of poor weather.

If required, the offshore electrical hub will be marked with appropriate marking and lighting that complies with the relevant aspects of the International Regulations for Preventing Collisions at Sea COLREGS<sup>5</sup>, and the requirements of the Northern Lighthouse Board and the International Association of Marine Aids to Navigation and Lighthouse Authorities (IALA) to alert other mariners to the asset. Any floating or surface piercing component of the hub will be painted yellow and any Aids to Navigation will be visible to the mariner from all relevant directions in the horizontal plane, by day and night.

The hub will be located within the existing EMEC site boundary in a suitable site that complies with EMEC's site-wide Navigation Risk Assessment for the Fall of Warness. If the hub is a floating structure, it will likely be sited in a sheltered location, agreed with EMEC and identified as being suitable for surface piercing devices. As with turbines, careful micro-siting will be used for the offshore hub, informed by discussions with navigational stakeholders, including Orkney Ferries, to ensure safe navigable channels.

The presence of vessels during offshore operations may lead to some temporary displacement of the vessels from the area. However, Notices to Mariners and Kingfisher Bulletins will be issued in advance of any works. Before installation commences Nova will work with EMEC to produce a project-specific Emergency Response Cooperation Plan (ERCoP) for incorporation as an Annex to the site-wide ERCoP. This will be produced in consultation with the MCA Coastguard Operations Centre (CGOC) and SAR bodies.

All vessels involved in offshore works associated with the OCEANSTAR Project will be approved by EMEC and comply with all aspects of COLREGS. The vessels used will carry all equipment as required under the vessels' registration, e.g. the Code of practice for the safety of small workboats and pilot boats.

The Fall of Warness site is clear of major shipping routes and vessels currently transiting the site appear to be well aware of the deployments across the site.

## 7.2 Contact / allision risk

All Oceanstar turbines will be seabed based and non-surface piercing, with a minimum surface clearance of 10 m at LAT, so the risk of any contact or allision is negligible. In the Draft Orkney Harbours Masterplan, Orkney Islands Council identified 10 m below Chart Datum as the depth

---

<sup>4</sup> Orkney Islands Council: Orkney Harbour Authority Draft Orkney Harbours Masterplan Phase 1. Fisher Associates. June 2019. pp82.

<sup>5</sup> Convention on the International Regulations for Preventing Collisions at Sea, 1972.

---

required at harbour facilities to accommodate a range of vessels including ferries, the largest cruise ships, renewable energy, oil and gas vessels and cargo/livestock vessels.

The Oceanstar turbines will be located in an area identified by EMEC as suitable for non-surface piercing devices. The as-installed position of the turbines will be confirmed with the UK Hydrographic Office (UKHO) so that its charts and digital products can be updated and provide accurate information to sea users. Careful micro-siting of turbines will be used, informed by discussions with navigational stakeholders, including Orkney Ferries, to ensure safe navigable channels, including during periods of poor weather.

The offshore electrical hub will be marked with appropriate marking and lighting that complies with the relevant aspects of the International Regulations for Preventing Collisions at Sea COLREGS<sup>6</sup>, and the requirements of the Northern Lighthouse Board and the International Association of Marine Aids to Navigation and Lighthouse Authorities (IALA) to alert other mariners to the asset. Any floating or surface piercing component of the hub will be painted yellow and any Aids to Navigation will be visible to the mariner from all relevant directions in the horizontal plane, by day and night.

The hub will be located within the existing EMEC site boundary in a suitable site that complies with EMEC's site-wide Navigation Risk Assessment for the Fall of Warness. If the hub is a floating structure, it will likely be sited in a sheltered location, agreed with EMEC and identified as being suitable for surface piercing devices. As with turbines, careful micro-siting will be used for the offshore hub, informed by discussions with navigational stakeholders, including Orkney Ferries, to ensure safe navigable channels. The risk of any contact or allision with the electrical hub is therefore negligible.

Few vessels navigate within the Fall of Warness site and the use of appropriate marking and lighting to alert other mariners to the assets onsite will mitigate the risk of contact, if deemed necessary. No such mitigation has been required for the Shetland Tidal Array which operates next to Cullivoe a key port for the Scottish pelagic fishing industry.

The as-installed coordinates of all offshore assets associated with the OCEANSTAR Project will be provided directly to the UKHO so that its charts and products can be updated.

### **7.3 Under keel clearance**

All Oceanstar turbines will be seabed based and non-surface piercing, with a minimum under keel clearance of 10 m at LAT. In the Draft Orkney Harbours Masterplan, Orkney Islands Council identified 10 m below Chart Datum (LAT) as the depth required at harbour facilities to accommodate a range of vessels including ferries, the largest cruise ships, renewable energy, oil and gas vessels and cargo/livestock vessels. A minimum surface clearance of 10 m for turbines will therefore also allow such vessels to freely pass turbines in the array.

The Oceanstar turbines will be located in an area identified by EMEC as suitable for non-surface piercing devices. The as-installed position of the turbines will be confirmed with the UKHO so that its charts and digital products can be updated and provide accurate information to sea users. Careful micro-siting of turbines will be used, informed by discussions with navigational stakeholders, including Orkney Ferries, to ensure safe navigable channels, including during periods of poor weather. Any navigational risk associated with the turbines is therefore rendered negligible.

---

<sup>6</sup> Convention on the International Regulations for Preventing Collisions at Sea, 1972.

---

The offshore electrical hub will either be floating, fixed in place using an appropriate mooring system, or gravity-based on the seabed, but with the ability to be easily raised to the surface using temporary flotation. Any floating or surface piercing component of the hub will be painted yellow and any Aids to Navigation will be visible to the mariner from all relevant directions in the horizontal plane, by day and night. Appropriate marking and lighting will be utilized to alert other mariners to the offshore electrical hub. All marking and lighting will comply with the relevant aspects of COLREGS, and the requirements of the Northern Lighthouse Board and IALA, as appropriate.

The hub will be located within the existing EMEC site boundary in a suitable site that complies with EMEC's site-wide Navigation Risk Assessment for the Fall of Warness. If the hub is a floating structure, it will likely be sited in a sheltered location, agreed with EMEC and identified as being suitable for surface piercing devices. Careful micro-siting will be used for all project infrastructure, informed by discussions with navigational stakeholders, including Orkney Ferries, to ensure safe navigable channels.

#### **7.4 Collision risk and visual navigation**

The turbines in the OCEANSTAR Project will not present a collision risk or hindrance to visual navigation since they will be seabed based and non-surface piercing, with a minimum clearance of 10 m. In the Draft Orkney Harbours Masterplan, Orkney Islands Council identified 10 m below Chart Datum as the depth required at harbour facilities to accommodate a range of vessels including ferries, the largest cruise ships, renewable energy, oil and gas vessels and cargo/livestock vessels.

The turbines will be located in an area identified by EMEC as suitable for non-surface piercing devices. The as-installed position of the turbines will be confirmed with UKHO so that its charts and digital products can be updated and provide accurate information to sea users. Careful micro-siting of turbines will be used, informed by discussions with navigational stakeholders, including Orkney Ferries, to ensure safe navigable channels, including during periods of poor weather.

The offshore electrical hub will either be floating, fixed in place using an appropriate mooring system, or gravity-based on the seabed, but with the ability to be easily raised to the surface using temporary flotation. Any floating or surface piercing component of the hub will be painted yellow and any Aids to Navigation will be visible to the mariner from all relevant directions in the horizontal plane, by day and night. Appropriate marking and lighting will be utilized to alert other mariners to the offshore electrical hub. All marking and lighting will comply with the relevant aspects of COLREGS, and the requirements of the Northern Lighthouse Board and IALA, as appropriate.

#### **7.5 Communication, radar and positioning system**

The scale of the assets to be installed during this project are not likely to impact on electronic communication or positioning systems.

#### **7.6 Moorings and buoys**

No permanent moorings will be required for the Oceanstar turbines since they will be gravity-based using appropriately calculated ballast. This approach has been used successfully at the Shetland Tidal Array for more than 8 years.

The offshore electrical hub will either be gravity-based on the seabed with the ability to be easily raised to the surface using temporary flotation, or floating and fixed in place using an appropriate gravity-based mooring or anchoring system. All hub moorings or buoys will comply with the

---

relevant aspects of COLREGS and the requirements of the Northern Lighthouse Board and IALA, as appropriate.

Any temporary moorings or buoys used during offshore works will also comply with the relevant aspects of COLREGS or Northern Lighthouse Board/IALA requirements as appropriate.

## **7.7 Station keeping**

All offshore assets in the Shetland Tidal Array have remained in their as-installed positions on the seabed in Bluemull Sound. Any loss of station would be detected by Nova's remote turbine analytics system.

All Oceanstar turbine components, including turbine nacelles and rotors will be negatively buoyant (as is the case for the Shetland Tidal Array). The risk of collision between part, or all, of any detached asset and other sea users or structures is therefore negligible.

Full details of any loss of station or detached objects would be shared immediately with EMEC, the Maritime and Coastguard Agency, local Coastguard, Marine Directorate and other navigational stakeholders. Full details on reporting and response procedures will be provided in a project-specific Emergency Response Cooperation Plan (ERCoP), which Nova will produce before installation commences, in consultation with the MCA Coastguard Operations Centre (CGOC) and Search and Rescue (SAR) bodies.

## **7.8 Fishing activity**

Relatively little fishing takes place in the Fall of Warness area and fishermen would generally be expected to take precautions to avoid any underwater assets that may be present across the area.

## **7.9 Recreational activity**

There is no racing or small boat sailing at the Fall of Warness site, most recreational vessels are yachts on passage.

## **7.10 Subsea cables**

Intra-array cables will be used to connect the turbines with the offshore electrical hub, which will connect to export cable(s) that are connected to EMEC's onshore substation. The cables will be laid on the seabed, with protection where necessary. All cables will consist of a number of copper conductors and optical fibres, protected by a double armour layer and HDPE sheath. The double wire armouring has been proven to provide stable under its own weight on the seabed at Nova's Shetland Tidal Array in Bluemull Sound, Shetland.

The intra-array cables will be located away from currently installed subsea cables at the Fall of Warness site to avoid spatial overlap or complications during installation. Relatively little fishing takes place in or around the proposed location of the OCEANSTAR Project at the Fall of Warness site. Fishermen would generally be expected to take precautions to avoid any underwater assets that may be present across the area, so the risk of snagging is negligible.

Similarly, there is no racing or small boat sailing at the Fall of Warness site, so most recreational vessels are yachts on passage. Recreational and other vessels would generally be expected to take precautions to avoid dropping anchor on or around any underwater assets that may be present across the area, so the risk of snagging is negligible.

There is no evidence of anchoring or gear snagging at Fall of Warness historically.

## 7.11 Search and rescue

The turbines in the OCEANSTAR Project will be fully submerged, while the offshore electrical hub will be very small scale. OCEANSTAR Project infrastructure will therefore not have any impact on electronic communication or positioning systems, nor impact search and rescue (SAR) capabilities. Before installation commences Nova will work with EMEC to produce a project-specific Emergency Response Cooperation Plan (ERCoP) for incorporation as an Annex to the site-wide ERCoP. This will be produced in consultation with the MCA Coastguard Operations Centre (CGOC) and SAR bodies.

## 7.12 Cumulative and in-combination

No navigational issues are expected as result of the OCEANSTAR Project in combination with nearby projects, including other berths within the Fall of Warness site.

# 8 Risk controls

## 8.1 Site-wide risk controls

A number of risk controls are embedded by the processes EMEC has implemented in order to operate the site and the layout of the Fall of Warness site. The embedded risk control measures are detailed in Table 4, with any project-specific actions including any divergence from the specified control discussed.

**Table 4. EMEC embedded risk controls for Fall of Warness site.**

ID	Embedded risk control	Description	Project-specific actions
1.	PPE Requirement	Maintenance teams to wear suitable PPE when working on the assets, including life jackets.	The requirement for appropriate PPE is included in Nova and contractor RAMS.
2.	Training of staff	Staff to be trained to the required standards for their work and have suitable local knowledge of regulations and operations in the Orkney Islands.	All personnel engaged in offshore operations will be up to date in relevant H&S training and certification.
3.	Emergency Response and Cooperation Plan (ERCoP)	ERCoP for site developed and agreed with the MCA and SAR bodies to be consulted.	Before installation commences Nova will work with EMEC to produce a project-specific ERCoP for incorporation as an Annex to the site-wide ERCoP.

ID	Embedded risk control	Description	Project-specific actions
4.	Notices to Mariners (NtM) and Promulgation	In addition to NtM, EMEC's Maritime Safety Information Standard Operating Procedures (SOP) ensures that all key navigational consultees are informed prior to any works. Distribution could include HMCG, Orkney Harbours (available via Orkney Islands Council Marine Services website), Orkney Marina noticeboards (as necessary), Orkney Fisheries Association, Scottish Fisheries Federation and UKHO. Stakeholders are targeted with information about relevant assets based on their activities and location.	Kingfisher Bulletins will be issued prior to all offshore works.  NtM will be sent direct to all relevant navigational stakeholders in advance of offshore works.  Nova will produce and maintain a navigational stakeholder contact database for NtM.
5.	Incident monitoring and reporting	EMEC to encourage incident/near miss reporting and monitor any safety issues at the test site. If necessary, risk control to be reviewed. Risk assessments to be reviewed following any incidents.	Nova will report incidents to EMEC, MCA, local Coastguard, Marine Directorate and other navigational stakeholders as appropriate.
6.	EMEC Procedures	EMEC has a number of SOPs and standards in place to reduce navigation risks, such as: <ul style="list-style-type: none"> <li>• Task risk assessment;</li> <li>• Control of work (permit to access)</li> <li>• Hazard identification reporting; and</li> <li>• Maritime safety information.</li> </ul>	Nova will comply with the requirements of EMEC's site-wide SOPs and ERPs.  Any project-specific operational procedures will comply with EMEC's SOPs and standards.
7.	Hydrography	Contractual responsibility for developer to return the site to the original condition post-decommissioning.	The site will be returned to the original condition post-decommissioning. This will be confirmed by a post-decommissioning survey.
8.	Charting	Site is marked on nautical charts including a chart note.	As-installed coordinates of all offshore assets will be provided directly to UKHO so its charts and products can be updated.
9.	Site Monitoring	EMEC's SCADA system provides real-time status information, trends, alarms and remote-control access to facilitate a safe working environment, comprehensive assessment and safe operation of the sites.	N/A

ID	Embedded risk control	Description	Project-specific actions
10.	CCTV	Fall of Warness site is monitored by CCTV, located at Caldale, EMEC's onshore substation, to satisfy operational requirements for control and monitoring of site activities, visual checks of the site environment, monitoring of lone worker safety, effective plant operation and substation security.	N/A
11.	Liaison with local stakeholders	EMEC regularly liaises with key local stakeholders to identify any potential issues as soon as possible. Regular updates include information regarding upcoming deployments and significant operations at the site.	Nova will provide information to and assist with EMEC liaison as appropriate.
12.	500m advisory ATBA	A 500m advisory ATBA exists around all devices located at the Fall of Warness site.	N/A

## 8.2 Project-specific risk controls

Table 5 provides a description of the additional project-specific risk controls that will be implemented for the OCEANSTAR Project.

**Table 5. OCEANSTAR Project-specific risk controls.**

ID	Project-specific risk control	Description
1.	Heightened monitoring in adverse metocean conditions	During gale force winds, periodic monitoring of the assets is recommended to ensure excessive forces are not acting on the moorings which might cause a breakout.
2.	Inspection and maintenance programme	Nova will carry out surveillance of offshore assets using its remote turbine analytics system. Maintenance will also be carried out as appropriate to check the asset, its fittings and any signs of wear and tear. If a floating electrical hub is used, it will be inspected regularly, to identify any failings which might result in a mooring failure and breakout.
3.	Remote shut down or braking	Devices can be shut down or slowed remotely from Nova's turbine control centre to allow access or prevent contact with a vessel.
4.	Micro-siting	The offshore electrical hub will either be floating, fixed in place using an appropriate mooring system, or gravity-based on the seabed, but with the ability to be easily raised to the surface using temporary flotation. The hub will be located within the existing EMEC site boundary in a suitable site that complies with EMEC's site-wide Navigation Risk Assessment for the Fall of Warness. If the hub is a floating structure, it will likely be sited in a sheltered location, agreed with EMEC and identified as being suitable for surface piercing devices. Careful micro-siting will be used for all project infrastructure, informed by discussions with navigational stakeholders, including Orkney Ferries, to ensure safe navigable channels.

ID	Project-specific risk control	Description
5.	Marking and Lighting	<p>The offshore electrical hub will either be floating, fixed in place using an appropriate mooring system, or gravity-based on the seabed, but with the ability to be easily raised to the surface using temporary flotation.</p> <p>Any surface piercing components of the hub will be lit to the requirements of NLB and marked in line with IALA guidance, IALA Recommendation O-139 (2013). Marking and lighting is likely to include:</p> <ul style="list-style-type: none"> <li>- Yellow day marking/painting above the waterline.</li> <li>- A flashing yellow special mark light (Category 1) with a nominal range of not less than 2 nautical miles.</li> <li>- Any Aids to Navigation that are visible to the mariner from all relevant directions in the horizontal plane, by day and night.</li> </ul> <p>If floating or in shallow water, the hub may be marked as either an isolated danger mark or a special mark. Nova anticipates that appropriate statutory sanctions will be in place to exhibit, alter or discontinue lighting.</p>
6.	Liaison with local stakeholders	<p>Consultation will be undertaken with Orkney Marine Services, the MCA and NLB prior to construction phase to confirm that adequate risk controls are in place.</p> <p>EMEC also conducts regular stakeholder consultation events to ensure that local marine users are aware of the pipeline of activity.</p>
7.	Installation, maintenance and removal	<p>All vessels undertaking activities on site will be approved by EMEC and comply with EMEC standard operating procedures. Vessels should be mindful of other navigating vessels and avoid disrupting the activities of others.</p>
8.	Project-specific ERCoP	<p>Before installation commences Nova will work with EMEC to produce a project-specific ERCoP for incorporation as an Annex to the site-wide ERCoP. This will be produced in consultation with the MCA Coastguard Operations Centre (CGOC) and SAR bodies.</p>

## 9 Summary and conclusion

Navigational issues associated with turbines in the OCEANSTAR Project once installed will be negligible, since the entire Oceanstar turbine structure will be non-surface piercing, with a minimum surface clearance of 10 m at Lowest Astronomical Tide (LAT). The turbines will be located in an area identified by EMEC as suitable for non-surface piercing devices. The as-installed position of the turbines will be confirmed with the UK Hydrographic Office (UKHO) so that its charts and digital products can be updated and provide accurate information to sea users. Careful micro-siting of turbines will be used, informed by discussions with navigational stakeholders, including Orkney Ferries, to ensure safe navigable channels, including during periods of poor weather.

If required, the offshore electrical hub will be marked with appropriate marking and lighting that complies with the relevant aspects of the International Regulations for Preventing Collisions at Sea COLREGS<sup>7</sup>, and the requirements of the Northern Lighthouse Board and the International Association of Marine Aids to Navigation and Lighthouse Authorities (IALA) to alert other mariners to the asset. Any floating or surface piercing component of the hub will be painted yellow and any

<sup>7</sup> Convention on the International Regulations for Preventing Collisions at Sea, 1972.



---

Aids to Navigation will be visible to the mariner from all relevant directions in the horizontal plane, by day and night.

The hub will be located within the existing EMEC site boundary in a suitable site that complies with EMEC's site-wide Navigation Risk Assessment for the Fall of Warness. If the hub is a floating structure, it will likely be sited in a sheltered location, agreed with EMEC and identified as being suitable for surface piercing devices. Careful micro-siting will be used for all project infrastructure, informed by discussions with navigational stakeholders, including Orkney Ferries, to ensure safe navigable channels.

The presence of vessels during offshore operations may lead to some temporary displacement of the vessels from the area. However, Notices to Mariners and Kingfisher Bulletins will be issued in advance of works.

Before installation commences Nova will work with EMEC to produce a project-specific ERCoP for incorporation as an Annex to the site-wide ERCoP. This will be produced in consultation with the MCA Coastguard Operations Centre (CGOC) and SAR bodies.

The OCEANSTAR Project will be implemented under EMEC's site-wide licence issued by Marine Scotland (operational name) on behalf of Scottish Ministers under Section 36 of the Electricity Act 1989 for the Fall of Warness. **EMEC and Nova will work together to manage installation of OCEANSTAR Project offshore infrastructure and associated activity to ensure that the project is installed and operates in accordance with site-wide consents. The total number of devices (or any other parameter) will not breach any limit in the overarching section 36 consent for Fall of Warness.**