

# Neart na Gaoithe Offshore Wind Farm

Construction Programme and Construction Method Statement

Revision 9.0

May 2024

DOCUMENT REFERENCE: NNG-NNG-ECF-PLN-0002

## Neart na Gaoithe Offshore Wind Farm Construction Programme and Construction Method Statement

Pursuant to Section 36 Condition 9 and Marine Licence (Offshore Transmission Works) Condition 3.2.2.13 in respect of the Construction Programme; and Section 36 Consent Condition 10, the Marine Licence (Generating Station) Condition 3.2.2.8 and Marine Licence (Offshore Transmission Works) Conditions 3.2.2.7 in respect of the Construction Method Statement

For the approval of the Scottish Ministers

SIGN OFF					
Name (Role)		Signature		Date	
David Sweenie NnGOWL Development Manager				0305/2024	
Michelle Elliott NnGOWL Offshore Consents Support				17/04/2024	
Robert MacKintosh Environmental Clerk of Works				17/04/2024	
DOCUMENT CONTROL					
Document Number		NNG-NNG-ECF-PLN-0002			
Document Title		Construction Programme and Construction Method Statement			
Re v.	Date	Description	Prepared	Checked	Approved
01	04 SEP 2019	First version for consultation and approval by Scottish Ministers	SMA	EWA	DSW
02	09 DEC 2019	Second version to include project updates	SMA	EWA	DSW
03	23 JUL 2020	Third version to include project updates	SMA	CGI	DSW

04	15 JUL 2021	Update to Section 4 to reflect inter-array pre-lay trenching campaign	SMA	CGI	DSW
05	12 MAY 2022	Change to Section 4 and 6.4 to update programme and vessel types	SMA	CGI	DSW
06	17 AUG 2022	Change to Section 4 to update programme	SMA	CGI	DSW
07	22 FEB 2023	Change to Section 4 to update programme	SMA	MEL	JPE
08	21 NOV 2023	Change to Section 4 to update programme and Section 8.1 update to the construction programme in relation to the EIAR construction dates	RMA	MEL	DSW
09	3 May 2024	Change to Section 4 to update programme and Section 8.1 update to the construction programme in relation to the EIAR construction dates	RMA	MEL	DSW

## Overview

### Purpose and Objectives of the Plan

This Construction Programme (CoP) and Construction Method Statement (CMS) document has been prepared to address the specific requirements of the relevant conditions attached to the Section 36 (S36) consent and Marine Licences (collectively referred to as the Offshore Consents) issued to Neart na Gaoithe Offshore Windfarm Limited (NnGOWL).

The overall aim of the CoP is to set out the intended construction programme for the Project (Neart na Gaoithe Offshore Wind Farm and Offshore Transmission Works).

The overall aim of the CMS is to set out construction procedures and good working practices in relation to the installation of Project infrastructure.

The CoP and CMS confirms that the construction programme and procedures to be employed align with those considered in the original Application, and that construction-related mitigation measures detailed in the Application will be applied during installation.

All NnGOWL personnel and Contractors involved in the Project must comply with this CoP and CMS.

### Scope of the Plan

The CoP section of this document provides information on the following:

- The proposed dates for commencement of construction;
- The proposed details of mobilisation of plant and delivery of materials;
- The proposed dates, durations and sequencing of construction work for all key elements of the Development (highlighting contingency planning for poor weather or other delays);
- The scheduled date for final commissioning of the Project; and
- Confirmation that the construction programme dates described within the CoP align with those considered in the Application.

The CMS section of this document provides information on the following:

- Construction procedures in relation to piled foundations, jackets, wind turbines, Offshore Substation Platforms (OSPs) and inter-array, interconnector and export cables;
- Good working practices to be employed during construction;
- Identification of main contractors involved in construction;
- The roles and responsibilities of key Project personnel and contractors during construction with respect to environmental management; and
- Confirmation that the construction methods described within the CMS align with those considered in the original Application.

## Structure of the Plan

The CoP and CMS is structured as follows:

Sections 1 to 3 set out the scope and objectives of the CoP and CMS, provide an overview of the Project, and set out broad statements of compliance.

Section 4 provides detail on the construction programme.

Section 5 sets out roles and responsibilities of all personnel involved in construction.

Section 6 provides detail around construction methods, describing the equipment to be utilised and sequencing of installation works.

Section 7 presents the good working practices to be applied by NnGOWL and Contractors during construction.

Section 8 demonstrates compliance with the original Application.

## Plan Audience

This CoP and CMS document is intended to be referred to by personnel involved in the construction of the Project, including NnGOWL personnel and Contractors. All method statements and work plans produced in relation to the Project must comply with this CoP and CMS.

Compliance with this CoP and CMS will be monitored by the NnGOWL Consents Team, the NnGOWL Environmental Clerk of Works (ECoW), and the Marine Directorate Licensing Operations Team (MD-LOT).

## Plan Locations

Copies of this CoP and CMS are to be held in the following locations:

- NnGOWL Project Office;
- At the premises of any agent or Contractor acting on behalf of NnGOWL;
- All site offices dealing with marine operations including the NnGOWL Marine Coordination Centre; and
- With NnGOWL's ECoW.

# Contents

1	Introduction .....	14
1.1	Background.....	14
1.2	Objectives of this Plan .....	14
1.3	Linkages with other Consent Plans.....	17
1.4	Structure of the Plan .....	18
2	NnGOWL Statements of Compliance .....	20
2.1	Introduction.....	20
2.2	Overarching Statements of Compliance.....	20
2.3	Health and Safety, and Environmental Management .....	20
2.4	Equipment and Materials .....	20
2.5	Construction Personnel – Training and Competence .....	21
2.6	Construction Vessels .....	21
2.7	Good Working Practices .....	21
3	Project Overview.....	22
4	Construction Programme.....	24
4.1	Introduction.....	24
4.2	Key Milestone Dates.....	24
4.3	Wind Farm Construction Programme.....	25
4.4	Offshore Transmission Works Construction Programme .....	29
5	Construction Roles and Responsibilities .....	32
5.1	Introduction.....	32
5.2	NnGOWL Roles and Responsibilities .....	32
5.3	Contractors.....	33
5.4	Subcontractors .....	34
6	Construction Methods and Procedures .....	35
6.1	Introduction.....	35
6.2	Overview of the Project Construction Process .....	35
6.3	Seabed Preparation .....	37
6.4	Pile Foundations and Jacket Installation .....	37
6.5	Offshore Inter Array and Interconnector Cable Installation.....	44
6.6	Offshore Export Cable Installation.....	48
6.7	Offshore Substation Platforms .....	51
6.8	Wind Turbine Generator Installation .....	52
6.9	Wind Farm Electrical Connection and Commissioning .....	56
7	Good Working Practices.....	58

7.1	Introduction.....	58
7.2	Offshore renewable industry good working guidance .....	58
7.3	Construction management procedures.....	60
7.4	Environmental management measures .....	61
7.5	Project-specific good working practices .....	61
8	Compliance with the Application .....	64
8.1	Introduction.....	64
8.2	Compliance with the Indicative Construction Programme Assessed in the Application and Supporting Information.....	64
8.3	Compliance with the Construction Methods Assessed in the Application and Supporting Information.....	65
8.4	Delivery of Construction-related Mitigation Proposed in the Application and Supporting Information.....	72

## Figures

Figure 3-1: Wind Farm Area and Offshore Export Cable Corridor locations .....	23
Figure 4-1: Construction Programme .....	27
Figure 5-1: NnGOWL organisational structure .....	32
Figure 6-1: Overview of the Wind Farm and OfTW installation process .....	36
Figure 6-2: Foundation and jacket substructure installation sequence.....	39
Figure 6-3: Illustration of the SST .....	40
Figure 6-4: Illustration of drilling operations .....	41
Figure 6-5: Pile cleaning tool .....	42
Figure 6-6: Deployment of the jacket from the SSCV .....	43
Figure 6-7: Offshore inter-array and interconnector cable installation sequence .....	45
Figure 6-8: Example hybrid cable trenching tool.....	47
Figure 6-9: Export Cable installation sequence .....	48
Figure 6-10: Illustration of landfall cable pull-in operations.....	50
Figure 6-11: OSP installation sequence .....	52
Figure 6-12: Wind turbine installation sequence .....	54
Figure 8-1: Current offshore Construction Programme detailed within this CoP and CMS (dark blue) compared with the indicative offshore construction programme presented in the EIA Report (light blue). Hatched areas represent overlap between the two construction programmes .....	64
Figure 8-2: Comparison of support structures (foundation) installation methods described in the Application and the CMS.....	66
Figure 8-3: Comparison of jacket substructure installation methods described in the EIA Report and the Addendum and the CMS..	67
Figure 8-4: Comparison of inter-array and interconnector cable installation methods described in the EIA Report and the Addendum and the CMS .....	68
Figure 8-5: Comparison of turbine installation methods described in the EIA Report and the Addendum and the CMS .....	69
Figure 8-6: Comparison of the offshore substation topside installation described in the EIA Report and the Addendum and the CMS .....	70

Figure 8-7: Comparison of Offshore Export Cable installation methods described in the EIA Report and the Addendum and the CMS .....71

## Tables

Table 1-1: CoP and CMS consent conditions to be discharged by this Consent Plan .....14

Table 1-2: CoP and CMS linkages with other relevant Consent Plans (and consents conditions) .....17

Table 1-3 :CoP and CMS document structure.....19

Table 4-1: Summary of key milestone dates.....24

Table 5-1: NnGOWL roles and responsibilities .....32

Table 5-2: Key contractor roles and responsibilities.....33

Table 6-1: Summary of foundation components to be deposited or installed .....38

Table 6-2: Offshore Inter Array and Interconnector Cable specifications .....44

Table 6-3: Summary of offshore Export Cable components .....48

Table 6-4: Summary of Offshore Substation Platform topsides to be deposited or installed. ....51

Table 6-5: Summary of wind turbine components to be deposited or installed. ....53

Table 7-1: Offshore wind good working practice guidance .....59

Table 8-1: Construction related mitigation measures relevant to the CoP and CMS. ....72



## Acronyms and Abbreviations

TERM	DESCRIPTION
AC	Alternating Current
CDM Regulations	Construction (Design and Management) Regulations 2015
CLV	Cable Lay Vessel
COSHH	Control of Substances Hazardous to Health
CPS	Cable Protection System
CTV	Crew Transfer Vessel
DP	Dynamic Positioning
DSV	Dive Support Vessel
ECoW	Environmental Clerk of Works
EU	European Union
FID	Final Investment Decision
FP	Forth Ports
HDD	Horizontal Directional Drilling
HLV	Heavy Lift Vessel
HSE	Health, Safety and Environment
HTV	Heavy Transport Vessel
HV	High Voltage
H&S	Health and Safety
ILT	Internal Lifting Tool
JUV	Jack Up Vessels
MCA	Maritime and Coastguard Agency
MHWS	Mean High Water Spring
MLWS	Mean Low Water Spring
MD-LOT	Marine Directorate Licensing Operations Team

TERM	DESCRIPTION
NLB	Northern Lighthouse Board
NnGOWL	Neart na Gaoithe Offshore Windfarm Limited
NOTAM	Notice to Airmen
NtM	Notice to Mariners
OCV	Offshore Construction Vessel
OSP	Offshore Substation Platform
PLGR	Pre-Lay Grapple Run
ROV	Remote Operated Vehicle
RSPB	Royal Society for the Protection of Birds
SEPA	Scottish Environmental Protection Agency
SNH	Scottish Natural Heritage (now NatureScot)
SPEN	Scottish Power Energy Networks
SSCV	Semi-Submersible Crane Vessel
SST	Subsea Template
UKHO	United Kingdom Hydrographic Office
WTG	Wind Turbine Generator
XLPE	Cross-linked Polyethylene

## Defined Terms

TERM	DESCRIPTION
<b>Addendum</b>	The Addendum of Additional Information submitted to the Scottish Ministers by NnGOWL on 26 July 2018.
<b>Application</b>	The Environmental Impact Assessment Report, Habitats Regulations Appraisal Report and supporting documents submitted to the Scottish Ministers by NnGOWL on 16 March 2018; the Addendum of Additional Information submitted to the Scottish Ministers by NnGOWL on 26 July 2018 and the Section 36 Consent Variation Report dated 08 January 2019.
<b>Company</b>	Neart na Gaoithe Offshore Wind Limited (NnGOWL) (Company Number SC356223).
<b>Consent Conditions</b>	The terms that are imposed on the Company under the Offshore Consents that must be complied with.
<b>Consent Plans</b>	The plans, programmes or strategies required to be approved by the Scottish Ministers (in consultation with appropriate stakeholders) in order to discharge the Consent Conditions.
<b>Contractors</b>	Any Contractor/Supplier (individual or firm) working on the Project.
<b>EIA Report</b>	The Environmental Impact Assessment Report, dated March 2018, submitted to the Scottish Ministers by NnGOWL as part of the Application.
<b>Inter-array Cables</b>	The offshore cables connecting the wind turbines to one another and to the OSPs.
<b>Interconnector Cables</b>	The offshore cables connecting the OSPs to one another.
<b>Marine Licences</b>	The written consents granted by the Scottish Ministers under the Marine (Scotland) Act 2010, for construction works and deposits of substances or objects in the Scottish Marine Area in relation to the Wind Farm (Licence Number 06677/19/0) and The OfTW Marine Licence that was varied initially by the issue of Marine Licence MS-00008954 on the 12 October 2020, followed by issue of MS-00009466 on the 15 October 2021 and again on 26 May 2022 by issue of MS-00009831.
<b>Offshore Consents</b>	The Section 36 Consent and the Marine Licences.
<b>Offshore Export Cable Corridor</b>	The area within which the offshore export cables are to be located.
<b>Offshore Export Cables</b>	The offshore export cables connecting the OSPs to the landfall site.
<b>OfTW</b>	The Offshore Transmission Works comprising the OSPs, offshore interconnector cables and offshore export cables required to connect the Wind Farm to the Onshore Transmission Works at the landfall.
<b>OfTW Area</b>	The area outlined in red and blue in Figure 1 attached to Part 4 of the OfTW Marine Licence.
<b>OnTW</b>	The onshore transmission works from landfall and above Mean High Water Springs, consisting of onshore export cables and the onshore substation.
<b>Project</b>	The Wind Farm and the OfTW.

TERM	DESCRIPTION
<b>Section 36 Consent</b>	The written consent granted on 3 December 2018 by the Scottish Ministers under Section 36 of The Electricity Act 1989 to construct and operate the Wind Farm, as varied by the Scottish Ministers under section 36C of the Electricity Act 1989 on 4 June 2019.
<b>Section 36 Consent Variation Report</b>	The Section 36 Consent Variation Report submitted to the Scottish Ministers by NnGOWL as part of the Application as defined above on 08 January 2019.
<b>Subcontractors</b>	Any Contractor/Supplier (individual or firm) providing services to the Project, hired by the Contractors (not NnGOWL).
<b>Wind Farm</b>	The offshore array as assessed in the Application including wind turbines, their foundations and inter-array cabling.
<b>Wind Farm Area</b>	The area outlined in black in Figure 1 attached to the Section 36 Consent Annex 1, and the area outlined in red in Figure 1 attached to Part 4 of the Wind Farm Marine Licence.

## Consent Plans

CONSENT PLAN	ABBREVIATION	DOCUMENT REFERENCE NUMBER
Decommissioning Programme	DP	NNG-NNG-ECF-PLN-0016
Construction Programme and Construction Method Statement	CoP & CMS	NNG-NNG-ECF-PLN-0002
Development Specification and Layout Plan	DSLDP	NNG-NNG-ECF-PLN-0003
Design Statement	DS	NNG-NNG-ECF-PLN-0004
Offshore Written Scheme of Investigation and Protocol for Archaeological Discoveries	WSI & PAD	NNG-NNG-ECF-PLN-0005
Environmental Management Plan	EMP	NNG-NNG-ECF-PLN-0006
Cable Plan	CaP	NNG-NNG-ECF-PLN-0007
Fisheries Management and Mitigation Strategy	FMMS	NNG-NNG-ECF-PLN-0008
Lighting and Marking Plan	LMP	NNG-NNG-ECF-PLN-0009
Navigational Safety and Vessel Management Plan	NSVMP	NNG-NNG-ECF-PLN-0010
Piling Strategy	PS	NNG-NNG-ECF-PLN-0011
Operation and Maintenance Programme	OMP	NNG-NNG-ECF-PLN-0012
Project Environmental Monitoring Programme	PEMP	NNG-NNG-ECF-PLN-0013
Construction Traffic Management Plan	CTMP	NNG-NNG-ECF-PLN-0014
Emergency Response Cooperation Plan	ERCoP	NNG-NNG-ECF-PLN-0015

# 1 Introduction

## 1.1 Background

1. The Neart na Gaoithe Offshore Wind Farm (Revised Design) received consent under Section 36 of the Electricity Act 1989 from the Scottish Ministers on 03 December 2018 and was granted two Marine Licences by the Scottish Ministers, for the Wind Farm and the associated Offshore Transmission Works (OfTW), on 03 December 2018. The S36 consent and Wind Farm Marine Licences were revised by issue of a variation to the S36 Consent and Marine Licence 06677/19/0 on 04 June 2019. The OfTW Marine Licence was varied initially by the issue of Marine Licence MS-00008954 on the 12 October 2020, followed by issue of MS-00009466 on the 15 October 2021 and again on 26 May 2022 by issue of MS-00009831. The revised S36 Consent and associated Marine Licences are collectively referred to as ‘the Offshore Consents’.
2. The Project is being developed by Neart na Gaoithe Offshore Wind Limited (NnGOWL).

## 1.2 Objectives of this Plan

3. The Offshore Consents contain a variety of conditions that must be discharged through approval by the Scottish Ministers prior to the commencement of any offshore construction works. Two such requirements are the approval of a Construction Programme (CoP) and a Construction Method Statement (CMS). The relevant conditions setting out the requirement for a CoP and a CMS, and which are to be discharged by this combined CoP and CMS, are presented in full in Table 1-1.
4. This CoP and CMS is intended to satisfy the requirements of the S36 Consent and Marine Licence conditions to allow the complete discharge of the relevant conditions attached to the Offshore Consents.

Table 1-1: CoP and CMS consent conditions to be discharged by this Consent Plan

OFFSHORE CONSENTS REFERENCE	CONDITION	WHERE ADDRESSED
Section 36 Consent Condition 9	The Company must, no later than six months prior to the Commencement of the Development, submit a Construction Programme (“CoP”), in writing, to the Scottish Ministers for their written approval.	This document sets out the CoP for approval by Scottish Ministers
	Such approval may only be granted following consultation by the Scottish Ministers with Scottish Natural Heritage (“SNH”), Scottish Environment Protection Agency (“SEPA”), Maritime and Coastguard Agency (“MCA”), Northern Lighthouse Board (“NLB”), Royal Society for the Protection of Birds Scotland (“RSPB Scotland”), Angus Council, Dundee City Council, East Lothian Council, Fife Council, Scottish Borders Council and any such other advisors or organisations as may be required at the discretion of the Scottish Ministers.	Consultation to be undertaken by the Scottish Ministers
	The CoP must set out: The proposed date for Commencement of Development;	Table 4-1, Section 4.2 and Section 4.3
	The proposed timings for mobilisation of plant and delivery of materials, including details of onshore lay-down areas;	Table 4-1, Section 4.2 and Section 4.3

OFFSHORE CONSENTS REFERENCE	CONDITION	WHERE ADDRESSED
	The proposed timings and sequencing of construction work for all elements of the Development infrastructure;	Table 4-1, Section 4.2 and Section 4.3
	Contingency planning for poor weather or other unforeseen delays;	Section 4.3
	The scheduled date for Final Commissioning of the Development.	Section 4.3
<b>OftW Marine Licence Condition 3.2.2.13</b>	The Licensee must, no later than six months prior to the Commencement of the Works, submit a CoP, in writing, to the Licensing Authority for its written approval.	This document sets out the CoP for approval by Scottish Ministers
	Such approval may only be granted following consultation by the Licensing Authority with SNH, SEPA, MCA, NLB, RSPB Scotland, Angus Council, Dundee City Council, East Lothian Council, Fife Council, Scottish Borders Council and any such other advisors or organisations as may be required at the discretion of the Licensing Authority.	Consultation to be undertaken by the Scottish Ministers
	The CoP must set out: The proposed date for Commencement of the Works;	Section 4.4
	The proposed timings for mobilisation of plant and delivery of materials, including details of onshore lay-down areas;	Section 4.4
	The proposed timings and sequencing of construction work for all elements of the Works infrastructure;	Section 4.4
	Contingency planning for poor weather or other unforeseen delays; and	Section 4.4
	The scheduled date for Completion of the Works.	Section 4.4
<b>Section 36 Consent Condition 10</b>	The Company must, no later than 6 months prior to the Commencement of the Development [Wind Farm] submit a Construction Method Statement ("CMS"), in writing, to the Scottish Ministers for their written approval.	This document sets out the CMS for approval by Scottish Ministers
	Such approval may only be granted following consultation by the Scottish Ministers with SNH, SEPA, MCA, NLB, RSPB Scotland, Forth Ports ("FP"), Angus Council, Dundee City Council, East Lothian Council, Fife Council, Scottish Borders Council and any such other advisors or organisations as may be required at the discretion of the Scottish Ministers.	Consultation to be undertaken by the Scottish Ministers
	The CMS must include, but not be limited to: a) Details of the commencement dates, duration and phasing for the key elements of construction, the working areas,	Section 4.3 and Section 7

OFFSHORE CONSENTS REFERENCE	CONDITION	WHERE ADDRESSED
	the construction procedures and good working practices for installing the Development.	
	b) Details of the roles and responsibilities, chain of command and contact details of company personnel, any contractors or sub-contractors involved during the construction of the Development.	Section 5  Note, contact details are not detailed within Section 5. NnGOWL will collate key personnel contact details into a Project Contact Register. This will be provided to MD-LOT separately once finalised and prior to Construction.
	c) Details of how the construction related mitigation steps proposed in the Application are to be delivered.	Section 8.4
	The CMS must adhere to the construction methods assessed in the Application.	Section 6 and 8
	The CMS also must, so far as is reasonably practicable, be consistent with the Design Statement (“DS”), the Environmental Management Plan (“EMP”), the Vessel Management Plan (“VMP”), the Navigational Safety Plan (“NSP”), the Piling Strategy (“PS”), the Cable Plan (“CaP”) and the Lighting and Marking Plan (“LMP”).	Section 1.3
<b>Wind Farm Marine Licence Condition 3.2.2.8 and OfTW Marine Licence Condition 3.2.2.7</b>	The Licensee must, no later than 6 months prior to the Commencement of the Works submit a CMS, in writing, to the Licensing Authority for their written approval.	This document sets out the CMS for approval by Scottish Ministers
	Such approval may only be granted following consultation by the Licensing Authority with SNH, SEPA, MCA, NLB, RSPB Scotland, Forth Ports Angus Council, Dundee City Council, East Lothian Council, Fife Council, Scottish Borders Council and any such other advisors or organisations as may be required at the discretion of the Licensing Authority. Commencement of the Works may not take place until such approval is granted.	Consultation to be undertaken by the Scottish Ministers
	The CMS must include, but not be limited to:  a) Details of the commencement dates, duration and phasing for the key elements of construction, the working areas, the construction procedures and good working practices for installing the Development.	Section 4.4 and Section 7
	b) Details of the roles and responsibilities, chain of command and contact details of company personnel, any contractors or sub-contractors involved during the construction of the Development.	Section 5  Note, contact details are not detailed within Section 5. NnGOWL will collate key personnel contact details into a Project Contact Register. This will be provided to MD-LOT separately once finalised and prior to Construction.



OFFSHORE CONSENTS REFERENCE	CONDITION	WHERE ADDRESSED
	c) Details of how the construction related mitigation steps proposed in the Application are to be delivered.	Section 8.4
	The CMS must adhere to the construction methods assessed in the Application.	Section 6 and 8
	The CMS also must, so far as is reasonably practicable, be consistent with a DS, the EMP, VMP, an NSP, the PS, the CaP and the LMP.	Section 1.3

### 1.3 Linkages with other Consent Plans

- This CoP and CMS document sets out the proposed offshore construction programme and installation methods for the Wind Farm and the OfTW infrastructure. However, ultimately it forms part of a suite of approved documents that provide the framework for environmental management of the Project – namely the other Consent Plans required under the consents.
- The other plans named in the relevant consents clearly have a link to the CoP and CMS document in so far as they either provide additional details on the construction methodology and / or provide details on the control of construction to mitigate potential environmental impacts and impacts on other marine users.
- The Consent Plans detailed in Table 1-2 will be submitted for approval by the Scottish Ministers and consistency between these will be achieved by ensuring that all relevant documents are consistent with the terms of any previously submitted or approved Consent Plans.

*Table 1-2: CoP and CMS linkages with other relevant Consent Plans (and consents conditions)*

OFFSHORE CONSENTS REFERENCE	CONSENT PLAN	LINKAGES WITH CMS COMPONENT OF THIS PLAN
<b>Section 36 Consent, Condition 13</b> <b>OfTW Marine Licence, Condition 3.2.2.18</b>	Design Statement (DS)	The DS includes representative Wind Farm visualisations from key viewpoints based upon the final Development Specification and Layout Plan and must be prepared and signed off by at least one qualified landscape architect; its purpose is to inform interested parties of the final Wind Farm scheme proposed to be built. The CoP and CMS presents the construction methods, good practice and mitigation measures for the Wind Farm and OfTW infrastructure as described in the DS (and the DSLP) produced for the Wind Farm. The overview of the Wind Farm and OfTW infrastructure as set out the CoP and CMS, is consistent with that detailed in the DS.
<b>Section 36 Consent, Condition 14</b> <b>Wind Farm Marine Licence, Condition 3.2.2.11</b>	Environmental Management Plan (EMP)	The EMP sets out the environmental management framework for the construction and operation of the Wind Farm and OfTW infrastructure. The installation and construction described in the CoP and CMS will be undertaken in line with the environmental management measures described in the EMP. In addition, specific good practice measures and mitigation measures are detailed within the CoP and CMS (these being consistent with the measures described in the EMP where relevant).

OFFSHORE CONSENTS REFERENCE	CONSENT PLAN	LINKAGES WITH CMS COMPONENT OF THIS PLAN
OfTW Marine Licence, Condition 3.2.2.10		
Section 36 Consent Condition 15 (VMP) and 17 (NSP) Wind Farm Marine Licence 3.2.2.12 (VMP) OfTW Marine Licence Condition 3.2.2.11 (VMP) and 3.2.2.12 (NSP)	Navigational Safety and Vessel Management Plan (NSVMP)	<p>The purpose of the NSVMP is to mitigate the impact of vessels throughout the construction period of the Project and will also consider operational management and coordination of vessels. The NSVMP details how vessel movements will be managed during construction and sets out the navigational safety measures to be applied for the Project including matters related to marine co-ordination, safety zones, routing, anchorages and notifications and communications for other sea users.</p> <p>This CoP and CMS refers to the same indicative construction vessels which are included in the NSVMP. The NSVMP will be implemented in parallel with this CoP and CMS and the measures described in the NSVMP will apply to the vessels undertaking the activities described in this CoP and CMS. This CoP and CMS will therefore be implemented in accordance with the approved NSVMP for the Project.</p>
Section 36 Consent, Condition 11 Wind Farm Marine Licence, Condition 3.2.2.10 OfTW Marine Licence, Condition 3.2.2.9	Piling Strategy (PS)	The PS contains further and greater detail on how the piling methods and programme have been developed to reduce effects on noise sensitive species. It provides the more detailed description of the piling procedures (and associated mitigation and monitoring) adding to the information contained in this CoP and CMS. The detailed information contained within the PS is not repeated within this CoP and CMS, but the piling operations described in this CoP and CMS will be undertaken in compliance with the more detailed procedures set out in the PS.
Section 36 Consent, Condition 19 Wind Farm Marine Licence, Condition 3.2.2.9 OfTW Marine Licence, Condition 3.2.2.8	Cable Plan (CaP)	Provides the more detailed specification of the cables, their installation, burial and/or protection, their interactions with the environment and safety considerations, adding to the information contained in this CoP and CMS. The detailed information contained within the CaP is not repeated within this CoP and CMS, but the summary of cable installation operations described in this CoP and CMS will be undertaken in compliance with the more detailed procedures set out in the CaP.
Section 36 Consent, Condition 20 OfTW Marine Licence, Condition 3.2.2.19	Lighting and Marking Plan (LMP)	The LMP provides details of lighting and marking of the Wind Farm structures during construction and operation is provided in the LMP. This detail is not repeated within this CoP and CMS; however, this CoP and CMS will be implemented in accordance with the approved LMP for the Wind Farm.

## 1.4 Structure of the Plan

- An overview of the structure of this CoP and CMS is provided below.

Table 1-3 :CoP and CMS document structure

SECTION	TITLE	SUMMARY OF CONTENT
1	Introduction	<p>Sets out consent requirements for a CoP and CMS and the document scope and structure; and</p> <p>Identifies those other Consent Plans with linkages to the CoP and CMS.</p>
2	NnGOWL Statements of Compliance	Sets out the NnGOWL statements of compliance in relation to the CoP and CMS.
3	Project Overview	Provides an overview of the Project.
4	Construction Programme	Provides an overview of key milestone dates during the construction of the Project.
5	Roles and Responsibilities	Provides a summary of the roles and responsibilities of key personnel and contactors during construction.
6	Construction Methods and Procedures	Provides further detail on each step of the installation process for the Project.
7	Good Working Practices	Sets out the good working practices that will be applied during the installation of the Project.
8	Compliance with the Application	<p>Sets out confirmation that the details set out in this CoP and CMS are in accordance with those assessed in the EIA Report and the Addendum; and</p> <p>Sets out how the mitigation measures related to construction identified in the EIA Report and the Addendum are to be delivered (by reference to this CMS or other relevant consent plans).</p>

## 2 NnGOWL Statements of Compliance

### 2.1 Introduction

9. The following section is intended to re-affirm the overarching NnGOWL commitments relating to the construction of the Project in such a manner as to meet the relevant requirements set out by the consents but also broader legislative requirements in respect of the guidance set out by the relevant bodies.

### 2.2 Overarching Statements of Compliance

10. NnGOWL, in undertaking the construction of the Project, will ensure compliance with this CoP and CMS as approved by the Scottish Ministers (and as updated or amended from time to time).
11. Where updates or amendments to this CoP and CMS are required, NnGOWL will ensure the Scottish Ministers are informed as soon as reasonably practicable and where necessary the CoP and CMS will be updated and amended.
12. NnGOWL, in undertaking the construction of the Project, will ensure compliance with the limits defined by the original Application, the project description defined in the Environmental Impact Assessment (EIA) Report and the Addendum of Additional Information (the Addendum) and referred to in Annex 1 of the S36 Consent in so far as they apply to this CoP and CMS (unless otherwise approved in advance by the Scottish Ministers / the Licensing Authority).
13. NnGOWL will, in undertaking the construction of the Project, ensure compliance with all other relevant legislation and require that all necessary licences and permissions are obtained by the Contractors and Subcontractors through condition of contract and by an appropriate auditing process.

### 2.3 Health and Safety, and Environmental Management

14. NnGOWL, in undertaking the construction of the Project, will comply with NnGOWL Health, Safety and Environment (HSE) systems and standards, the relevant HSE legislation and such other relevant legislation and guidance so as to protect the safety of construction personnel and other third parties.
15. Further detail on environmental management is set out, for approval, in the EMP; the installation of the Project described by this CoP and CMS will be undertaken in line with the procedures and practices set out in the EMP.
16. The Project is a notifiable project for the purposes of the Construction (Design and Management) Regulations 2015 (CDM Regulations). NnGOWL will ensure compliance with the CDM Regulations in the design of the Project and through the completion of the construction process. Although these are not environmental regulations, they have a profound influence on how construction is organised and therefore have an influence on environmental performance.

### 2.4 Equipment and Materials

17. All materials, plant or equipment will require to be audited, either during manufacture or prior to despatch from the suppliers' premises, by a suitably qualified discipline inspector or engineer. NnGOWL shall be satisfied that any vendor or contractor supplying goods which require traceability has an adequate system of unique identification to satisfy these requirements.
18. All goods and materials loaded on board construction vessels shall require to be checked against the relevant documentation such as services reports, repair orders, packing list, cargo manifests, purchase orders, material certificates, test reports or material specifications or such other documentation as may

be relevant. Inspections will include consideration of quality, quantity, identification numbering, damage in transit and general dimensions (and if such inspections are not or, due to circumstances, cannot be inspected in part or whole this will be noted).

19. If doubt arises as to the fitness for purpose of any supplied product it shall require to be clearly marked and quarantined until the suspected non-conformance can be resolved.
20. An appropriate system for the logging, storage, and marking of all equipment and materials will be required on each vessel. The supplier's special instructions and delivery notes will require to be complied with during handling, storage and installation with appropriate training or notification of personnel. The correct lifting procedures will require to be followed to ensure safe, efficient handling.

## 2.5 Construction Personnel – Training and Competence

21. NnGOWL will require that all personnel engaged in the construction process have adequate experience to perform the activities executed under their responsibility or in their scope.
22. NnGOWL will require that all Contractors and Subcontractors have sufficient manpower resources of the required competence to meet the contractual requirements and require that personnel performing specific assigned tasks on the Project will be qualified on the basis of appropriate education, training, competence and experience.
23. NnGOWL will require that all construction personnel attend inductions including, but not necessarily limited to, matters related to Site Rules, Health and Safety requirements, arrangements for First Aid and Emergency Response, and Environmental Management.

## 2.6 Construction Vessels

24. NnGOWL will require that all construction vessels meet the required, recognised standards and will comply with the international maritime rules (as adopted by the flag state) and regulations. Where necessary, NnGOWL will conduct appropriate independent vessel audits on all construction vessels to ensure they meet these standards and are fit for purpose for their prescribed roles.
25. All construction vessels will comply with the procedures and requirements set out in other relevant consent plans such as the NSVMP, the LMP and the EMP.

## 2.7 Good Working Practices

26. NnGOWL will require all possible good working practice is applied by the Contractors and Subcontractors throughout the construction process in seeking to minimise the risks to personnel, other sea users and the environment.

### 3 Project Overview

27. The Wind Farm Area is located to the northeast of the Firth of Forth, 15.5 km directly east of Fife Ness on the east coast of Scotland (See Figure 3-1). The Wind Farm Area covers approximately 105 km<sup>2</sup>. Offshore Export Cables are located within the 300 m wide Offshore Export Cable Corridor, running in an approximately southwest direction from the Wind Farm Area, making landfall at Thorntonloch beach to the south of Torness Power Station in East Lothian. Figure 3-1 shows the Wind Farm Area and Offshore Export Cable Corridor.
28. The Offshore Consents allow for the construction and operation of the following main components, which together comprise the Project:
  - 54 wind turbines with a maximum generating output of around 450 Megawatts (MW);
  - 54 jacket substructures installed on pre-piled foundations, to support the wind turbines;
  - Two alternating current (AC) substation platforms, referred to as Offshore Substation Platforms (OSPs), to collect the generated electricity and transform the electricity from 66 kV to 220 kV for transmission to shore;
  - Two jacket substructures installed on piled foundations, to support the OSPs;
  - A network of inter-array subsea cables, buried and/or mechanically protected, to connect strings of turbines together and to connect the turbines to the OSPs;
  - One interconnector cable connecting the OSPs to each other;
  - Two buried and/or mechanically protected subsea export cables to transmit the electricity from the OSPs to the landfall at Thorntonloch and connecting to the onshore buried export cables for transmission to the onshore substation and connection to the National Grid network; and
  - Minor ancillary works such as the deployment of metocean buoys and permanent navigational marks.
29. Offshore construction commenced in August 2020. Details of the construction programme are provided in Section 4 below.

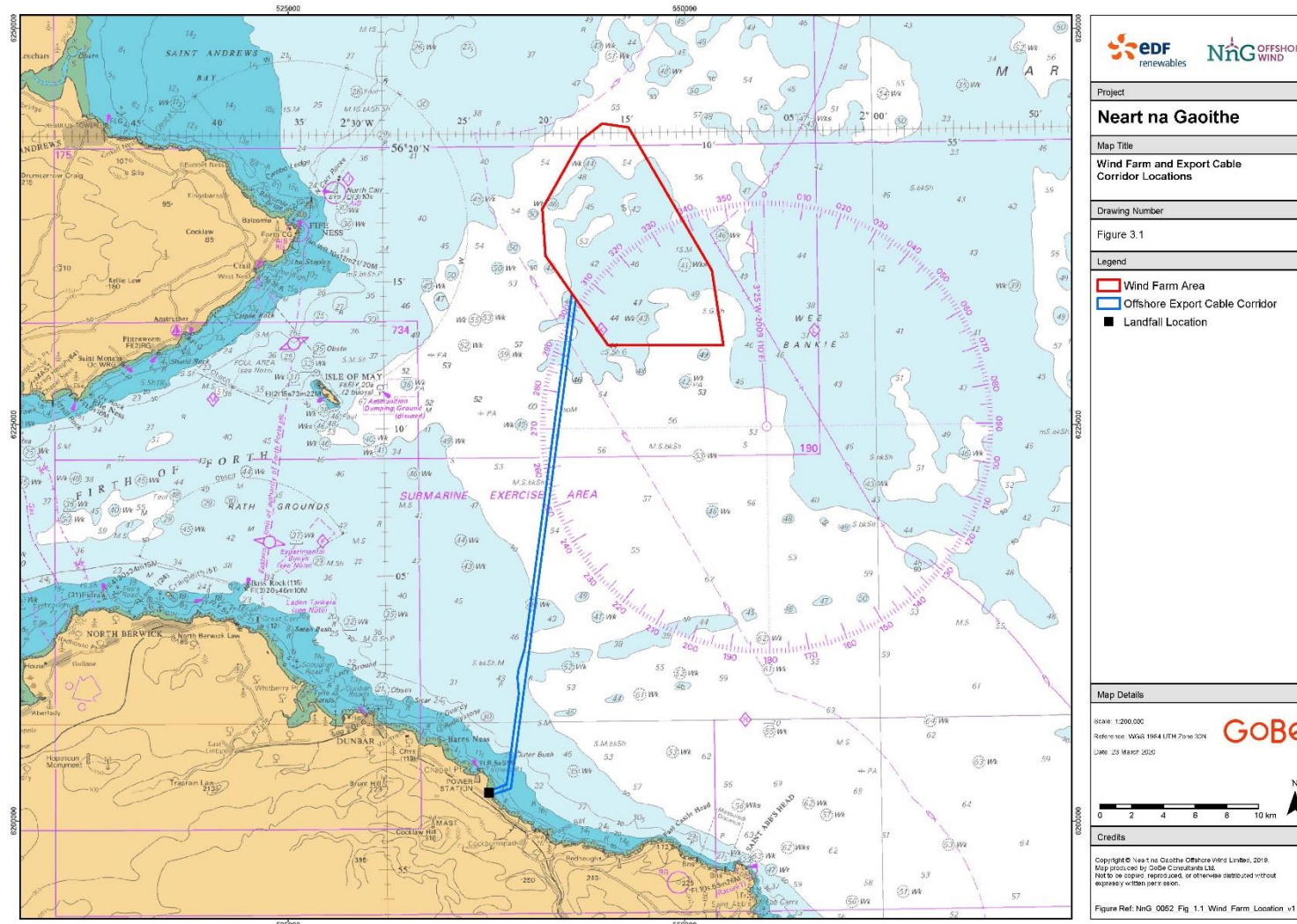

Figure 3-1: Wind Farm Area and Offshore Export Cable Corridor locations

## 4 Construction Programme

### 4.1 Introduction

30. This section sets out the programme for construction of the Wind Farm and OfTW infrastructure and presents the key milestone dates for the commencement of the works, the main construction activities and the commissioning of the Project.

### 4.2 Key Milestone Dates

31. The key milestone dates associated with the construction activities are presented in Table 4-1. The full CoP is presented in Figure 4-1. Dates presented in this section may be subject to further changes to take account of delivery of Project components, vessel availability, and minor operational refinements. Any variation to the dates presented will be notified to MD-LOT and incorporated into a future revision of this CoP and CMS as required.
32. The current revision of the programme, presented in Table 4-1 and Figure 4-1, has been updated following delays caused by the global COVID-19 pandemic.
33. Offshore construction works will be carried out year-round and on a 24-hour, 7-day per week basis unless otherwise noted.

Table 4-1: Summary of key milestone dates

MILESTONE	ANTICIPATED PROGRAMME
Final Commissioning	July 2025
<b>WIND FARM</b>	
Commencement of Wind Farm Construction	August 2020
Mobilisation of Plant, Delivery of Materials to Onshore Laydown Areas (where required)	To match installation timings as set out below. Onshore laydown of turbine components from March 2022 to December 2023.
Timing and Sequencing of Offshore Construction Work	<p>Casing and Pile Installation:</p> <ul style="list-style-type: none"> <li>Casing installation campaign 2020/21: August 2020 – June 2021</li> <li>Casing installation campaign: May 2022/23: June 2022 – September 2023</li> <li>Pile installation campaign: November 2021 – September 2023</li> </ul> <p>Wind turbine jacket installation:</p> <ul style="list-style-type: none"> <li>September 2022 – November 2023</li> </ul> <p>Installation of wind turbines:</p> <ul style="list-style-type: none"> <li>July 2023 – July 2025</li> </ul> <p>Inter-array Cable Installation:</p> <ul style="list-style-type: none"> <li>Pre-lay trenching: August – September 2021</li> </ul>



MILESTONE	ANTICIPATED PROGRAMME
	<ul style="list-style-type: none"> <li>Installation and burial campaign: April 2023 – July 2024</li> </ul>
<b>OFTW</b>	
Commencement of OFTW Works	August 2020
Mobilisation of Plant, Delivery of Materials to Onshore Laydown Areas (where required)	To match installation timings as set out below.
Timing and Sequencing of Offshore Construction Work	<p>Casing and Pile Installation:</p> <ul style="list-style-type: none"> <li>August 2020 – September 2023</li> </ul> <p>OSP Jacket Installation</p> <ul style="list-style-type: none"> <li>May 2022 – October 2023</li> </ul> <p>OSP topside installation:</p> <ul style="list-style-type: none"> <li>OSP South topside installation: June 2022</li> <li>OSP North topside installation: December 2022</li> </ul> <p>Export Cable Installation:</p> <ul style="list-style-type: none"> <li>May 2021 – August 2021</li> </ul> <p>Interconnector cable installation:</p> <ul style="list-style-type: none"> <li>April 2023</li> </ul> <p>Installation of ducts at landfall:</p> <ul style="list-style-type: none"> <li>September 2020 – May 2021</li> </ul>

### 4.3 Wind Farm Construction Programme

34. With reference to Figure 4-1 and in line with the requirements of the Section 36 Consents, the sections below detail the proposed:

- Date of commencement of construction of the wind farm;
- Timings for the mobilisation of plant and delivery of materials, including details of onshore laydown areas (where required);
- Timing and sequencing of construction work for all elements of the wind farm infrastructure;
- Contingency planning for poor weather or other unforeseen delays; and
- Scheduled date for final completion and commissioning of the wind farm

#### 4.3.1 Commencement of Wind Farm Construction

35. The S36 Consent defines the Commencement of the Wind Farm as:

*the date on which the first construction activity occurs in accordance with the EIA Report submitted by the Company on 16 March 2018.*

36. The first construction activity associated with the Project is pre-piling casing works, which commenced in August 2020.
37. The Commencement of the Wind Farm was therefore in August 2020.
38. Following Final Investment Decision (FID) on the Neart na Gaoithe Offshore Wind Farm in November 2020, orders were placed for components of the Project required early in the process, and those with long lead in times, including the wind turbines.
39. The delivery and stockpiling of materials and onshore fabrication activities to facilitate construction of the Wind Farm will commence prior to Commencement of the Wind Farm.



## 4.3.2 Mobilisation of Plant and Delivery of Materials

40. The key components of the Wind Farm are:

- Pile foundations and jacket substructures;
- Wind turbines; and
- Inter-array cabling.

41. The arrival of the plant required to install the Wind Farm components will be timed to coincide with the timing of the main installation activities, as set out in Section 4.3.3 below.

### 4.3.2.1 Pile Foundations and Jacket Substructures

42. The piled foundations will be delivered direct to the Wind Farm Area from the fabrication port or from a marshalling port. The jacket structures will be delivered direct from the port of fabrication.

### 4.3.2.2 Wind Turbines

43. The turbine components will be delivered to the construction port where they will be stored in an onshore laydown area for pre-assembly prior to loadout for installation.

44. Turbine deliveries from the manufacturing facility to the construction port are scheduled from March 2023.

45. It is envisaged that the turbine nacelles will arrive from the manufacturing facility almost complete and pretested, and that turbine pre-assembly will take place at onshore laydown areas at a construction port.

### 4.3.2.3 Inter-Array Cables

46. Deliveries of cables will be phased to match installation requirements. The cables are expected to be transported directly to site from the manufacturing facility.

47. Where required cable protection material will be transported directly to site from source.

## 4.3.3 Timing and Sequencing of Construction Work

48. The following sections detail the proposed timings and sequencing of construction work for all elements of the Wind Farm and relate to the construction programme provided in Figure 4-1. Pile Foundations and Jacket Substructures

49. Casing and pile installation is taking place across two campaigns, commencing in August 2020 and concluding in September 2023. Breaks between the two campaigns have been primarily driven installation vessel availability.

50. Jackets will be installed onto the pre-installed piles between the months of September 2022 and November 2023.

### 4.3.3.1 Turbine Installation

51. It is expected that there will be overlap in casing, pile, jacket and turbine installation campaigns. Turbine installation is scheduled to be completed over two campaigns taking place over a 24month period between July 2023 and July 2025. It is likely that turbine installation will proceed at a rate of approximately 2.5 turbines per week during installation campaigns and weather permitting.

52. Turbine commissioning timing varies, but is anticipated to be completed approximately 20 days after installation of each turbine.

#### 4.3.3.2 Inter-Array Cable Installation

53. A pre-lay trenching campaign took place between August and September 2021, within which trenching or jetting took place in areas of harder sediment (stiff clay and/or bedrock). A pre-, interim and post-survey was undertaken during the works to monitor progress. In addition, a trial burial of cable took place, with approximately 300m of cable to be installed and subsequently removed.
54. Inter-array cable installation took place between April 2023 and March 2024. During this time cables were be laid. Termination and testing of the cables will continue until all turbines are commissioned.

#### 4.3.4 Contingency Planning

55. Given the nature and scale of the construction project the potential exists for unforeseen delays, including from periods of unsuitable weather and equipment failure which are out of NnGOWL's control.
56. NnGOWL has undertaken weather analysis and assessed programme risks based on offshore construction experience; the construction programme set out in Figure 4-1 has been designed with reasonable contingencies included.

#### 4.3.5 Final Commissioning of Development

57. Annex 3 of the S36 Consent defines Final Commissioning of the Wind Farm as:

*'the date on which the last wind turbine generator constructed forming the Development [Project] has supplied electricity on a commercial basis to the National Grid, or such earlier date as the Scottish Ministers deem the Development to be complete.'*

58. As each turbine is commissioned it will commence operating and will supply electricity to the National Grid. Commissioning of the first turbine is scheduled for May 2024. The anticipated date of Final Commissioning of the Wind Farm is scheduled to be July 2025.

### 4.4 Offshore Transmission Works Construction Programme

#### 4.4.1 Introduction

59. The Project construction programme is presented in Figure 4-1. With reference to Figure 4-1 and in line with the requirements of the Marine Licence condition, detailed information in relation to the OfTW is set out below in the following sections:
  - Date of commencement of the OfTW;
  - Timings for the mobilisation of plant and delivery of materials, including details of onshore laydown areas (where required);
  - Timing and sequencing of construction work for all elements of the OfTW infrastructure;
  - Contingency planning for poor weather or other unforeseen delays; and
  - Scheduled date for final commissioning of the OfTW.

#### 4.4.2 Commencement of Works

60. The OfTW Marine Licence defines the Commencement of the OfTW as:

*'the date on which the first vessel arrives on the Site) to begin carrying on any Licensed Activities in connection with the construction of the Works.'*

61. The first elements of the OfTW to be installed are the OSP piles, which were installed between August 2020 and November 2021, respectively. This is when the first vessel arrived on site to begin carrying out OfTW licensable marine activity.
62. The Commencement of the OfTW was therefore August 2020.
63. Following FID on the Project, orders have been placed for components of the Project required early in the process, and those with long lead in times, including, for example, the export cables and OSPs.

#### 4.4.3 Mobilisation of Plant and Delivery of Materials

64. The key components of the OfTW are:
  - Two OSPs;
  - One OSP interconnector cable;
  - Two offshore export cables (and cable protection material (as required)); and
  - Horizontal cable ducts at the landfall.
65. The OSP topsides will be installed upon similar specification jackets on pile foundations as the turbines; the installation of the piled foundations and jackets to support the OSPs will fall within the periods of pile and jacket installation described in Section 4.3 above.
66. All main elements of the OfTW will be delivered directly to the Wind Farm Area and Offshore Export Cable Corridor from the location of fabrication as required; no onshore laydown areas will be required for the completion of the OfTW installation process.

##### 4.4.3.1 OSPs

67. The piles and jackets fabrication and supply for the OSPs will be undertaken at the same time as the turbines (please see Section 48 above).

##### 4.4.3.2 OSP Interconnector Cable

68. The OSP interconnector cable will be fabricated, transported and installed as part of the inter-array cables campaign as detailed under Section 4.3.2.3.

##### 4.4.3.3 Export Cables

69. Deliveries of cables will be phased to match installation requirements. The cables will be transported to the Offshore Export Cable Corridor directly from the manufacturing facility.
70. Where required cable protection material will be transported directly to site from source.

#### 4.4.4 Timing and Sequencing of Construction Work

71. The following sections detail the proposed timings and sequencing of construction for all elements of the OfTW and relate to the construction programme provided in Figure 4-1.

##### 4.4.4.1 OSP Installation

72. OSP topsides were installed between June 2022 and December 2022.

##### 4.4.4.2 OSP Interconnector Cable

73. The OSP interconnector cable will be installed during the inter-array cable installation campaign as detailed under Section 4.3.3.2.

#### 4.4.4.3 Export Cable Installation

74. Each of the export cables (and any required cable protection material) was installed in a single length from the landfall site to the OSP locations. The installation of the two export cables was completed between May 2021 and August 2021.

#### 4.4.4.4 Installation of Horizontal Ducts at Landfall

75. The export cables make landfall at Thorntonloch beach on the East Lothian coast. Horizontal directional drilling (HDD) / open cut trenching and duct installation is required to allow burial of the cables. Offshore installation of horizontal ducts was completed between September 2020 and May 2021.

#### 4.4.5 Contingency Planning

76. Given the nature and scale of the construction project the potential exists for unforeseen delays, including from periods of unsuitable weather and equipment failure which are out of NnGOWL's control.
77. NnGOWL has undertaken weather analysis and assessed programme risks based on offshore construction experience; the construction programme set out in Figure 4-1 has been designed with reasonable contingencies included.

#### 4.4.6 Completion of the Works

78. The OfTW Licences defines the completion of the Works associated with the OfTW licence as:

*'the date on which the Works have been installed in full, or the Works have been deemed complete by the Licensing Authority, whichever occurs first.'*

79. All export cables were installed by August 2021. Due to delays attributed to the global COVID-19 pandemic, the offshore export cables and OSP-South are still currently being commissioned while OSP-North is scheduled to be commissioned in 2023.
80. The proposed date for the Final Commissioning of the OfTW is July 2025, which coincides with that for the Wind Farm, as this is the date that electricity will be exported from all wind turbines forming the Wind Farm.

## 5 Construction Roles and Responsibilities

### 5.1 Introduction

82. The following sections set out the key roles and responsibilities for each of the main parties involved in the construction and installation process. The organisational arrangements and interfaces for the NnGOWL construction team are set out in organograms and the main roles and responsibilities in relation to the main, overarching construction process are described.

### 5.2 NnGOWL Roles and Responsibilities

83. The Project is a notifiable project for the purposes of the Construction (Design and Management) Regulations 2015 (CDM Regulations). NnGOWL will assume the role of Principal Contractor on the project and will be responsible for ensuring compliance with the CDM Regulations in the design of the project and through the completion of the construction process.
84. A summary of the NnGOWL organisational structure and the key roles during the construction of the Project is set out in Figure 5-1. The main responsibilities associated with each role are described in Table 1-1.

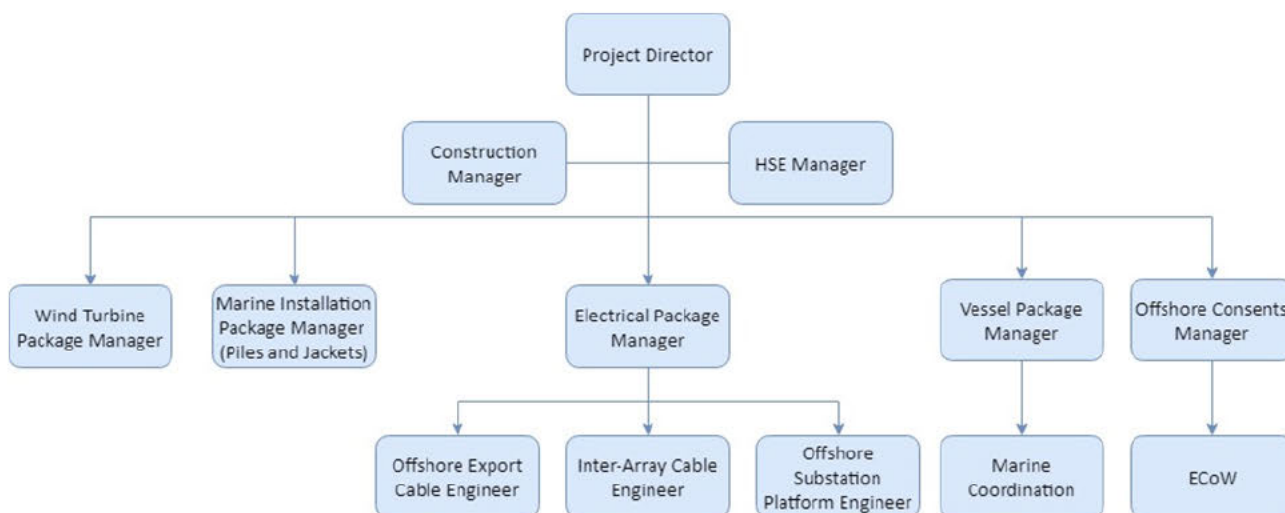

Figure 5-1: NnGOWL organisational structure

Table 5-1: NnGOWL roles and responsibilities

ROLE	RESPONSIBILITIES
<b>Project Director</b>	Overall responsibility for the Project delivery. The Project Director is accountable to the NnGOWL board for the project delivery strategy and the effective governance of the Project.
<b>Construction Manager</b>	Overall responsibility for construction and commissioning of the Project up to the handover to the operations and maintenance function.
<b>HSE Manager</b>	The HSE Manager is a member of the project management team responsible for providing support, advice and guidance on all aspects of Health, Safety & Environmental management on the Project.



ROLE	RESPONSIBILITIES
<b>Package Managers</b>	<p>Responsible for ensuring sufficient resources and processes are in place across their work packages to deliver the construction phase of the Project in accordance with the overarching construction processes detailed within this CoP and CMS.</p> <p>The Package Managers will be the key interface point with the respective contractors engaged on the Project.</p>
<b>Electrical Package Engineers</b>	<p>The Electrical Package Engineers are responsible for the successful delivery of their sub-packages ensuring design, delivery, commissioning and reporting meets the contractual requirements and programme.</p> <p>The Electrical Package Engineers may be the key interface for contractors delivering scope of works associated with the sub-package.</p>
<b>Offshore Consents Manager</b>	<p>The Consents Manager is responsible for the effective management of all consent, planning permission and land related activities through the pre-construction refinement and construction phases of the project. The Consents Manager will manage the Environmental Clerk of Works (ECoW).</p>
<b>Marine Coordinator</b>	<p>The Marine Coordinator will coordinate all activities on site including all vessel and personnel movements and site surveillance.</p>
<b>Environmental Clerk of Works</b>	<p>The ECoW will ensure the Project is constructed in compliance with this CoP and CMS, the wider suite of consent plans and the Application. The ECoW will interface with the Package Managers and report to the Offshore Consents Manager. In addition, the ECoW will also report directly to MD-LOT as detailed in the NnGOWL EMP.</p>

### 5.3 Contractors

85. NnGOWL have appointed six main Contractors to install the main components of the works described in this CoP and CMS. The key responsibilities of the main Contractors are set out below and the interface with the NnGOWL project team are set out under Section 5.2.
86. The relevant Scope of Works in relation to each package is detailed in Table 5-2.

Table 5-2: Key contractor roles and responsibilities

SCOPE OF WORKS	CDM DUTY	CONTRACTOR(S)
Supply and commissioning of turbines	Contractor	Siemens Gamesa Renewable Energy
Transport and installation of turbines	Contractor	Fred Olsen Windcarrier
Supply and installation of piles and jackets for turbines and OSPs	Contractor	Saipem Burntisland Fabrication
Supply and commissioning of OSP topsides	Contractor	GE Renewable Energy and consortium partner HSM Offshore BV

SCOPE OF WORKS	CDM DUTY	CONTRACTOR(S)
Transport and installation of OSP topsides	Contractor	Saipem
Supply and installation of inter-array and interconnector cables	Contractor	DEME Offshore
Supply and installation of export cables	Contractor	Prysmian Group
Definition of management procedures for offshore works Definition of construction site rules Marking of the construction site Provision of weather forecasts and site data to ensure works can be done safely Coordination of all contractors getting access to works areas via a Marine Coordinator and Permit to Work system	Principal Contractor	NnGOWL

5.4 Subcontractors

- 87. The main Contractors will be responsible for identifying and contracting subcontractors such as may be required to provide services for the completion of the construction works.

## 6 Construction Methods and Procedures

### 6.1 Introduction

88. The following sections set out the installation process for the main construction components covered by this CoP and CMS, namely:
- Seabed preparation;
  - Pile foundations and jacket substructures;
  - Wind turbine generators (including tower sections);
  - Inter-array cabling;
  - Offshore substation platform topsides;
  - Offshore export cabling;
  - Interconnector cabling; and
  - Electrical connection and commissioning.
89. A simple overview of the construction sequence is provided in Section 6.2 below, followed by more detailed information for each of the main elements of the sequence.
90. Good working practices to be applied during construction are described separately under Section 7.

### 6.2 Overview of the Project Construction Process

91. Figure 6-1 shows a simple flow diagram for the main stages in the installation of the wind turbine and OSP structures respectively. Cross references to the detailed sections that follow are provided.

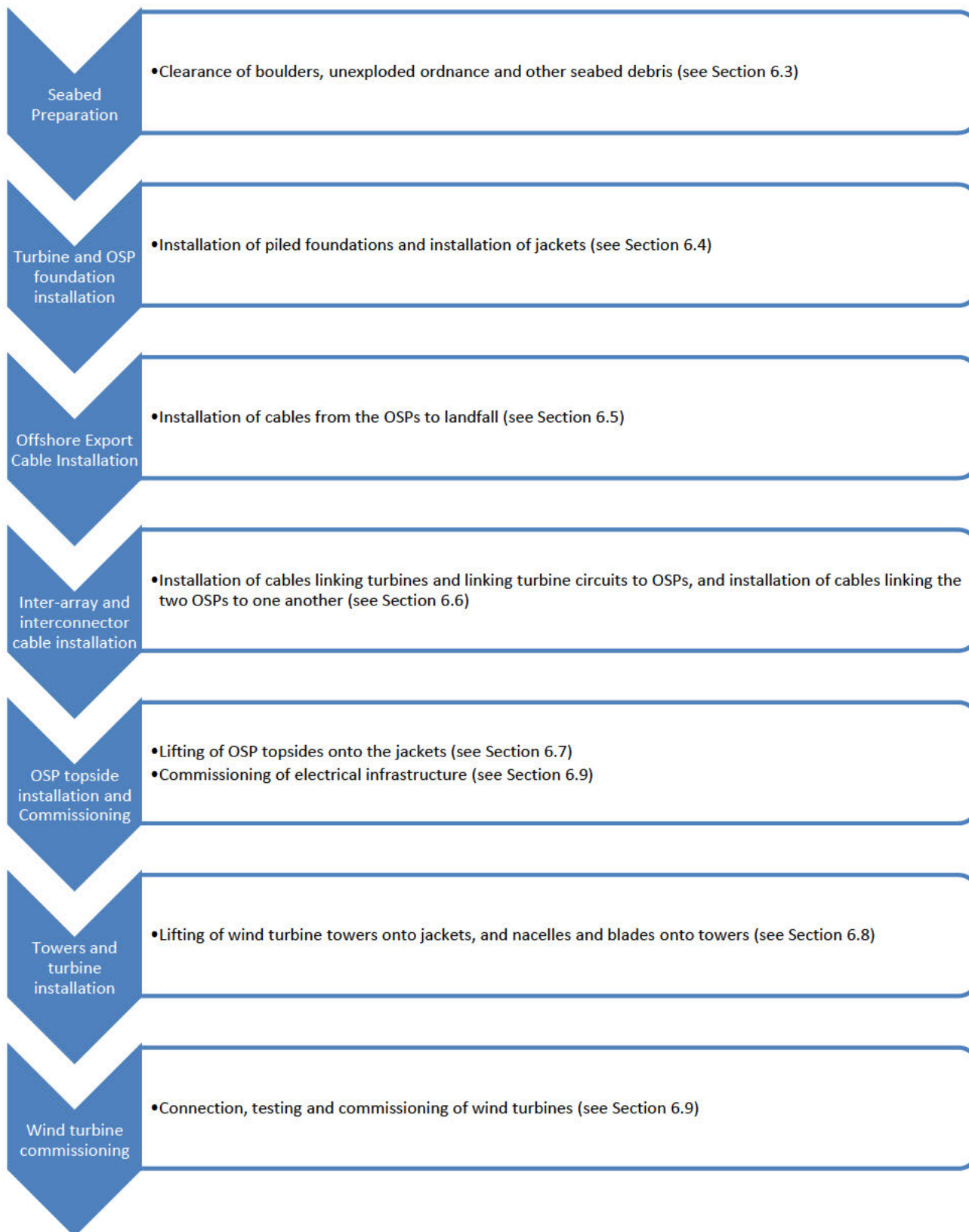

Figure 6-1: Overview of the Wind Farm and OfTW installation process

### 6.3 Seabed Preparation

- 92. Analysis of ground conditions in the Wind Farm Area and Export Cable Corridor has identified the potential for boulders, unexploded ordnance (UXO) and other debris to be present on and in the seabed, which may affect construction activities.
- 93. The strategy for dealing with boulders, other debris and UXO is summarised below. Further pre-construction surveys were undertaken to accurately confirm the presence and location of these features on the seabed. Boulder clearance and UXO clearance is subject to separate Marine Licences, granted in December 2019 (varied in June 2020 and May 2021) and NnGOWL submitted an application to vary in November 2023.

#### 6.3.1 Boulder Clearance

- 94. In areas where boulder presence may inhibit cable or foundation installation, a boulder clearance campaign has been undertaken. Further minor boulder clearance campaigns may take place should micro-siting of turbine locations be required. Two methods have been employed to date, depending on the number of boulders present.
- 95. At the majority of locations, a grab was used to remove individual boulders. A boulder grab was positioned over the approximate object location using the vessel dynamic positioning (DP) system. Using a combination of the GPS position and cameras (or acoustic devices depending on the visibility) the operator located the target and moved the boulder grab into position above it. The grab was then lowered over the boulder and the boulder was lifted off the seabed and deposited in close proximity to the boulder location.
- 96. If required in future campaigns, for areas with a large number of boulders present, a towed plough unit may be used to clear the route. The plough is towed over the seabed and pushes boulder or debris to either side of the cable route.

#### 6.3.2 Unexploded Ordnance

- 97. A detailed geophysical survey identified potential UXO targets on/in the seabed. All target data was reviewed by specialist UXO consultants who identified potential UXO that may cause a threat to the installation of cables and foundations.
- 98. Avoidance of UXO is the primary method of risk mitigation. Where some UXO cannot be avoided, they were individually inspected by a ROV to confirm the item to be a UXO. Where appropriate and safe to do so the UXO a charge was placed on the UXO target and detonated. A further visual inspection was undertaken to confirm that the item has been destroyed. Where UXOs did not detonate, or if it was confirmed that the UXO target was safe these were relocated within the UXO clearance area to ensure there is no further risk to installation activities.

### 6.4 Pile Foundations and Jacket Installation

#### 6.4.1 Components to be Installed

- 99. The main components that will be deposited or installed are summarised in Table 6-1.

Table 6-1: Summary of foundation components to be deposited or installed

COMPONENT	NUMBER	KEY DIMENSIONS
Turbine foundation casings	54 x 3	Outer diameter: up to 3.5 m Average Length: 11.5 m
Turbine foundation piles	54 x 3	Pile Diameter: up to 3.2m Pile Length: up to 60 m
Turbine jacket substructures (including transition piece, which connects the jacket with the turbine tower)	3-legged jacket substructures	Height 83 to 88 m Size at seabed (pile centre to pile centre): 30 m
OSP foundation casings	2 x 3	Outer diameter: up to 3.5 m Average Length: 11.5m
OSP foundation piles	2 x 3	Pile Diameter: 2.7 m Pile Length: up to 60 m
OSP jacket substructures	3-legged jacket substructures	Height 83 to 88 m Size at seabed (pile centre to pile centre): 30 m
Grouted pile connection	168 piles	

### 6.4.2 Delivery to the Construction Site

100. The piles, jackets and grout will be delivered directly to the Wind Farm Area by sea from the site of fabrication or a marshalling port.

### 6.4.3 Method and Process of Installation

101. An indicative pile and jacket substructure installation sequence is presented in Figure 6-2 below. Greater detail on each of the stages in the installation process (F1 – F7) is then provided in the subsequent sections.
102. Throughout the campaigns, pile and jacket installation will be variously undertaken from a Semi-Submersible Crane Vessel (SSCV), Monohull heavy lift vessel (HLV) and Jack Up Vessel (JUV) dependent upon vessel availability. Installation methods will be similar whether undertaken from the SSCV, HLV or JUV. The SSCV/ JUV/ HLV will be assisted by a Platform Support Vessel (PSV) that will deliver casings and piles to the Wind Farm Area, and an Offshore Support Vessel (OSV) to assist with various pre-installation activities and grouting. Alternatively, the JUV may return to port to collect casings and piles and transport to the Wind Farm Area. Total drilling duration for each foundation installation is estimated to be between 140 and 220 hours excluding any weather delays. The pile preparation (including survey, cleaning (where applicable), shroud installation), pile installation and pile grouting requires between a further 350 and 450 hours, although some of these activities are concurrent.

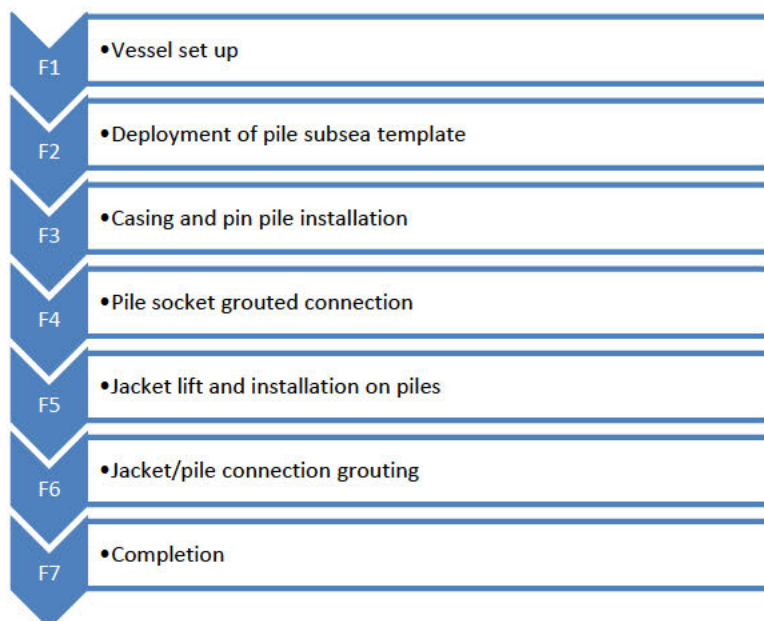

Figure 6-2: Foundation and jacket substructure installation sequence.

6.4.3.1 Foundation Installation Stage F1 – Vessel Set Up

- 103. The installation vessel, either SSCV / JUV / HLV, arrives at the proposed pile installation location and is positioned in readiness for the foundation installation works. The JUV legs are jacked down onto the seabed to ensure the vessel remains in position during installation. The SSCV / HLV activates its dynamic positioning (DP) system which will be used during installation.
- 104. Note that visual seabed surveys may be performed to confirm seabed conditions prior to pile installation. This may be undertaken from the SSCV/ JUV / HLV or from a separate OSV.

6.4.3.2 Foundation Installation Stage F2 – Subsea Template (SST) Set Up

- 105. Pile installation will be aided by use of casings and a Subsea Template (SST), which will allow accurate placement of piles and provide stability during installation. The SST will be deployed onto the seabed either using the SSCV crane, or in the case of the JUV, an HLV will be used to deploy the SST prior to the JUV arriving at the location. Once drilling commences the casings will be inserted in parallel with drilling operations.
- 106. The SST will be capable of levelling itself to accommodate slopes up to 5° on the seabed and will be equipped with survey equipment to allow constant monitoring of its position.
- 107. After all piles have been installed at a location, the SST is recovered for re-use at the next location. Alternatively, the SST may be recovered once the sockets have been drilled and prior to pile installation and separate equipment deployed to aid the pile installation.

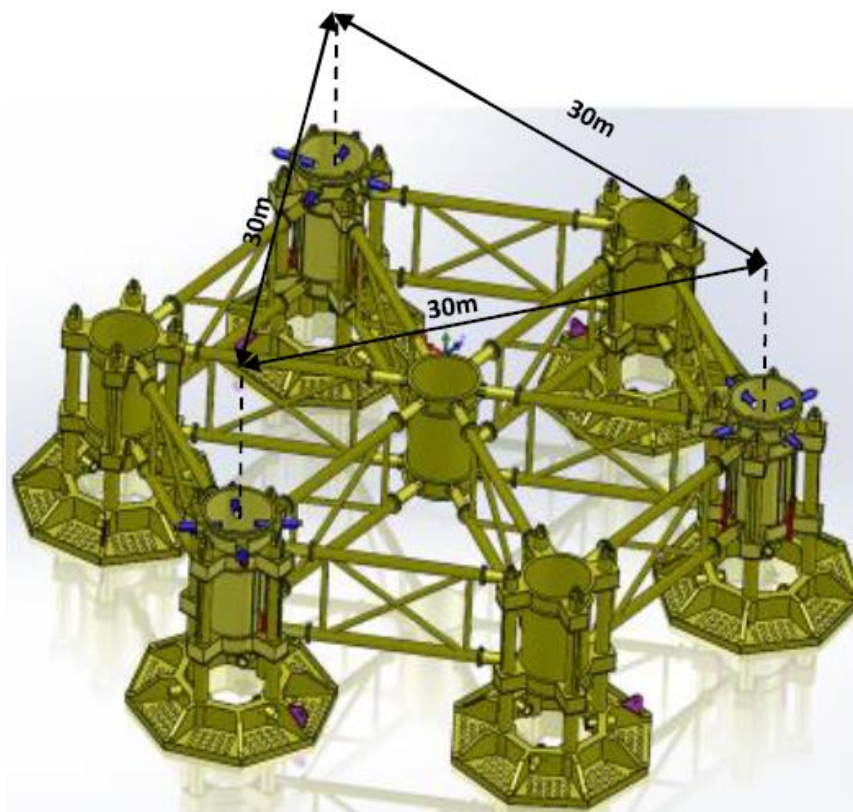

Figure 6-3: Illustration of the SST

#### 6.4.3.3 Foundation Installation Stage F3 – Pile Installation

108. Steel duct casings will be installed into the seabed to guide drilling of the pile socket, within which the pile will sit when installed. The casings not only guide drilling but support the drilled hole and prevent its infilling with seabed material. The casing will be installed under its own weight and using a drill-only method at the majority of locations. At some locations, due to ground conditions, it may be required to partially hammer the casings into the seabed, as part of a drive-drill-drive solution.
109. Once the SST is in position, the SSCV/ JUV crane will lift a casing and place ('piggy-back') this onto the drill string that will be used to drill the pile socket. The SST will be fitted with hydraulically operated guides that will control the verticality of the casing. The casing and drill string will then be lowered through a sleeve of the SST and into the seabed sediment. The casing will penetrate the seabed sediment under its own weight and be further installed into the seabed using a jacking system integrated with the drill and SST. The drill has an under-reaming capability and is used to enlarge the socket below the casing and in harder ground conditions, enabling further penetration of the casing into the seabed to the desired depth.
110. Where the casing is installed by drive-drill-drive, the casing will be placed into the SST using a lifting tool and will penetrate the seabed under its own weight. A follower (a member between the hammer and the casing to transmit blows to the casing when the top of it is below the reach of the hammer) and hydraulic hammer will then be lifted onto the casing and will drive the casing to a pre-defined depth within the overburden layer. The follower and hammer will then be recovered, and the drill will be deployed to remove the soil heave by drilling out the inside of the casing and, if required, perform under-reaming ahead of the casing. The drill is then recovered, and the follower and hammer are deployed again to drive the casing further into the ground. This cycle may be repeated until the casing reaches the



target penetration depth. The number of cycles are case specific but it is anticipated that most locations will require one cycle.

111. Once the casing is at target depth and stable, the drill tool is engaged and used to drill the pile socket to the target depth (Figure 6-4). Drill spoil will be released into the water column at the top of the drill tool. Once the target socket depth is achieved the drill is recovered and this process is then repeated for the remaining piles at that location.
112. The SSCV/ JUV / HLV crane will then upend the first pile and lower it through the casing into the drilled socket using an Internal Lifting Tool (ILT) which grips the inside of the pile for lifting. The pile will be centralised within the sacrificial casing using the lower SST grippers, or by Pile Stabilization Tools (PSTs) if the piles are to be installed after the SST is lifted. PSTs are steel bags or mechanical screw jackets that are fixed to the pile at numerous headings. They are inflated with seawater to fix the piles in place or screwed into the correct position, relative to the casings. The PSTs will remain in place when grouted and then recovered once the grout has cured.
113. Once the piles are in position within the rock sockets grouting operations commence. The grouting may be performed by the OSV. Once grouting of the socket is completed the SST is then raised above the pile stick up and retrieved to the vessel using the SSCV/HLV crane. The SSCV/ HLV / JUV relocates to the next foundation location.
114. When the SSCV/JUV / HLV has installed all piles loaded out at first mobilisation, a PSV or Coaster will deliver additional piles to the Wind Farm Area. Both vessels will maintain positioning using DP and the piles and grout will be loaded onto the SSCV/ HLV by crane. Alternatively, the Coaster may be moored to the HLV using a procedure agreed by the vessel masters.
115. It may also be the case that the JUV will return to a marshalling port and collect casings / piles for the next locations.

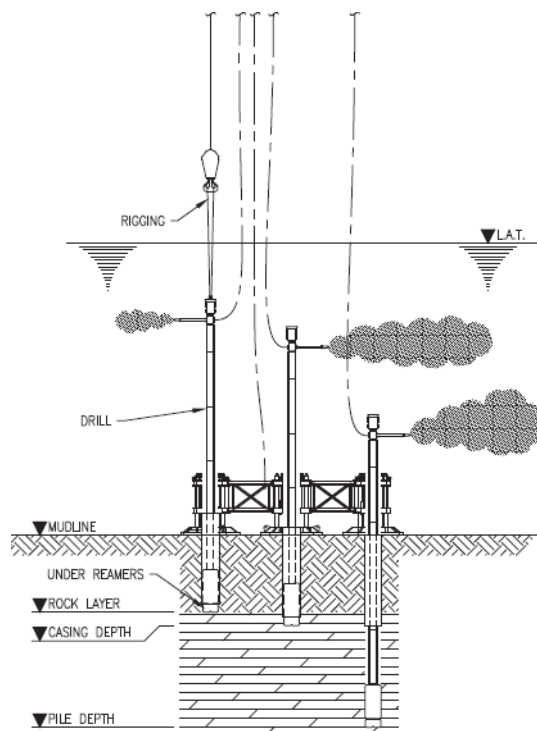

Figure 6-4: Illustration of drilling operations

6.4.3.4 Foundation Installation Stage F4 – Pile socket grouted connection

- 116. Once the piles are in position within the rock sockets grouting operations commence, with a grout such as Ordinary Portland cement or Masterflow inserted into the pile annulus to fix the pile within the rock socket. This is then repeated at the remaining locations and the installed piles remain sticking up above the seabed.
- 117. The grout shall be continually pumped into the relevant locations and grout specific gravity measurements will be taken to determine density at the seabed by means of an ROV-held nuclear densitometer or alternative. The grout pumping will stop once the required density has been obtained.
- 118. Grouting will take place from either the SSCV/JUV/HLV or OSV.

6.4.3.5 Foundation Installation Stage F5 – Jacket Lift and Installation

- 119. Once piling is complete at all locations, the SSCV will prepare for the installation of the jacket substructures onto the pre-installed piles. For jacket installation the SSCV may be supported by one or two Offshore Construction vessels (OCVs).
- 120. Prior to installation of the jacket the pile stick ups will be cleaned of marine growth. The pile cleaning tool will be deployed from the SSCV or an OCV and will use water jets to clean the inside of the pile (Figure 6-5). Once cleaned it is required that the jacket is installed within 7 days to ensure a clean surface to facilitate grout bonding.



Figure 6-5: Pile cleaning tool

- 121. The SSCV / OCV will also deploy a ROV to undertake a seabed survey to confirm there are no obstructions on the seabed.
- 122. Jackets will either be delivered to the Wind Farm Area by an HTV / Barge or arrive in the Wind Farm Area on the SSCV deck. The HTV/ Barge will be held in position by two assist tugs within the Wind Farm Area away from any installed structures. The HTV / Barge will then relocate to the turbine location and the assist tugs will help maintain the HTV / Barge at an optimum orientation while the SSCV approaches. The SSCV will then moor alongside the HTV / Barge and lift the jacket from the HTV.
- 123. The SSCV will then relocate to the turbine location and the HTV / Barge will move off. The SSCV will continue to maintain its position by DP. The SSCV will lift and lower the jacket onto the pre-installed piles assisted by controlled tugger lines and observed by an ROV (Figure 6-6).
- 124. One of the jacket pile tops will stick-up approximately 1 m higher above mudline than the remaining two piles. This approach is adopted with the intention to assist the jacket setdown operations. The primary

jacket leg will be located into the corresponding (high) pile first, while the remaining two legs are installed into their socket piles simultaneously.

125. The jacket and piles are designed to allow the jacket to be left temporarily ungripped on the seabed subject to a suitable weather window. The SSCV will derig the jacket and leave the jacket in place. To optimise vessel operation an OCV may be used to finish jacket installation. If a weather window is not available to complete operations pile grippers will be actuated by the SSCV to ensure stability until a grouted connection can be achieved.



Figure 6-6: Deployment of the jacket from the SSCV

#### 6.4.3.6 Foundation Installation Stage F6 – Jacket Grouting

126. Once the jacket is installed, grouting at the piles can commence. The purpose of grouting is to establish a sound and reliable connection between the piles drilled into the seabed and the jacket mounted on top of the piles.
127. To level the jacket the SSCV / OCV crew will access the top of the jackets via a basket transfer, walk to work gangway or a crew transfer boat. The SSCV / OCV survey team will check the level of the jacket to determine the magnitude of levelling required. The jackets legs will be installed with pile grippers that will be hydraulically operated and will be capable of levelling the jacket on the pre-installed piles. If levelling is required hydraulic lines will be transferred to the top of the jacket where it will be possible to connect to the levelling system. The grippers on the jacket legs will then level the jacket and hold the jacket in place while grouting is completed.
128. The annulus between the jacket leg and the pile shall be grouted with a grout such as Masterflow 9800 as soon as a suitable weather window exists after the jacket is level and securely gripped.

129. Grouting will be conducted from the SSCV or an OCV. Grout lines will be connected at the top of the jackets and pumped through the jacket legs into the annulus. As detailed above in relation to the socket connection a ROV-held nuclear densitometer will take measurements of specific gravity to determine the density of the grout. The initial curing time of the grout will be a minimum of 24 hours. As a back up to grouting from the surface, grouting can also be completed using ROV to connect grout stingers through holes in the gripper system to insert grout at the seabed.

#### 6.4.3.7 Foundation Installation Stage F7 – Completion and Move Out

130. Personnel on the jacket will install aids to navigation in accordance with the LMP and ensure the jacket is ready to receive the turbine tower. A post installation ROV survey will also be conducted from the SSCV / OCV to confirm that the pile connections are all intact.

131. Based on the sequence of installation of inter-array cables and WTGs, some WTGs are expected to experience a period of standstill. Where a WTG is not energised, the environmental controls (e.g. heating and dehumidification) within it will not be operational, which may result in condensation and corrosion of internal WTG components. WTG standstill and an absence of moving parts can also impact on WTG components such as blade bearings, which require regular lubrication. Should a prolonged standstill period be encountered, precautionary measures will be taken to ensure preservation of the WTGs; this will involve installation of an external temporary diesel generator with a capacity of minimum 120 kVA to ensure the WTG can pitch and yaw upwind automatically during the entire standstill period. The temporary generator is mounted on the Transition Piece external platform in accordance with manufacturer’s instructions; and is sufficiently fuelled for the duration of the standstill period.

### 6.5 Offshore Inter Array and Interconnector Cable Installation

#### 6.5.1 Components to be Installed

132. The inter-array and interconnector, collectively referred to as the offshore electrical infrastructure, connect the turbines to one another and to the OSPs. The full cable arrangement is provided in the DSLP.

133. The main components to be deposited or installed are summarised in Table 6-2.

*Table 6-2: Offshore Inter Array and Interconnector Cable specifications*

COMPONENT	DESCRIPTION	KEY DIMENSIONS
<b>Inter-array cabling</b>	3 core 66 kV armoured XLPE AC cable	Approximately 94 km in total length (subject to micro-siting)
<b>Interconnector cable</b>	3 core 66 kV armoured XLPE AC cable	Approximately 4 km in total length (subject to micro-siting)

#### 6.5.2 Delivery to the Construction Site

134. The inter-array cables and interconnector cable will be collected at the port of manufacture by the CLV and will be transported to the Wind Farm Area.

#### 6.5.3 Pre-lay trenching Campaign

135. The majority of the inter-array cables are located in soft clay or sand substrates and are anticipated to be installed by a jetting method. The remaining areas (approximately 31km) are of harder sediment (stiff clay and/or bedrock) where either jetting or mechanical cutting is required to reach the target depth of lowering (DoL).

- 136. In order to mitigate the risks correlated with hard cohesive soil and bedrock, and gain more knowledge of the soil profiles, mechanical cutting and jetting trials will take place ahead of the IAC cable installation campaign in 2023, in those areas of harder sediment only. The pre-lay trenching campaign will take place between August and September 2021.
- 137. The work will not include laying of cabling, only the deployment of the burial tool. The same mechanical cutting method and hybrid cable trenching tool described in Section 6.5.4.4 will be used. In addition, a trial burial of cable will take place, with approximately 300m of cable to be installed and subsequently removed. Pre-, interim, and post- surveys will be undertaken to monitor progress ahead of the full cable lay and burial campaign.

**6.5.4 Method and Process of Installation**

- 138. An indicative inter-array and interconnector cable installation sequence is presented in Figure 6-7 below. Greater detail on each of the stages in the installation process (IAC-1 – IAC4) is then provided in the subsequent sections.
- 139. Cable installation will be completed by a single CLV.

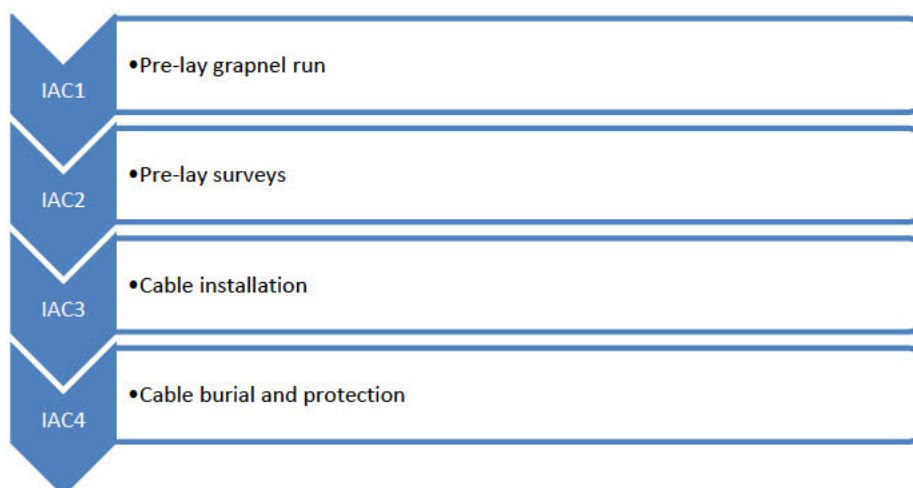

*Figure 6-7: Offshore inter-array and interconnector cable installation sequence*

**6.5.4.1 Offshore Inter-Array and Interconnector Cable Installation Stage IAC1 – Pre-lay grapnel run**

- 140. Seabed debris or features (for example scrap trawler warps or ships’ crane wires that may have been jettisoned by vessels onto the seabed) can be detrimental to the trenching or burial tool. Therefore, after boulder clearance and before the start of cable laying operations the cable route will be cleared of any remaining obstructions by undertaking a pre-lay grapnel run (PLGR).
- 141. An anchor handling tug will be mobilised with a towed grapnel rig. All intended cable routes will be subject to PLGR.

**6.5.4.2 Offshore Inter-Array and Interconnector Cable Installation Stage IAC2 – Pre-lay Surveys**

- 142. The CLV or a dedicated survey vessel will perform a pre-lay survey as part of the cable installations. Surveys will be completed after the CLV is loaded and has arrived at site to ensure no changes that will affect the cable installation has occurred since the previous surveys. A ROV will be used to carry out the pre-lay survey.

### 6.5.4.3 Offshore Inter-Array and Interconnector Cable Installation Stage IAC3 – Cable Installation

143. Cable installation is undertaken by the CLV which has been pre-loaded with the subsea cable lengths stored on cable carousels. The cables are installed between the turbines and between the turbines and OSPs to form the 'strings' of turbines. The installation methodology from OSP to turbine is very similar to that of the turbine to turbine.
144. Prior to cable pull-in, dedicated preparation teams will be deployed to rig the turbine jackets and/or OSP jackets with all the required pull-in equipment and material. Preparation teams will be transferred using the walk to work vessel and/or by Crew Transfer Vessel (CTV). Sets of pull-in equipment will be available to allow the preparation teams to prepare sufficient pull-in locations simultaneously.
145. The following steps describe the key stages in the first end cable pull-in process:
  - The pull-in hoisting equipment will be lifted onto and set up on the turbine or OSP foundation.
  - The assembled Cable Protection System (CPS) will be arranged on the deck of the CLV and the sealed end of the cable will be pulled from the carousel and through the CPS on the back deck of the CLV.
  - The messenger wire is pre-installed in the foundation J Tubes prior to load out. It will be recovered from the foundation J-tube to the CLV by means of an ROV. It will then be connected to the front of the cable on the CLV.
  - The cable will then be pulled off the CLV and into the J tube by the messenger wire. This will be controlled by a team on the foundation controller a winch and a team monitoring the cable on the CLV. An ROV will also monitor entry of the cable into the J Tube.
  - The cable will be secured in the foundation by means of a hang off clamp to ensure it does not slip back down the J Tube.
146. Following 1<sup>st</sup> end pull-in of the cable the CLV will commence laying along the planned cable route towards the second WTG or OSP pull-in location.
147. Personnel will undertake preparatory work on the turbine or OSP foundation prior to arrival of the CLV as detailed prior to first end cable pull-in.
148. The CLV will stop cable laying at a pre-determined distance from the second end pull in location and cut and seal the inter-array cable. The cut and sealed end of the cable will then be routed round a cable quadrant and through the CPS.
149. The messenger wire will again be recovered onto the CLV and attached to the cable. The quadrant is then moved towards the stern of the CLV and lifted by the vessel winch located on an A-frame. The quadrant is then lowered to the seabed as the second end of the cable is pulled in through the J-tube of the turbine or OSP foundation and terminated in the same way as first end pull in operations.
150. When the quadrant reaches the seabed, the quadrant will be tripped to offload the cable.
151. Following installation testing and termination of the cables will be conducted by personnel transferred onto the jackets from the walk to work vessel or CTVs.

### 6.5.4.4 Offshore Inter-Array and Interconnector Cable Installation Stage IAC4 – Cable burial and protection

152. There may be a need for close-fitting cable protection at the cables ends between the J- or I-tubes and where the cables are buried. Rock placement or graded rock may also be required to support any free span sections of cables along these lengths. Full details of the quantity and installation methods of this protection will be confirmed in the CaP.

153. Once cables are installed on the seabed cable burial will be conducted by a hybrid trenching tool that can be set to use water jetting and/or mechanical cutting to achieve required burial depths (Figure 6-8). The trench tool can use jetting or mechanical cutting modes simultaneously to account for highly variable seabed conditions.

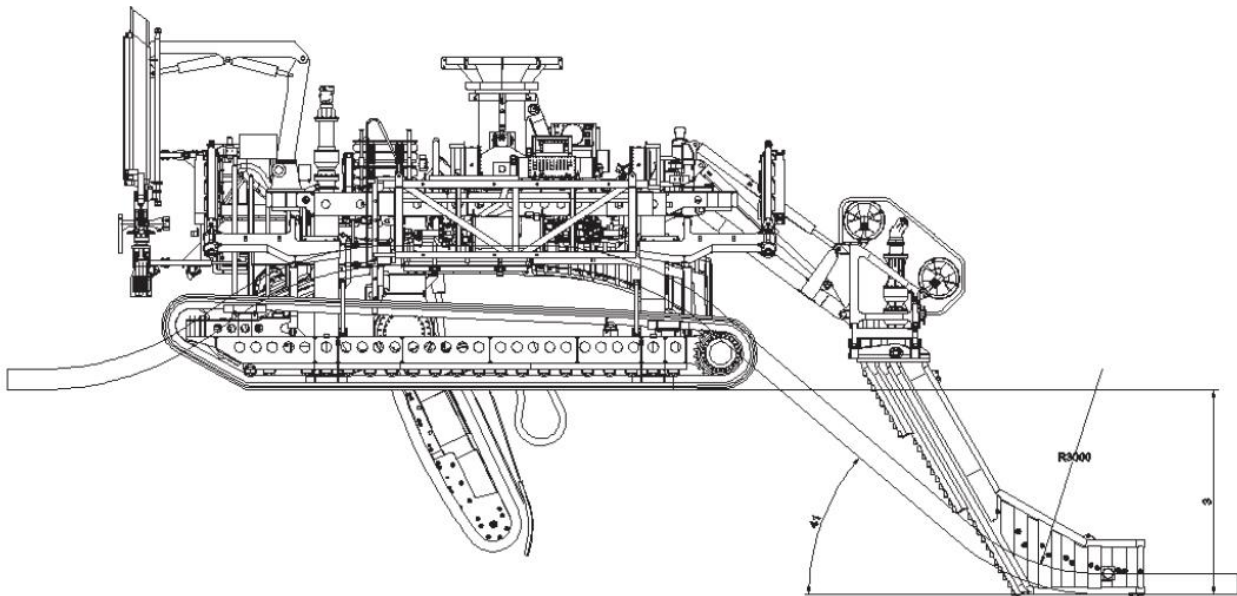

Figure 6-8: Example hybrid cable trenching tool

154. The trencher is equipped with a variety of survey and positioning equipment which are used for trencher positioning and monitoring of the cable along the route during the trenching operations. This equipment allows an assessment of depth of lowering to determine whether a second pass of the trenching tool is required. If depth of lowering is difficult to achieve using the hybrid trenching tool, then an alternative cable burial tool may be used to maximise chance of reaching the target DoL on a second pass.
155. The trencher will be deployed from the CLV and using cameras will be lowered over the surface laid cable. The trenching tool will then move along the seabed to the required starting location. The cable will then be positioned between jetting arms or loaded into a cable trough for mechanical cutting depending on the seabed conditions. The cable trenching tool will follow the path of the cable lowering the cable into the seabed using the jetting arm, cutting swords or a combination of both. If required a second pass of the trenching tool will be completed.
156. Following cable burial, a post-trench survey of the cables will be completed to determine the depth of lowering. Where the target depth of lowering has not been reached additional cable protection measures may be required. The following list details additional cable protection measures that will be considered in the event that adequate depth of lowering is not achieved:
- Durable crushed or original rock of defined size range;
  - Concrete ‘mattresses’; and
  - Bags (high strength nylon fibre) of gravel, hardened sand-cement grout, or concrete (grout / concrete pre-filled and hardened onshore). The bag option may include a technique where the grout is introduced to the nylon fibre bag offshore through proprietary pipes (the bags being permeable to water but not to grout).

## 6.6 Offshore Export Cable Installation

### 6.6.1 Components to be Installed

157. Note that the offshore export cable installation campaign has been completed, however the methodology with the remainder of Section 6.6 has not been removed, for completeness. Further detail is available in the CaP.
158. The main components that have been deposited or installed are summarised in Table 6-3.

Table 6-3: Summary of offshore Export Cable components

COMPONENT OF THE WORKS	DESCRIPTION	KEY DIMENSIONS
Horizontal Ducts	Ducts installed under landfall location	Length of ducts: 150 - 800 m
HVAC Export Cables	2 x 220 kV cable, 3-core subsea cable 630 mm <sup>2</sup>	Length of cables: ~ 37 km each, from landfall to OSP

### 6.6.2 Delivery to the Construction Site

159. All subsea cables will be transported to site direct from the point of manufacture by the Cable Lay Vessel (CLV).

### 6.6.3 Method and Process of Installation

160. An indicative export cable installation sequence is presented in Figure 6-9 below. Greater detail on each of the stages in the installation process (EC1 – EC4) is then provided in the subsequent sections.
161. It is currently anticipated that export cable installation will be completed by a CLV. A second vessel will be used to complete the burial of the cable once it has been laid on the seabed by the CLV.
162. Further detail on the cable installation process is provided in the approved CaP.

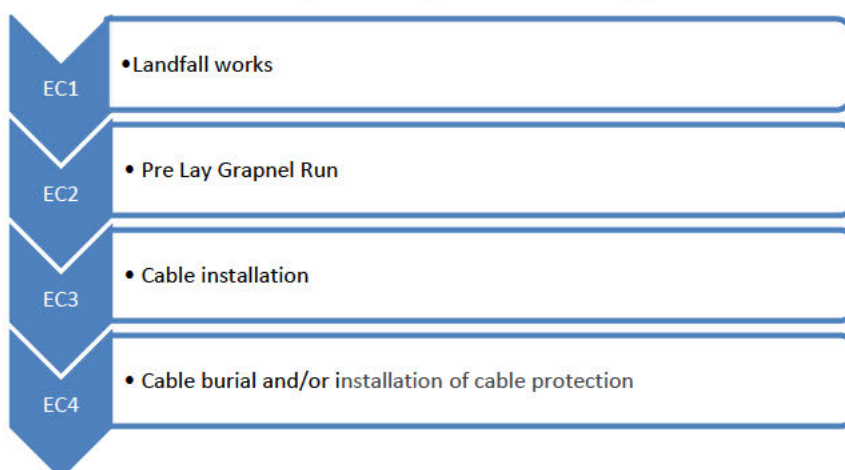

Figure 6-9: Export Cable installation sequence

#### 6.6.3.1 Export Cable Installation Stage EC1 – Landfall works

163. Ducts through which the export cables will be pulled will be installed using a HDD technique to install the cable underneath Thorntonloch beach.



164. HDD involves drilling a bore underground between two points, into which ducting for electrical cable can be installed. To achieve this, an onshore drill rig will commence drilling at the onshore end of the underground channel, above Mean High Water Spring (MHWS) landward of the sand dune system at Thorntonloch.
165. The HDD drilling process will comprise the following stages:
- A small diameter pilot hole will be drilled from the onshore drill site, for the purpose of defining the path of the channel into which the ducts and later the cable is to be installed;
  - The pilot hole will be enlarged using a steel reamer to accommodate a duct larger than the diameter of the export cable;
  - The ducting will be floated offshore and then attached to the reamer and pulled through the channel from the seaward entry point to the onshore drill site, at which point it will be sealed and protected in preparation for cable pull in at a later date. Alternatively, NnGOWL may opt to push the horizontal ducts from the entry pit on the landward site to the exit pit below MHWS. This latter option would require less nearshore vessel support and would aim to mitigate any delays that could result from weather downtime during the installation campaign.
166. The final landfall installation process will be subject to review following further surveys of ground conditions. Open cut trenching may be used at the landfall locations if ground conditions prove not to be conducive to HDD techniques.
167. In the event that HDD is not possible, excavators will be used to dig the necessary trenches. Seawards of Mean Low Water Spring (MLWS) excavators will be mounted on a barge to excavate trenches for cable duct installation. Should the sediment depth be insufficient, rock breakers or other mechanical cutting methods may be required to achieve the required burial depth. Cable ducts would be installed in the trenches and backfilled with cable pull-in operations being conducted in the same manner under both circumstances.
168. The length of the ducting is subject to further engineering analysis following survey. It is expected that the ducting, from onshore entry above MHWS to offshore exit below MHWS, will be between 150m and 800m long.
169. The final intertidal cable installation techniques are detailed within the CaP.

#### 6.6.3.2 Export Cable Installation Stage EC2 – Pre-Lay Grapnel Run

170. Seabed debris such as fishing gear and abandoned wires or chains can be detrimental to cable lay and cable burial operations and there is a risk that the seabed jetting / burial that will be used to bury cables could become entangled or stuck. Therefore, prior to the start of cable laying operations, all cable routes will be cleared of any surface debris by PLGR.
171. A specialised vessel will be mobilised together with any required survey and positioning equipment, and a grapnel assembly. Alternatively, the installation vessel may carry out the PLGR prior to installation. A variety of grapnel types are available, and suitable grapnels (which will accommodate changing sediment conditions along the cable routes) will be selected prior to PLGR.
172. The PLGR vessel will tow a seabed deployed grapnel rig along the centreline of the cable route (re-runs will be conducted where the grapnel has not stayed within the target corridor). One pass of the PLGR will be undertaken along each of the offshore cable routes. Any debris encountered will be recovered to the deck of the vessel for appropriate licensed disposal ashore.

6.6.3.3 Export Cable Installation Stage EC3 – Cable installation

- 173. Cable installation will commence at the landfall commencing with cable pull in through the installed ducts. A messenger wire will be passed through the pre-installed ducts attached to a cleaning mandrill. A dive team will then recover the messenger wire to the Dive Support Vessel (DSV) and haul the clean mandrill through the ducts. The cleaning mandrill will then be replaced with a proving mandrill that will be hauled back through the ducts to the onshore site.
- 174. The DSV will then pass the messenger wire to the CLV waiting offshore. The cable head will be attached to the messenger wire which will be hauled back through the pre-installed ducts as the CLV is paid out from the CLV (Figure 6-10).

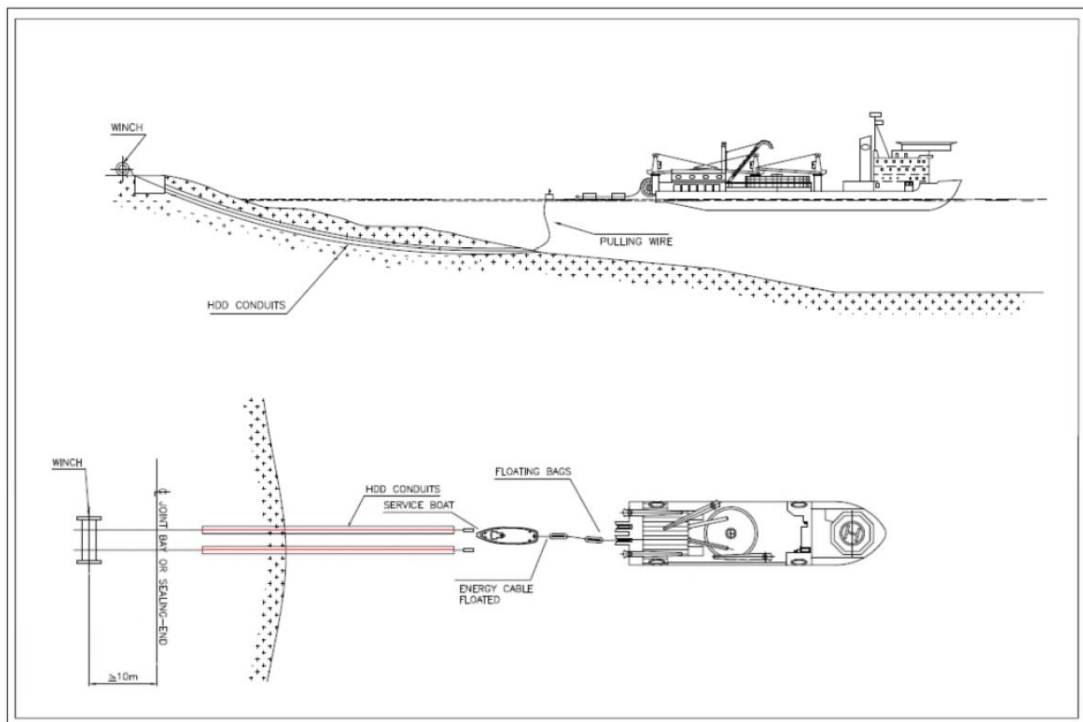

Figure 6-10: Illustration of landfall cable pull-in operations

- 175. A pull-in winch located onshore will draw the cable through the ducts installed earlier via HDD. Once the cable has been pulled into the ducts and secured onshore, the installation vessel will progress along the route laying the cable on the seabed.
- 176. Once at the OSP the CLV will stop approximately 100 m from the platform. The export cable will be cut and sealed at the appropriate length and routed around a quadrant and through the CPS for second end pull-in operations. A ROV will recover a messenger wire that is pre-installed inside the j-tubes during OSP foundation fabrication. The cable pull-in operations, managed from the OSP, will then follow the same procedures as detailed under Section 6.5.4.3 in relation to the inter-array cable pull-in.

6.6.3.4 Export Cable Installation Stage EC4 – Cable burial and protection

- 177. Following installation, the surface laid cable will be buried into the seabed where possible. Two tools are being considered to achieve the required depth of lowering for protection by burial. A jetting tool for use in softer ground conditions and a mechanical cutting tool for use in hard ground conditions, will be used to bury the cable to the target depth. The burial tool will be deployed for a second support vessel.

178. Where the target depth of lowering cannot be achieved alternative protection methods will be considered. The following materials will be considered for cable protection:

- Durable crushed or original rock of defined size range;
- Concrete ‘mattresses’; and
- Bags (high strength nylon fibre) of gravel, hardened sand-cement grout, or concrete (grout / concrete pre-filled and hardened onshore). The bag option may include a technique where the grout is introduced to the nylon fibre bag offshore through proprietary pipes (the bags being permeable to water but not to grout).

179. The final choice of protection material and the location of cable protection will be confirmed in the CaP.

## 6.7 Offshore Substation Platforms

### 6.7.1 Components to be Installed

180. The main components will be deposited or installed are summarised in Table 6-4.

*Table 6-4: Summary of Offshore Substation Platform topsides to be deposited or installed.*

COMPONENT	DESCRIPTION	KEY DIMENSIONS
<b>Offshore substation platforms</b>	Two OSPs comprising: Two jacket substructures; and Two OSP topside modules	Jacket substructures - see Section 6.4. OSP topsides: 35 m x 24 m x 15 m

### 6.7.2 Delivery to the Construction Site

181. The OSP topsides will be delivered to the Wind Farm Area on a cargo barge direct from the point of fabrication.

### 6.7.3 Method and Process of Installation

182. The OSP installation sequence is presented in Figure 6-11 below. Greater detail on each of the stages in the installation process (OSP1 – OSP5) is then provided in the subsequent sections.

183. Installation of the OSP topsides will be by the SSCV similar to the vessel used for installing the piles and jackets or by another Heavy Lift Vessel (HLV).

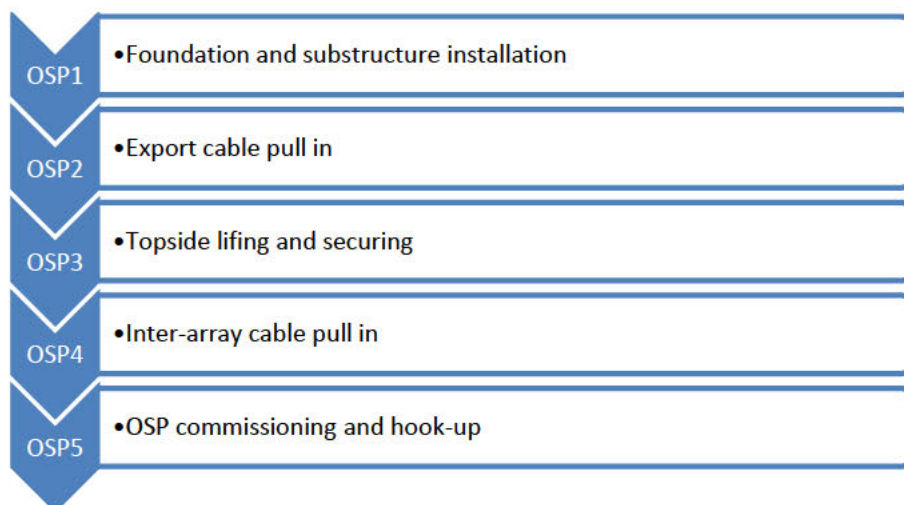

Figure 6-11: OSP installation sequence

6.7.3.1 OSP Installation Stage OSP1 – Jacket foundation installation

184. Installation of the jacket substructures for the OSPs will be as described under Section 6.3 above.

6.7.3.2 OSP Installation Stage OSP2 – Export cable installation

185. Installation of the export cable at the OSPs is detailed in Section 6.6.3.3.

6.7.3.3 OSP Installation Stage OSP3 – Topside installation

186. The topside platform, which includes the transformer module and associated switchgear, will be assembled as a single unit prior to lifting onto a barge and being transported to the Wind Farm Area. This will ensure that once offshore, the lift of the module onto the jacket substructure will take minimal time. Where possible, all rigging for lifting operations will be in place prior to shipping the module offshore.

187. The OSP topside will be lifted from the barge using the SSCV or HLV and lowered onto the jacket substructure. The topside module will be secured into position by use of a grouted, bolted or welded connection.

6.7.3.4 OSP Installation Stage OSP4 – Inter-array cable pull in

188. Once the OSP topside is secured to the jacket, the export cables will be routed to the HV switchgear and terminated. Depending on supply timings there is an option to pull in the Export Cables prior to topside installation. Inter-array cables will be pulled in to the OSP J-tubes as described in Section 6.5.4.3.

6.7.3.5 OSP Installation Stage OSP5 – OSP commissioning and hook-up

189. Once the export cables and inter-array cables are terminated the OSPs will be energised from the grid to commission the communication systems with the shore, lighting and fire-fighting system. Once all ancillary systems are enabled, the OSP HV electrical systems are commissioned. When complete the OSP is operational and able to provide energisation for the wind turbines as required.

6.8 Wind Turbine Generator Installation

190. Turbine installation will follow on from the installation of the piled foundations and jacket installation and will, take place after the installation of the associated inter-array and export cables.

### 6.8.1 Components to be Installed

191. The main components will be deposited or installed are summarised in Table 6-5.

Table 6-5: Summary of wind turbine components to be deposited or installed.

COMPONENT	NUMBER	KEY DIMENSIONS
Wind turbine tower sections	54 wind turbine towers	Hub height: 119 – 125 m Tower diameter – Base: 6 m Tower diameter - Top (below turbine): 4.1 m
Wind turbine nacelles (housing the generator etc)	54 turbine nacelles	Size: 20 m(l) x 10.5 m(h) x 8 m(w) (including hub)
Wind turbine blades	Up to 84 x 3 rotor blades	Blade length: 81.4 m Blade width: 5.45 m

### 6.8.2 Delivery to the Construction Site

192. Wind turbine components will be delivered by cargo barge from the port of fabrication to a pre-assembly lay down facility close to the Wind Farm Area. Fabrication work will be completed at various fabrication ports. Pre-assembly of the tower sections will take place prior to load out for installation. Delivery to the Wind Farm Area will be completed by the installation vessel. It is anticipated that four turbines will be transported to site at a time. This will be dependent on the final installation vessel.

### 6.8.3 Method and Process of Installation

193. An indicative wind turbine installation sequence is presented in Figure 6-12 below. Greater detail on each of the stages in the installation process (WTG1 - 6) is then provided in the subsequent sections.
194. Installation of the turbine components onto the jacket substructure will be completed by a Jack Up Vessel (JUV).

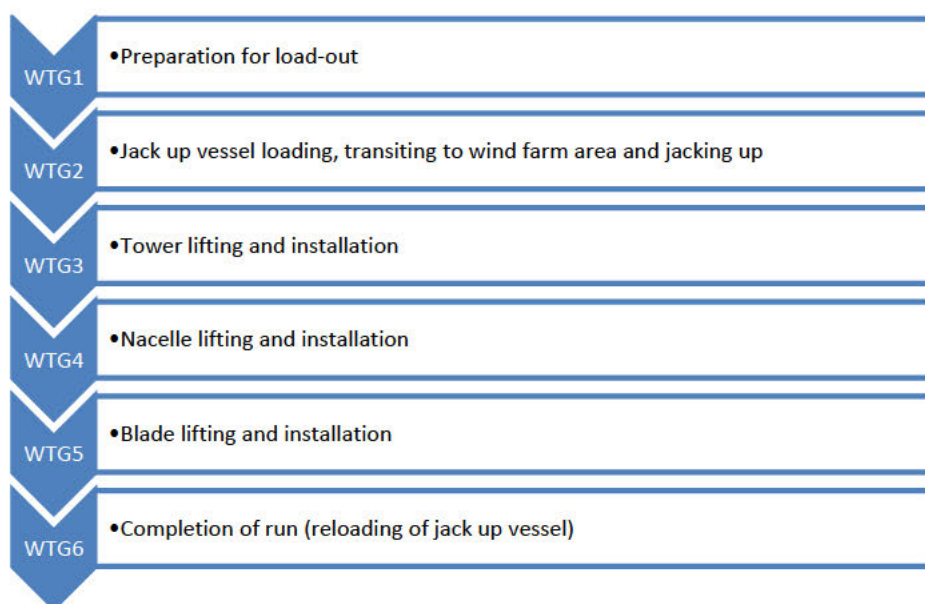

*Figure 6-12: Wind turbine installation sequence*

195. Prior to the wind turbine installation process commencing, the transition pieces of the jacket foundation structures will be surveyed, checked and cleaned ready to accept the tower sections.
196. At the lay-down construction port, the wind turbine components are readied for loading and installation. This may include pre-assembly of tower sections into complete towers. All other components will be prepared and readied for transport. Where required installation of suitable weather protection, temporary fixing of assemblies, covering of hoses, cable ends and fibre optic-cables will be completed. All bolts, washers, nuts, specialist installation tools, bolt tensioning equipment necessary to complete the wind turbine installation will be prepared and checked.

#### 6.8.3.1 Turbine Installation Stage WTG2 – Jack-up loading and transit

197. The wind turbine installation JUV will be jacked up at the quayside of the construction port and readied for loading. The turbine components are then loaded onto the jack-up vessel and fastened ready for sea transport. Multiple complete wind turbines will be loaded at a time.
198. Once the wind turbines components are loaded, the JUV prepares for sea transportation and then jacks down and sails to site, to be positioned at the first wind turbine location, adjacent to the pre-installed jacket foundation.

#### 6.8.3.2 Turbine Installation Stage WTG3 – Tower lifting and installation

199. Once the JUV is positioned adjacent to the jacket foundation, the jack-up lowers its legs (each equipped with spud cans, which are inverted cones mounted at the base of the jack-up that provide stability) to the seabed. The vessel then jacks up until the hull of the vessel achieves an adequate air gap between sea level.
200. The JUV then prepares to lift the turbine tower (the tower having been pre-assembled at the construction port). The lifting and installation process then proceeds as follows:
  - The temporary transition piece cover is removed;
  - The rigging is prepared for the tower lift;
  - The lifting gear is attached to the tower;
  - Tag lines are attached to the tower base;
  - The sea fastening bolts are dismantled;
  - The wind turbine tower is lifted and guided into position on the foundation transition piece;
  - The correct tower position is confirmed, and the connecting bolts are secured using torque and impact wrenches; and
  - The lifting gear is disconnected from the tower with the top cover and recovered to the installation vessel.

#### 6.8.3.3 Turbine Installation Stage WTG4 – Nacelle lifting and installation

201. Having completed the tower installation, the JUV then prepares to lift the wind turbine nacelle. The nacelle is the main body of the wind turbine generator and houses the main generating plant and control systems.
202. The nacelle is then lifted on to the top of the tower section as follows:
  - The nacelle is released from the transport frame;

- The rigging is prepared for the nacelle lift;
- The lifting gear is attached to the nacelle;
- Tag lines are attached to the nacelle;
- The bolts are removed at the transport frame;
- The nacelle is lifted from the deck of the vessel and guided into position on the top of the tower;
- The correct nacelle position is confirmed, and the connecting bolts are secured using torque and impact wrenches; and
- The lifting gear is disconnected from the nacelle and recovered to the installation vessel.

#### 6.8.3.4 Turbine Installation WTG5 – Blade lifting and installation

203. The JUV then prepares to lift the wind turbine blades.

204. The blades are lifted one at a time into position on the nacelle as follows:

- The blade lifting yoke is prepared;
- Tag lines are attached to the yoke;
- Confirmation is sought that the personnel in the nacelle are ready for blade lifting and attachment;
- The lifting yoke is attached to the blade and the frame / sea fastenings are released;
- The blade is lifted into position and secured on the nacelle rotor hub and secured with bolts;
- The blade is released from the lifting yoke; and
- The lift rigging & slings (and blade yoke) are recovered back to the installation vessel.

205. The nacelle is then rotated using the pre-installed power pack and the second and third blades are then lifted in turn and attached to the nacelle following the preceding sequence. When complete, the pre-installed hydraulic blade turning gear is removed. Once the blades are installed, the final turbine installation works are completed including:

- Installation of all electrical equipment in transition piece;
- Connection of turbine to the electrical equipment and commissioning within the turbine transition piece; and,
- Mechanical completion of all mechanical systems in the turbine structure.

#### 6.8.3.5 Turbine Installation Stage WTG6 – Completion of Run

206. After completion of wind turbine installation, the jack up hull is jacked down to sea level and the legs jacked up, releasing the spudcans from the seabed (it may be necessary to use water jets to release the spudcans from the seabed). The jack up vessel will then move to the next jacket foundation to repeat the preceding wind turbine installation sequence (stages WTG 3 to 5).

207. Once all of the wind turbines on board have been installed, the jack-up will be prepared for the return to port (stowing equipment etc.) and return to the construction laydown port to load the next set of turbines. Prior to energisation, some WTGs are expected to experience a period of standstill. Precautionary measures are detailed in Section 6.4.3.7.

## 6.9 Wind Farm Electrical Connection and Commissioning

208. Once the export cables and OSPs have been energised from the national grid connection at the substation at Crystal Rig Wind Farm in East Lothian, the process of offshore commissioning commences. Commissioning of the wind turbines will be carried out on an individual basis, but require initial energisation for the commissioning process, prior to generation. Therefore, the OfTW will be commissioned and energised first, allowing the Wind Farm to be commissioned and brought into commercial operation.
209. Commissioning and energisation of electrical infrastructure will involve the following principle activities, each of which is described further below:
- Energisation of the onshore infrastructure associated with the Project;
  - Energisation of each of the offshore export cables;
  - Commissioning of the OSPs;
  - Commissioning of the inter-array cable network; and
  - Commissioning of the turbines.
210. As the OfTW and Wind Farm utilise equipment operating at voltages up to 220kV, electrical infrastructure commissioning will be undertaken in accordance with high voltage safety rules that will be put in place by NnGOWL in line with industry practice.
211. It is anticipated that a JUV will be set up adjacent to the OSPs to undertake commissioning works. Personnel will transfer from the JUV to undertake the commissioning works described in this section. Alternative approaches may also be considered such as transferring personnel from a local base port or an offshore accommodation vessel daily.

### 6.9.1 Onshore Infrastructure Energisation

212. Before the OfTW and Wind Farm can be commissioned, the onshore infrastructure associated with the Project first requires to be connected to and energised from the local onshore transmission network at the connection point at Crystal Rig Wind Farm in East Lothian. This will be completed once the onshore substation extension forming part of the transmission infrastructure has been constructed.
213. The energisation process will be coordinated with National Grid and Scottish Power Energy Networks (SPEN) and, once undertaken, will allow all primary and auxiliary systems at the onshore substation to be commissioned such that they are ready to accommodate connection of the OfTW and the Wind Farm.

### 6.9.2 Offshore Export Cable Energisation

214. The first element of the OfTW that will be energised will be the offshore export cables. Each of these will be energised sequentially, together with the associated onshore export cable circuits, once onshore substation commissioning has been completed as described above.

### 6.9.3 OSP Commissioning

Once the associated export cable has been energised, power will be available to each OSP which will allow the following commissioning activities to be undertaken:

- Energisation and commissioning of the primary systems on each OSP, such as high voltage switchgear and grid transformers;



- Energisation and commissioning auxiliary systems on each OSP, such as control and communications equipment required to ensure the OSPs can be operated and monitored remotely; and
- Commissioning and testing of metering equipment.

215. Once OSP commissioning has been successfully completed, NnGOWL will be able to energise and commission the inter-array cable network.

#### 6.9.4 Inter-Array Cable Network Commissioning

216. The inter-array cable network that connects the turbines to the OSPs will be arranged in a number of circuits or 'strings'. These will be energised and commissioned individually once the cable installation and testing works described in Section 6.9.2 have been completed for each circuit. The main activities involved in inter-array cable network commissioning are as follows:

- Inspection of high voltage equipment and cable terminations along the cable circuit to ensure it is ready to be energised;
- Functional testing of the high voltage switchgear at each turbine location to ensure it is operating correctly;
- Completion of a 'switching programme' where each cable and switchgear unit on the circuit is energised; and
- Inspection and monitoring of the energised equipment prior to progressing to the next stage of Wind Farm commissioning.

217. Once each inter-array cable circuit has been energised, NnGOWL will be able to progress with energisation of individual turbines.

#### 6.9.5 Turbine Commissioning

218. Once the inter-array cable network is energised turbine commissioning activities will commence with each turbine being commissioned individually. The commissioning process will follow the Turbine Contractor's commissioning manual.

219. The energisation of the turbine is a joint activity between NnGOWL and the Turbine Contractor to ensure that the energisation is conducted safely and as efficiently as possible. WTG commissioning is completed once all WTGs have successfully undergone 240 hrs of trial run testing and the WTG SCADA system is tested and fully operational.

## 7 Good Working Practices

### 7.1 Introduction

220. The Section 36 consent and OfTW Marine Licence relating to this CoP and CMS (see Table 1-1) includes the following requirement:

*The CMS must set out the construction procedures and good working practices for installing the [Wind Farm].*

221. Good working practice is not defined by the Offshore Consents. For the purposes of complying with this requirement NnGOWL have taken the requirement to imply the following:

*The reasonable application of methods of working that have been shown to achieve the best outcomes or that reach or exceed relevant legislative standards.*

222. In the context of the construction of the Project this has been taken to apply to those standards, guidance or examples of good practice working that will act to:

- Manage the construction process so as to avoid harm to construction personnel or third parties; and,
- Ensure effects on the environment and other users of the marine environment are minimised as far as reasonably practicable (and in line with the commitments made by NnGOWL or the requirements of the project consents).

223. The following sections set out the areas of good working practices that will be applied during the construction process described by this CoP and CMS. They address the following specific areas:

- Offshore renewable industry good practice guidance;
- Health and safety procedures;
- Construction management procedures;
- Environmental management procedures; and
- Specific good working in relation to aspects of the construction process (as set out in Section 7.5 of this CoP and CMS) (that, for example, act to avoid or reduce environmental impacts or impacts on other users).

224. Cross reference is made to other relevant consent plans (as described under Section 1.3 of this CoP and CMS).

### 7.2 Offshore renewable industry good working guidance

225. There are a number of good practice guidance documents that have been produced for or in relation to the offshore renewables industry in recent years. Where relevant, NnGOWL will require that such good practice is reflected in the detailed method statements produced by the Contractors.

226. Industry guidance documents are listed in Table 7-1.

Table 7-1: Offshore wind good working practice guidance

PRODUCED BY	TITLE	SCOPE
The G9 <sup>1</sup> , published through the Energy Institute	Working at height in the offshore wind industry (published November 2014)	Covering design, construction, commissioning, and operation; designed to reduce the need for work at height; topic guidance sheets, covering common hazards, personal protective equipment, training and competence, fitness requirements, and the responsibilities of those procuring, supervising and undertaking work; with supporting information, such as regulatory requirements in selected EU countries and technical standards.
	The safe management of small service vessels used in the offshore wind industry ( <u>2<sup>nd</sup> Edition</u> ) (published January 2018)	Cover working with vessels that have a gross tonnage of less than 500, such as crew transfer vessels, guard vessels, survey vessels and construction support vessels. The guidelines cover audit and inspection regimes for Wind Farm service vessels, operating procedures for routine marine operations, training and competence of crew and passengers, and safety equipment.
The Crown Estate	Sharing lessons learned and good practice in offshore transmission (published June 2014)	Presents the findings from a study commissioned to understand experience and lessons learned in the development, construction and operation of offshore transmission infrastructure.
	Construction vessel guideline for the offshore renewables industry (Published September 2014)	This guideline is designed to follow on from Vessel safety guide 'Guidance for offshore renewable energy developers (Vessel safety guide)' published by RenewableUK in January 2012 and is intended to assist by providing guidance to developers and the supply chain for the construction of an UK offshore Wind Farm project.
RenewableUK	Offshore Wind and Marine Energy Health and Safety (H&S) Guidelines (published March 2014)	H&S guidelines for the offshore wind sector covering all phases of development and identifying risks and significant safety hazards and activities.

<sup>1</sup> Formed in 2010, the G9 comprises nine of the world's largest offshore wind developers and focuses on creating and delivering world class health and safety performance across all of its activities in the offshore wind industry. Membership comprises Centrica, Statoil, Eon, RWE, DONG Energy, Scottish Power Renewables, SSE, Statkraft and Vattenfall.

PRODUCED BY	TITLE	SCOPE
	Integrated Offshore Emergency Response – Renewables (IOER-R) - Good Practice Guidelines for Offshore Renewable Energy Developments (Published 2016)	Sets out a recommended approach for managing and responding to emergencies taking account of existing and emerging industry good practice within the framework of UK health and safety legislation.
	Safety Circular: Notices to Mariners. Guidance for Offshore Wind & Marine Projects (Published 2013)	This Circular provides a short summary of the accepted scope and format for issuing Notice to Mariners (NtMs).
	FLOWW Best Practice Guidance for Offshore Renewables Developments: Recommendations for Fisheries Liaison (Published January 2014)	Sets out best practice guidance on liaison between the offshore wind industry and the fishing industry.
	Guidelines for Selection and Operation of Jack-ups in Marine Renewable Energy Industry (Published February 2013)	Industry guidance aimed at jack-up owners, operators, developers and contractors engaged in site-investigation, construction, operation and maintenance of offshore wind and marine energy installations.
	H&S First Aid Needs Assessment (Published August 2013)	Provide basic information on how duty holders can assess the provision of adequate and appropriate equipment, facilities and personnel to ensure employees receive proper attention if they are injured or taken ill at work.
	Vessel Safety Guide Guidance for Offshore Renewable Energy Developers (2015)	Provides guidance and insight on the selection of vessels through all phases of Wind Farm development.

### 7.3 Construction management procedures

227. NnGOWL will ensure a range of project management procedures are in place during the construction process that will, alongside the relevant approved consent plans, act to ensure the safe, compliant installation of the major project components as described in this CoP and CMS, including but not limited to:

- A dedicated marine coordination centre to coordinate all activities on site including all vessel and personnel movements, electrical switching and site surveillance.
- Detailed construction method statements and risk assessments prepared by each of the main Contractors;
- Appropriate interface management procedures;
- A detailed integrated construction programme maintained regularly with input from the main Contractors;

- Clear roles and responsibilities allocated to all parties (see also Section 5 above);
- Appropriate and regular communications between all contracted parties and with relevant third parties;
- Marine warranty survey at all key construction activities
- Appropriate third-party certification of the Wind Farm design; and
- A clear process of reporting, recording and auditing of the construction process, contractor performance and methods for managing shortfalls in performance.

## 7.4 Environmental management measures

228. The environmental management measures that will be applied by NnGOWL and Contractors incorporate a variety of good working practice and legislative standards in relation to the control of waste, dropped objects, pollution prevention, chemical usage, control of invasive non-native species, etc. Environmental management measures are set out in the EMP which, once approved, will be applied in undertaking the proposed construction works set out in this CoP and CMS.
229. In addition to the EMP, a number of other consent plans or requirements also incorporate matters related to environmental management (and incorporate elements of good working practice) including:
- The PS – management of foundation piling operations to mitigate effects on sensitive receptors;
  - The NSVMP – setting out matters related to the management of construction vessels to ensure navigational safety and the management of vessel operations to mitigate effects on other sea users and marine wildlife;
  - The LMP– lighting and marking to mitigate impacts on other sea users;
  - The MPCP – response to pollution incidents;
  - The CaP – cable installation procedures;
  - The commercial Fisheries Liaison Officer (FLO) – liaison with the local fishing industry and notification of planned works, vessel movements etc; and
  - The archaeological WSI and PAD.
230. In addition, any matters set out in the environmental statement in relation to the mitigation and management of construction will be incorporated into the CoP and CMS (see Section 7 below and Appendix A).

## 7.5 Project-specific good working practices

231. There are a number of specific good working practices that will be applied to certain aspects of the construction process as set out in this CoP and CMS and that will seek to minimise the environmental effects arising from the construction. The following sections set out the good working practices related to:
- Drill arisings;
  - Grouting operations;
  - Seabed preparation and jack-up usage;
  - Cable and scour protection;
  - Piling operations;

- Drilling muds;
- Cable installation; and
- Minimising effects on other sea users.

232. A number of these are also set out in relation to environmental management in the EMP.

#### 7.5.1 Drill arisings

233. Volumes of drill arisings from pile installation will be minimised by undertaking a detailed analysis of ground conditions to minimise socket depth as far as practicable.
234. The material will be released at the drill head and will settle onto the seabed. The drill arisings will be dispersed by prevailing hydrodynamic forces.

#### 7.5.2 Grouting

235. Grout will be used to cement the piles into the seabed and to connect the piles to the jacket structures. The volumes of grout required will be minimised as far as possible through design.
236. Grout loss will be minimised by the monitoring and control of grout volumes being injected into each joint and by the subsea monitoring of grouting operations by use of an ROV.
237. The high-pressure grouting equipment will be pressure tested onshore prior to being loaded onto the installation vessel to ensure there are no leaks. Once grouting is complete the grouting equipment will be cleaned on the vessel with water in a controlled manner to prevent grout from washing overboard.

#### 7.5.3 Seabed preparation and anchor / jack-up movements

238. Jack up movements and leg re-positioning will be minimised through the design of installation process so as to avoid unnecessary disturbance to seabed habitats.

#### 7.5.4 Cable and scour protection

239. The current foundation design basis is intended to avoid the use of scour protection around the jackets. It is, however anticipated that some scour protection may be required around cable J-tubes and around the OSP jackets due to the number of cables terminating into these jackets.
240. The need for cable protection material is not currently anticipated, other than localised and close-fitting cable protection at the cables ends between the J- or I-tubes and the buried sections as referenced above. There may be a requirement to install cable protection where target burial depth is not achieved.

#### 7.5.5 Piling Operations

241. Where impact driving is required during piling operations to install casings, piling mitigation will be implemented to minimise the risk to sensitive marine mammal and fish species. The piling mitigation will be agreed with MD-LOT through submission and approval of the PS.

#### 7.5.6 Drilling muds

242. Drilling operations will use water-based drilling systems. No oil based muds will be used during intertidal HDD or offshore drilling operations.

#### 7.5.7 Cable Installation

243. Where possible during cable installation (see Section 6.5.4.4 and 6.6.3.4) cable burial will be completed by the use of a water jetting trenching tool. These tools use a high-pressure water jet to fluidise the

seabed soils allowing the cable to sink under its own weight to the target burial depth. They rely on the disturbed sediment settling back into the cable trench to create cover / backfill on top of the cable as the trenching tool passes.

- 244. To maximise post-trenching cable cover and to minimise the disturbance of sediment away from the trench, site specific trencher settings will be derived based on the soil conditions to ensure disturbed sediment is monitored and managed efficiently throughout operations.
- 245. Where harder ground conditions exist a cable burial tool with mechanical cutting capabilities will be used.

### 7.5.8 Minimising effects on other sea users

- 246. NnGOWL recognise that the Project represents a major infrastructure construction project in the waters of the outer Forth and Tay area that are also used by a variety of other marine users including other commercial shipping, the commercial fishing industry and recreational sailors.
- 247. In order to ensure that effects on these other marine users are minimised, standard good working practices will be employed to ensure effective communication to minimise interactions and communicate risks arising from construction works to others in the vicinity of the construction site. A number of these are specific requirements of the consents but also represent good working practice.
- 248. As detailed in Section 1.3 the Offshore Consents conditions require a number of consent plans which must be consistent with this CoP and CMS. Table 1-2 details those linkages to the CoP and CMS and outlines relevant measures within each consent plan which will be implemented throughout construction and are considered to be good practice measures to minimise effects on other sea users.
- 249. In addition, to those consent plans that are required by the Offshore Consents conditions to be consistent with this CoP and CMS, NnGOWL will also ensure that, where relevant, the measures outlined in the following plans are consistent with the broader suite of consent plan documents:
  - Fisheries Management and Mitigation Strategy; and
  - Emergency Response and Cooperation Plan.

## 8 Compliance with the Application

### 8.1 Introduction

250. In addition to the conditions presented in Table 1-1, Condition 7 of the S36 Consent states that:

*the Development must be constructed and operated in accordance with the Application (as supplemented by the additional environmental information (“EIA Addendum”), submitted by the Company on 26 July 2018) and any other documentation lodged in support of the Application*

251. Condition 3.1.1 of both the Wind Farm and OfTW ML also state that:

*The Licensee must at all times construct, operate and maintain the Works in accordance with this licence, the Application and the plans and programmes approved by the Licensing Authority.*

252. Sections 8.3 and 8.4 set out information from the Application and supporting information with regard to:

- Compliance with the construction methods assessed; and
- Construction related mitigation and management from the Application and supporting information.

### 8.2 Compliance with the Indicative Construction Programme Assessed in the Application and Supporting Information

253. The S36 Consent and Marine Licence (OfTW) conditions (see Section 1.2) require that this CoP and CMS is in accordance with the Application and supporting information.

254. The Application and supporting information set out an indicative construction programme which identified anticipated durations for key construction activities. Figure 8-1 presents the durations of the key construction activities within the current offshore construction programme compared with the indicative dates assessed in the EIA.

Construction Activity	2021												2022												2023												2024												2025															
	A	S	O	N	D	J	F	M	A	M	J	J	A	S	O	N	D	J	F	M	A	M	J	J	A	S	O	N	D	J	F	M	A	M	J	J	A	S	O	N	D	J	F	M	A	M	J	J	A	S	O	N	D	J	F	M	A	M	J	J				
Casing and piles - Installation																																																																
Export cable - Landfall works																																																																
Jackets - Installation																																																																
Export cable - Installation																																																																
Inter-array cables - Installation																																																																
OSP topsides - Installation																																																																
Interconnector cable - Installation																																																																
Wind turbines - Installation																																																																
Final commissioning																																																																

Figure 8-1: Current offshore Construction Programme detailed within this CoP and CMS (dark blue) compared with the indicative offshore construction programme presented in the EIA Report (light blue). Hatched areas represent overlap between the two construction programmes<sup>2</sup>

255. The comparison set out in Figure 8-1 indicates that the majority of construction activities are similar in duration and time of year to the construction windows identified within the EIA Report. The exception to this is the foundation installation campaign which continues through the winter months. The key

<sup>2</sup> Interconnector cable installation was considered part of the inter-array cable installation activity within the EIA Report.



variance between the EIA anticipated programme and that presented within this CoP and CMS is the activities which are occurring in 2023 and 2024.

- 256. The inter-array cable installation campaign is shorter than those considered in the EIA Report. The pile installation, the jacket installation and wind turbine installations are greater than those considered in the indicative Application programme; this reflects potential breaks due to vessel availability built into the programme presented in this CoP and CMS and a longer pile location preparation and installation period than expected. The Export Cable and OSP topside installation campaign are the same duration as detailed in the indicative Application programme.
- 257. Whilst there is variation between the indicative programme and the programme detailed within the CoP and CMS it is not considered to change the environmental sensitivities considered within the EIA Report. On this basis it is considered that the CoP and CMS complies with the Application and supporting information.

### 8.3 Compliance with the Construction Methods Assessed in the Application and Supporting Information

- 258. The Application and supporting information described the range of methods that could be applied during the construction of the Project incorporating, where necessary, a variety of options in relation to the Project design and the approach to installation.
- 259. Since the Project consents were awarded, the design of the Project and the approach to installation has been refined to that described in this CoP and CMS (and in other relevant consent plans). In order to demonstrate compliance of this refined design, construction methods described in the Application and supporting information are summarised in the following sections below and compared to the construction methods detailed within this CoP and CMS (see Figure 8-2 to Figure 8-7).

#### 8.3.1 Turbine and OSP Pile Installation

- 260. Figure 8-2 summarises the foundation options and assumed installation methods presented within the EIA Report and Addendum. It also summarises the selected options and confirmed installation methods described in this CoP and CMS.

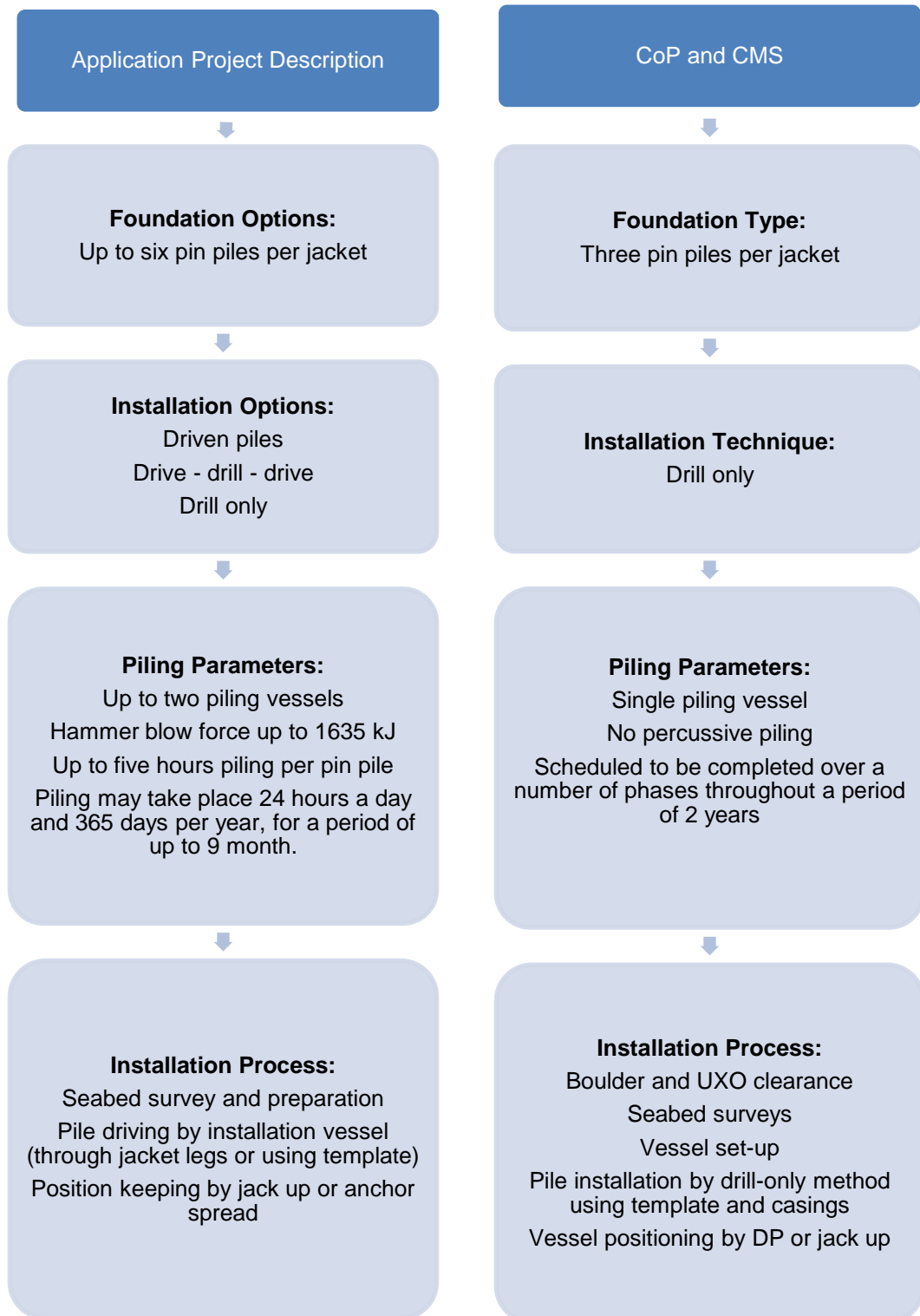

Figure 8-2: Comparison of support structures (foundation) installation methods described in the Application and the CMS

8.3.3 Turbine and OSP Jacket Installation

261. Figure 8-3 summarises the jacket substructure options and assumed installation methods presented within the EIA Report and Addendum. It also summarises the selected options and confirmed installation methods described in this CoP and CMS.

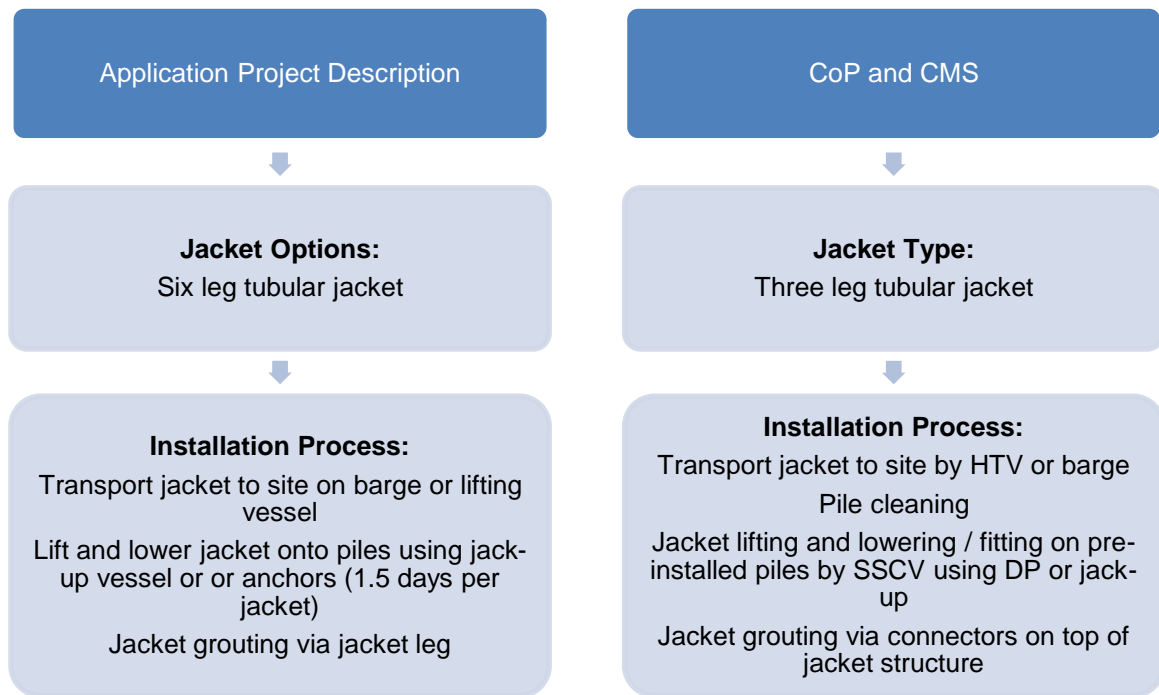

Figure 8-3: Comparison of jacket substructure installation methods described in the EIA Report and the Addendum and the CMS

8.3.4 Inter-Array Cable Installation

262. Figure 8-4 summarises the inter-array cable options and assumed installation methods presented within the EIA Report and the Addendum. It also summarises the selected options and confirmed installation methods described in this CoP and CMS.

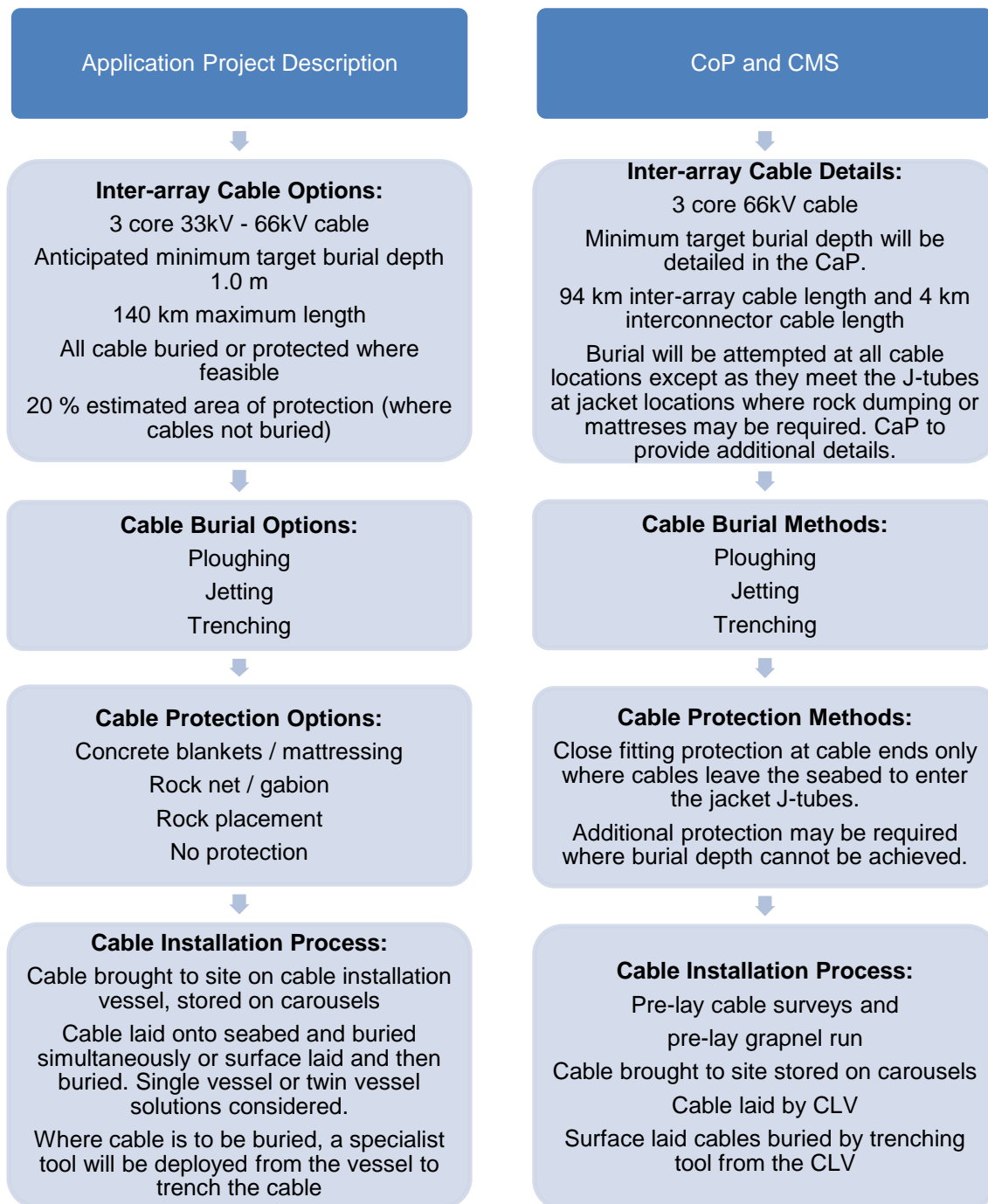

Figure 8-4: Comparison of inter-array and interconnector cable installation methods described in the EIA Report and the Addendum and the CMS

8.3.5 Wind Turbine Installation

263. Figure 8-5 summarises key turbine details and installation methods presented within the EIA Report and the Addendum. It also summarises the selected options and confirmed installation methods described in this CoP and CMS.

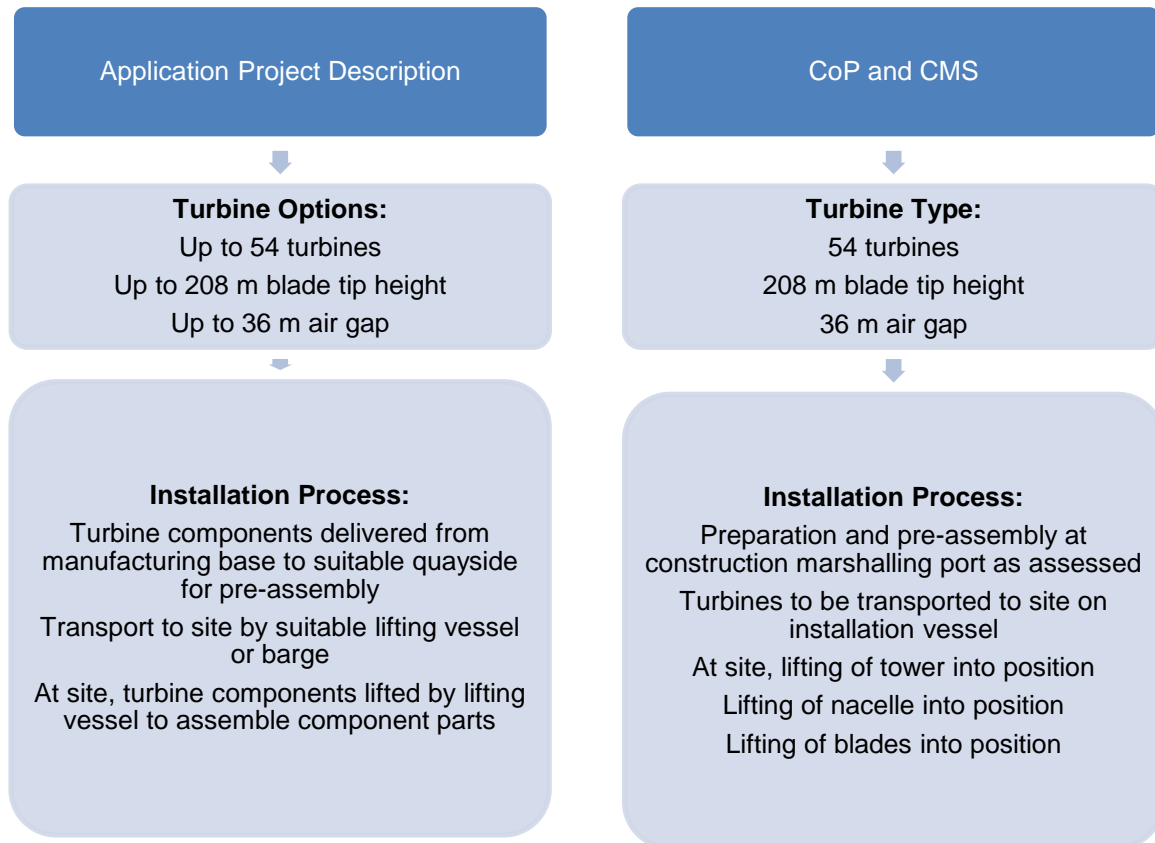

Figure 8-5: Comparison of turbine installation methods described in the EIA Report and the Addendum and the CMS

8.3.6 Offshore Substation Topside Installation

264. Figure 8-6 summarises the OSP topside options and assumed installation methods presented within the EIA Report and the Addendum. It also summarises the selected options and confirmed installation methods described in this CoP and CMS.

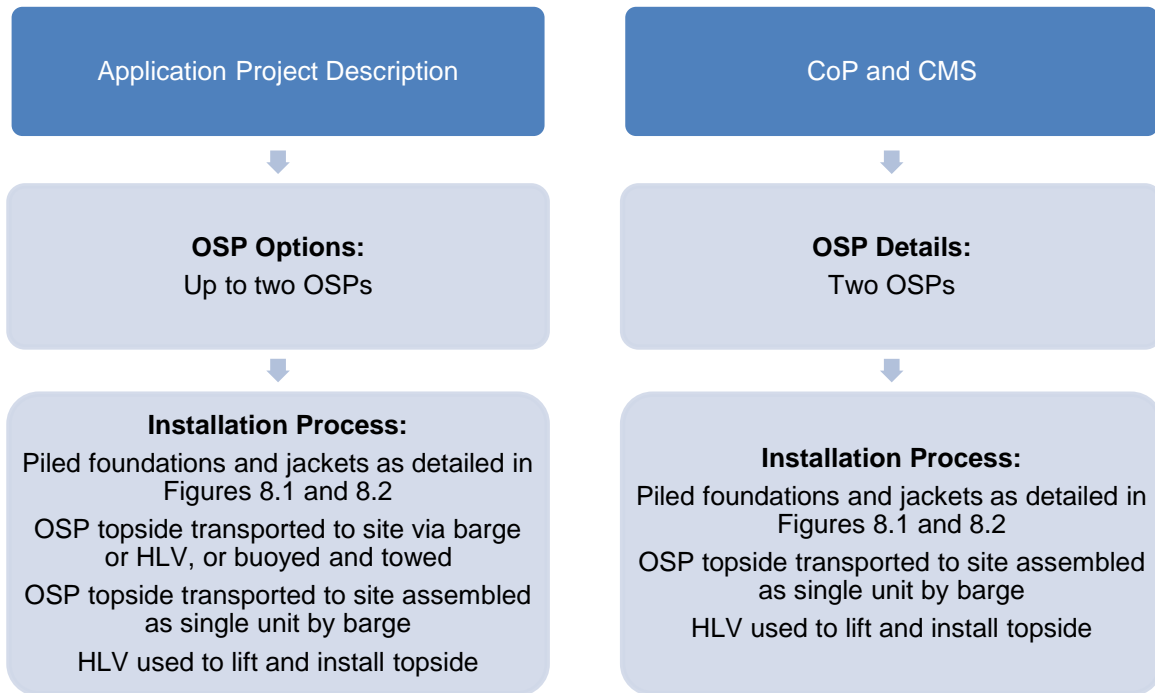

Figure 8-6: Comparison of the offshore substation topside installation described in the EIA Report and the Addendum and the CMS

8.3.7 Offshore Export Cable Installation

265. Figure 8-7 summarises the Offshore Export Cable options and assumed installation methods presented within the EIA Report and the Addendum. It also summarises the selected options and confirmed installation methods described in this CoP and CMS.

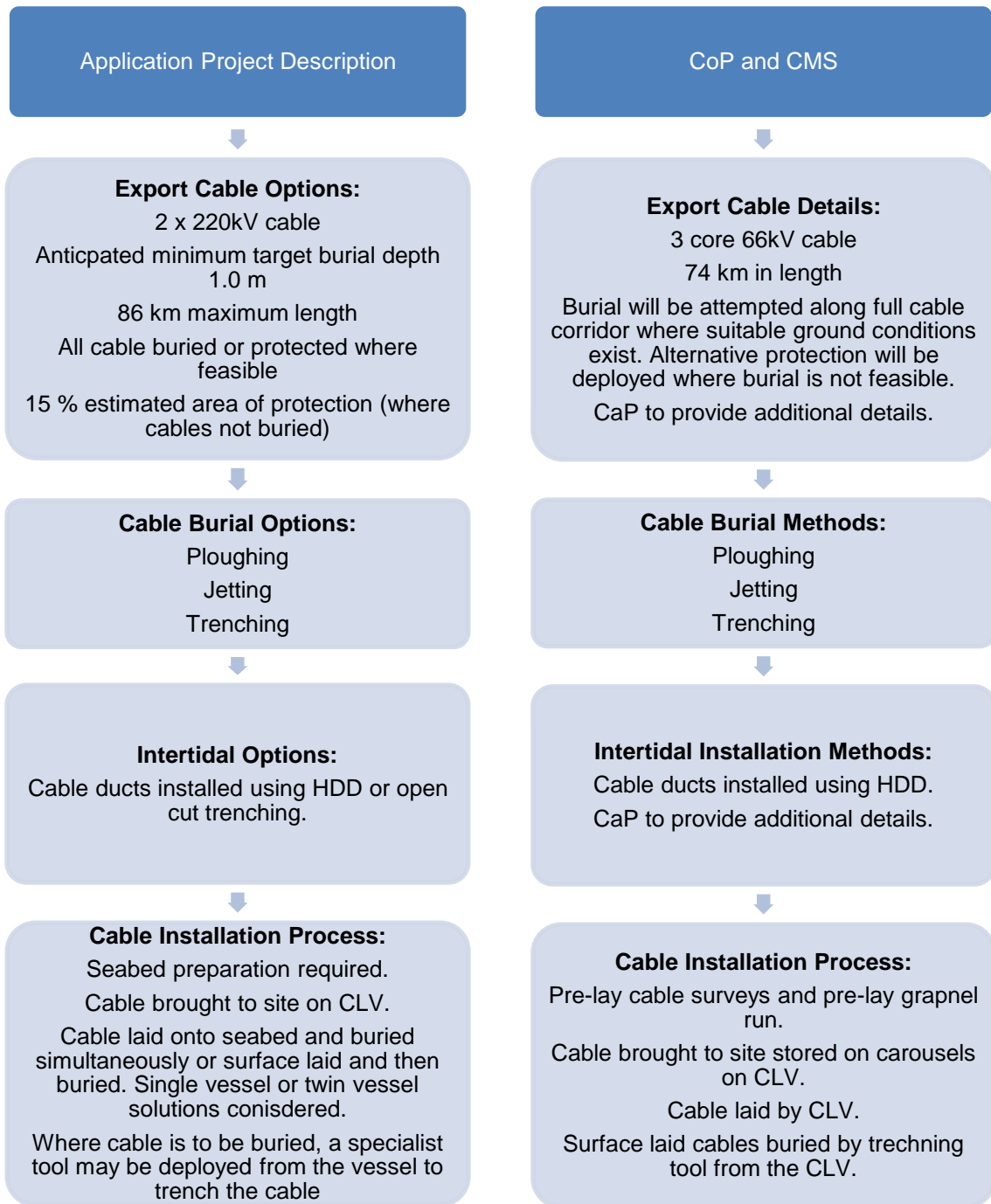

Figure 8-7: Comparison of Offshore Export Cable installation methods described in the EIA Report and the Addendum and the CMS

## 8.4 Delivery of Construction-related Mitigation Proposed in the Application and Supporting Information

266. The EIA Report and the Addendum detailed a number of mitigation commitments specific to installation activities. The construction-related mitigation measures are primarily associated with the process of installing piles and jackets. Measures are summarised in Table 8-1 and cross-referenced with where they are addressed within this CoP and CMS.
267. Other construction related mitigation measures that will be implemented will be detailed within the wider suite of consent plans as summarised in Table 1-2.

*Table 8-1: Construction related mitigation measures relevant to the CoP and CMS.*

CONSTRUCTION PROCESS	MITIGATION MEASURE	WHERE ADDRESSED
<b>Foundation and Jacket Installation</b>		
Scour protection	NnGOWL will implement scour mitigation including rock armouring, matting, and frond mats.	Section 7.5.4
Pile Installation	Pile driving will be undertaken using the lowest possible hammer energy to allow satisfactory pile installation and will implement soft starts at the beginning of pile driving operations.	Drill only approach being implemented.
<b>Cable Installation</b>		
Cable protection	Cable will be buried where possible to mitigate impacts on physical processes, benthic habitats and other sea users. Cables, where techniques allow, should be back filled to increase recovery rates.	Described in Section 6.5.4.3, 6.6.3.4 and 7.5.7.  Where ground conditions permit appropriate burial tools will be used, sediment will settle back into the cable trench.  Further details presented in the CaP
Cable Specifications	Cable specifications will be compliant with industry standards and best practice such as the relevant International Electrotechnical Commission (IEC) specifications to minimise risk of effects resulting from EMF to benthic and fish communities.	Details provided in the CaP.
<b>Site Management</b>		
Safety Zones	Construction safety zones of 500 m around major activities will be in place to exclude vessels not associated with the construction works for the Project. Guard vessels, or another nominated vessel, will be used to monitor passing traffic and contact vessels, which could infringe the safety zones. 50 m pre-commissioning safety zones may also be included. Minimum safe passing distance may be requested by vessels where safety zones are not applicable.	Details provided in the NSVMP.